



Large scale hydrogen production from renewable energy sources in Brazil

Session W5

Global Interaction and Use of Natural Resources for Hydrogen Production

Hydrogen Energy Systems: an increasingly accepted idea

- Hydrogen Energy Movement
- 21st Century – the most fruitfully time
- Renewables catalyzing the momentum
- Strengthening arguments
- Rationale for Brazil and Latin America Region

Hydrogen Energy Systems: Sustainable concept over the time From Oil Scarcity (70's - 80's) to Global Warming (90's - XXI Century)

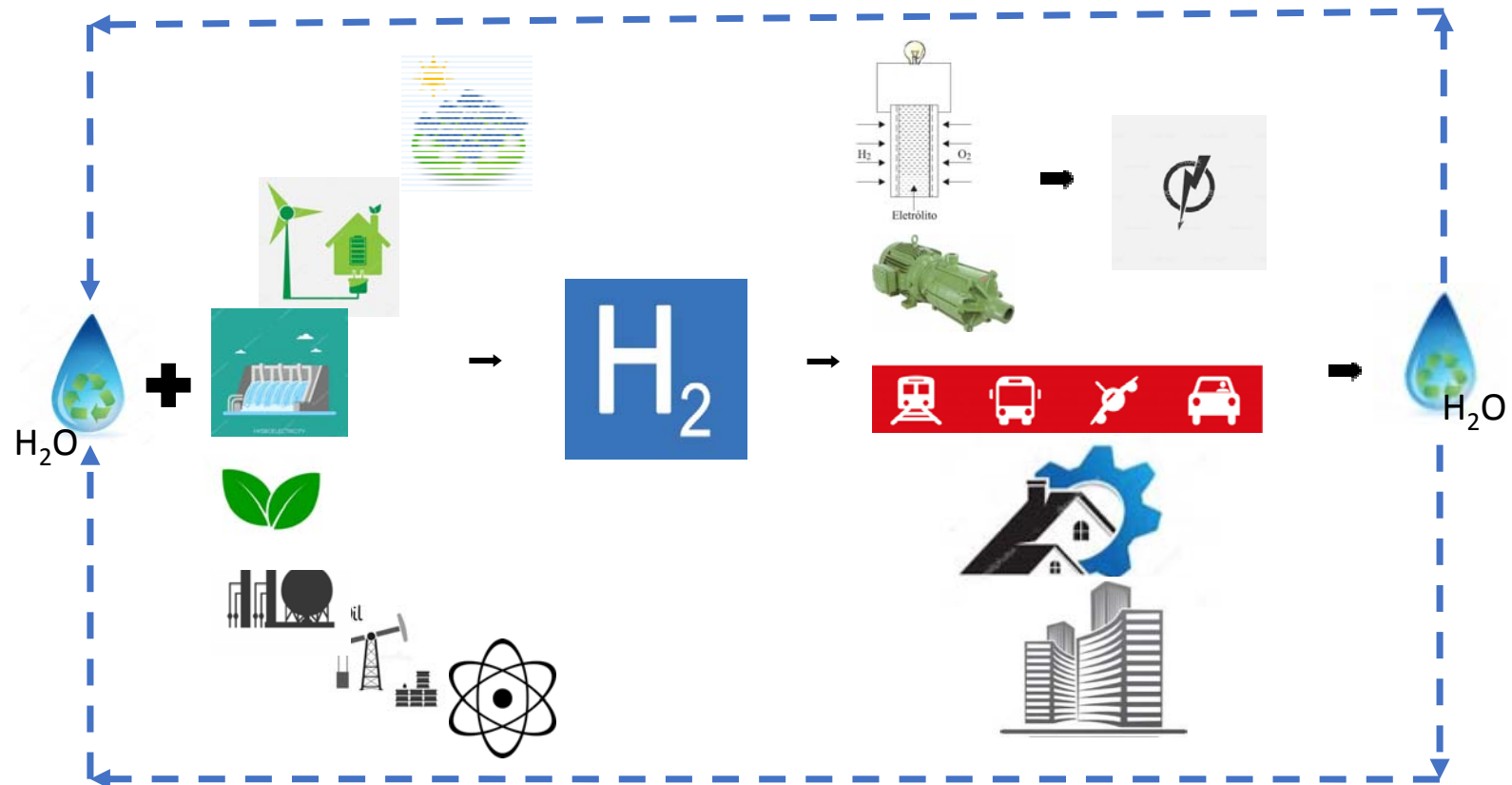

The Movement in Brazil

Middle 80's

- Fossil Fuels Substitution



- Same rationale of The Brazilian Ethanol Program, to replace fossil fuels
- Federal Government Working Group (CDH) to propose strategies to develop Hydrogen Strategy for Brazil

Middle 90's

- Fuel Cell Buses for Urban Transportation



- Under positive impact of the World Conference on Environment in Rio 1992 (ECO 92)
- Hydrogen as a clean fuel to reduce air pollution in metropolitan areas
- Support from The Global Environmental Facility (GEF)

XXI Century – The Global Warming

Expressive increase utilization of Renewables

40 GW next 8 years

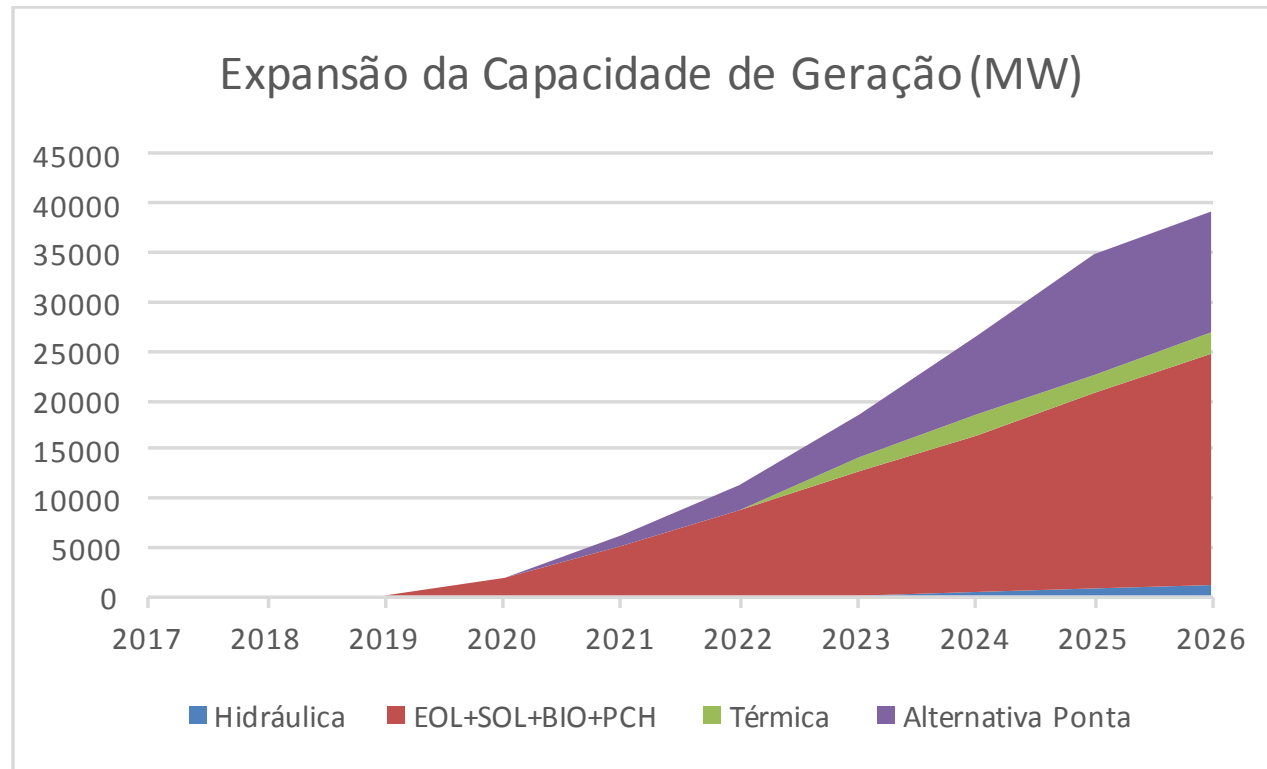

Source: EPE, PDE 2026

Impacts on Power Systems

- Real involvement of Power Industry Agents (Utilities, IPPs, System Operator, Regulator)
- Operations (intermittencies) and Economics (Cash flows)

Example: Power Generation Ramp up/Ramp down

California, USA

Over 200 MW loads re-allocation,

< 1 min

(Source: PG&G, 2014)

Brazil

Over 80 MW loads re-allocation,

< 15 min

(Source: ONS, 2015)

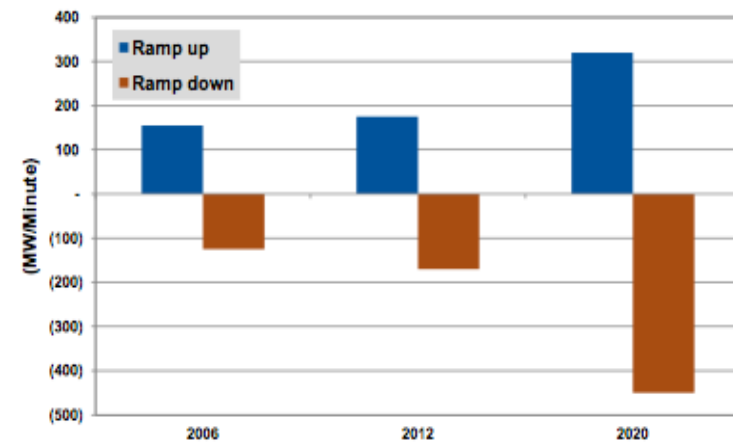

(Sources: Pacific Gas and Electric Company, California Independent System Operator)

Strengthening arguments

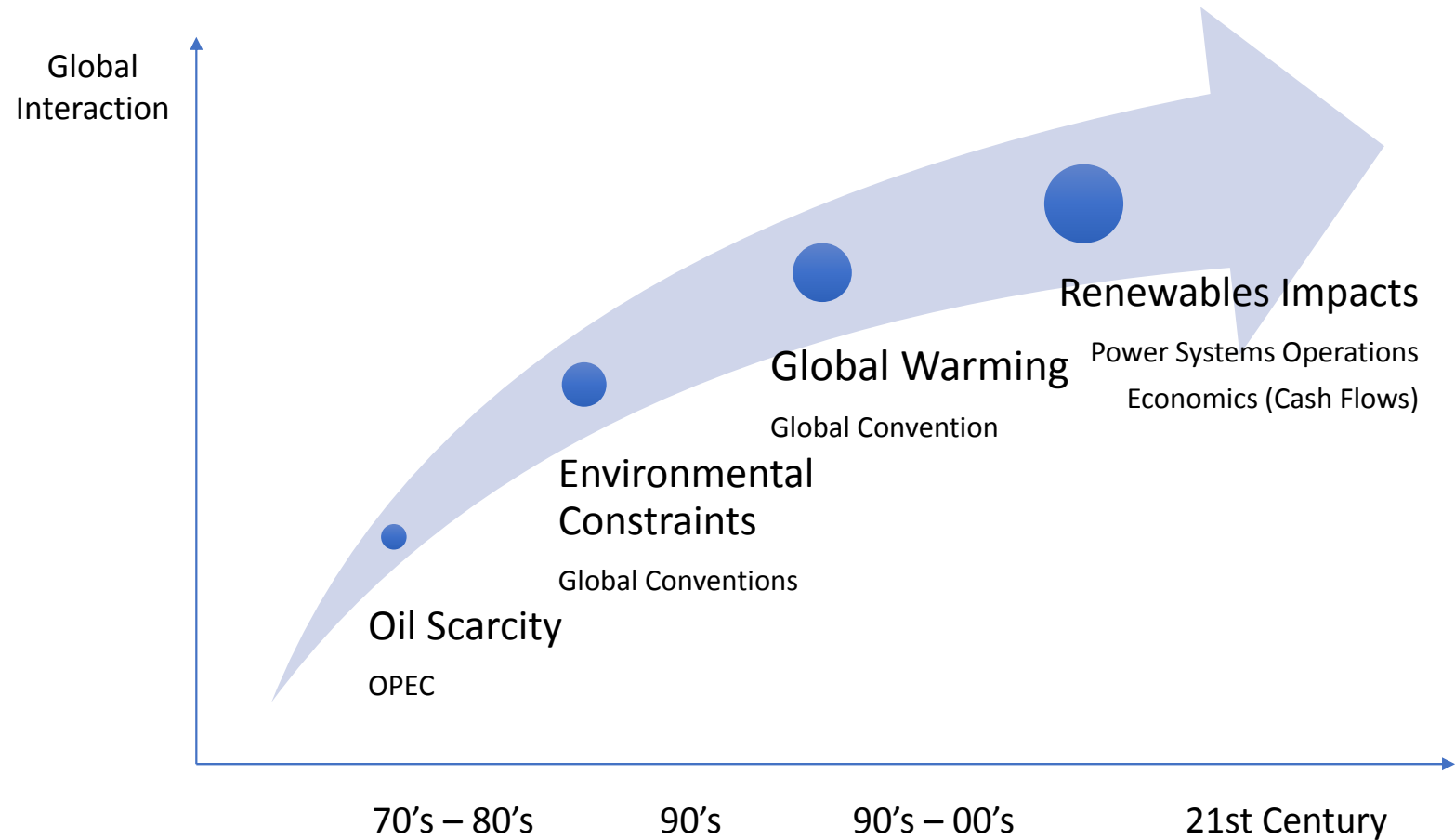

Brazil: Rationale for large scale energy storage

Hope for moving ahead towards Hydrogen Economy

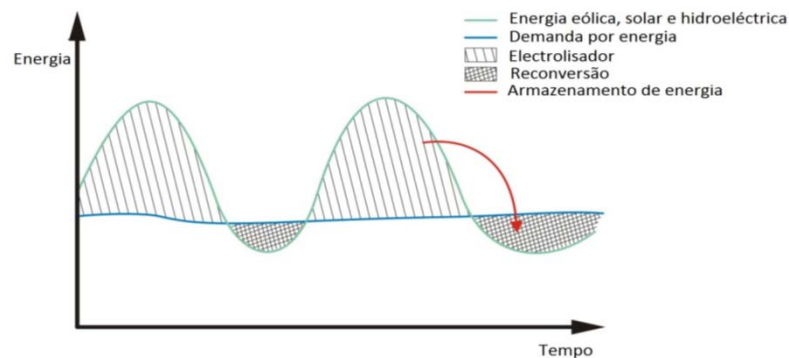

- Brazil Interconnected Power System (SIN): 12 hydro basins, 5 geoelectric systems, 142 GW installed capacity, 134,765 km transmission lines
- Historical hydro based large scale integration: 20% increase in firm energy
- Progressive reduction of energy storage capacity in hydro reservoirs as hydroelectricity generation expands through the very flat Amazon region

Public Call ANEEL #21 for R&D Projects

- Brazilian initiative to speed up innovation in energy storage
- Building Hydrogen Storage pilot plants connected to SIN
- Comparison to other technologies of energy storage
 - Operational performance
 - Potential for scaling up
 - Environmental impacts vs benefits
- Economics, technical, commercial and regulatory conditions
- Capacity building
- Technological Roadmap for Energy Storage in Brazil, requirements to local industry

Renewables large scale challenges: seasonality, intermittenencies and surplus

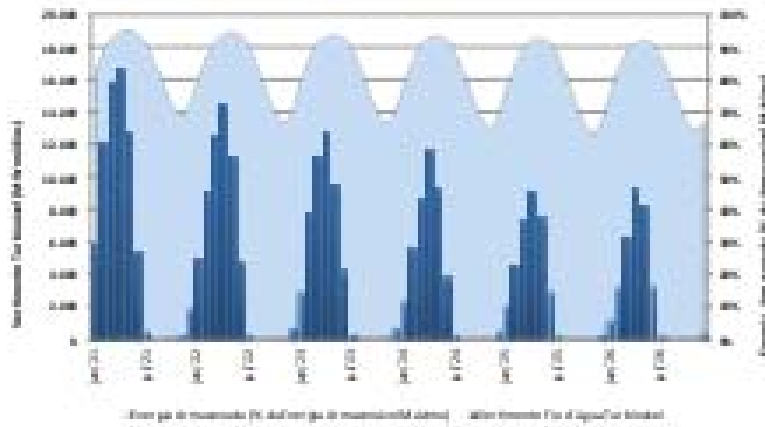

Source: EPE, PDE 2026

- Recent historical data
- Brazil North Power Generation System (Amazon Hydro Basin)
- Very flat geographical relief
- Over 12.7 GWh/year surplus hydroelectricity

- Evaluation of forecasted power generation (SIN), 2021 - 2026
- Surplus hydroelectricity
- Over 50.4 GWh/year
- January to June every year

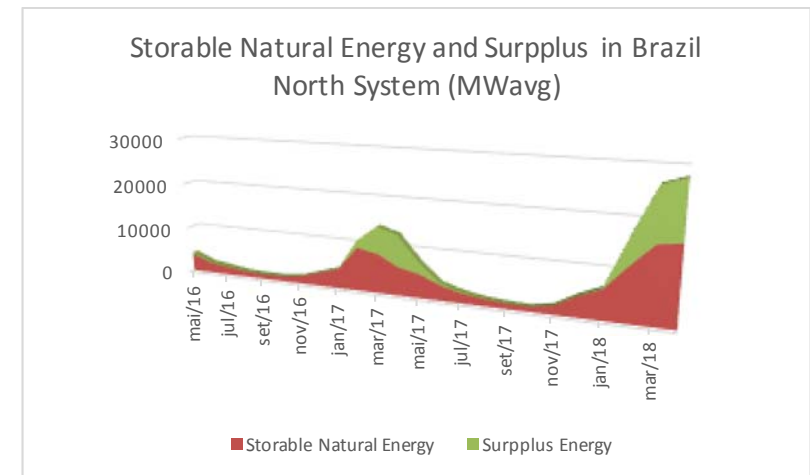

Source: ONS, 2018

Hydrogen: the only energy storage vector at large scale

Great challenge for the market

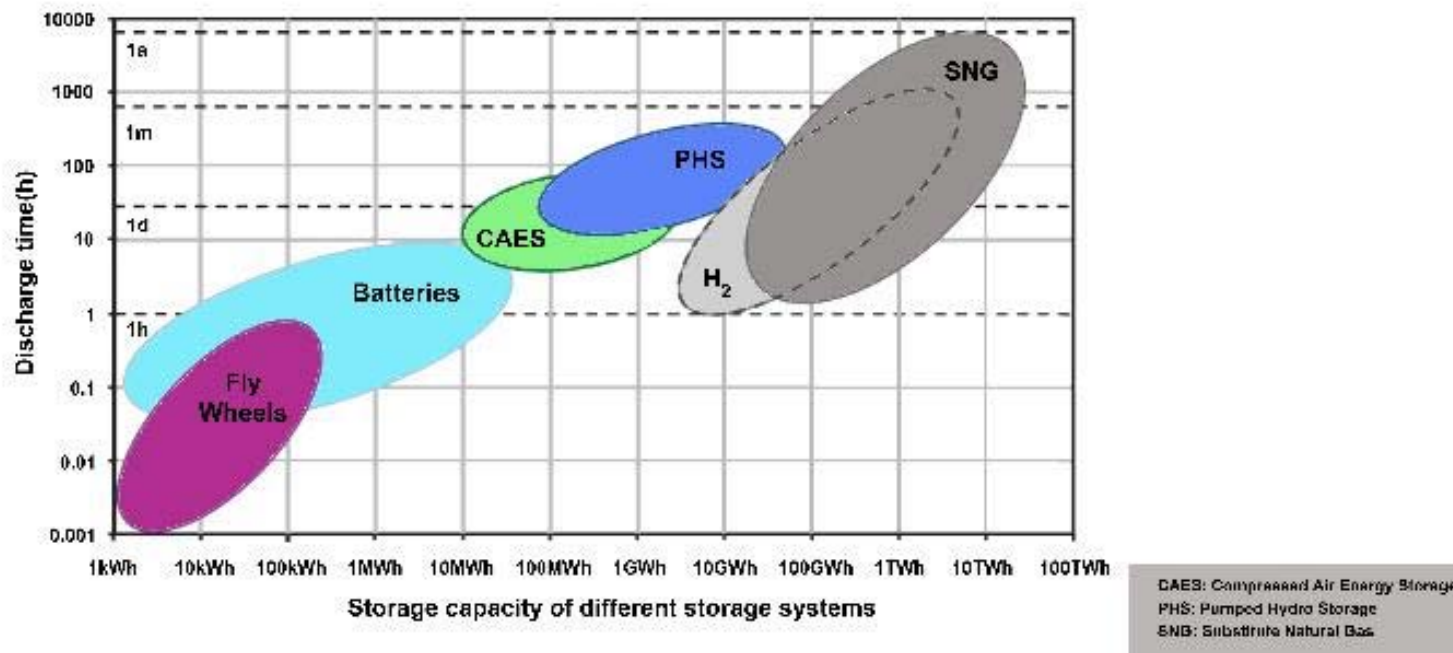

Energy storage/recovery

- Negative residual loads (Renewables > Demand)
- Energy storage or H₂ supply to industry (Power to Gas)

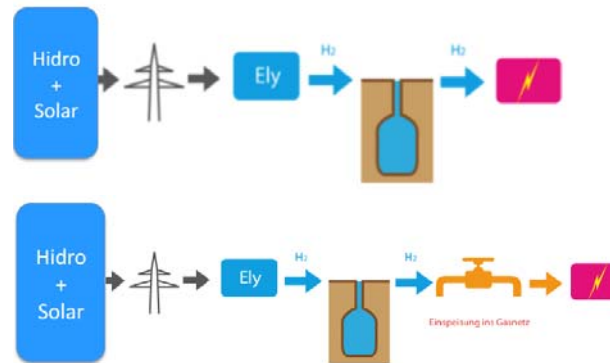

- Positive residual loads (Renewables < Demand)
- Hydrogen stored reversion to electricity

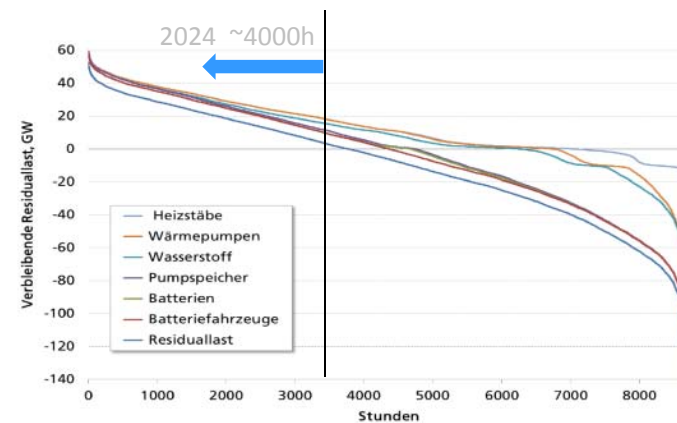
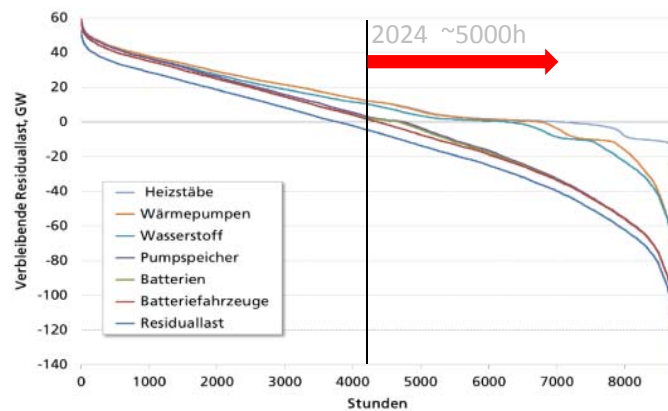

Power to Gas also for Isolated Systems in Brazil

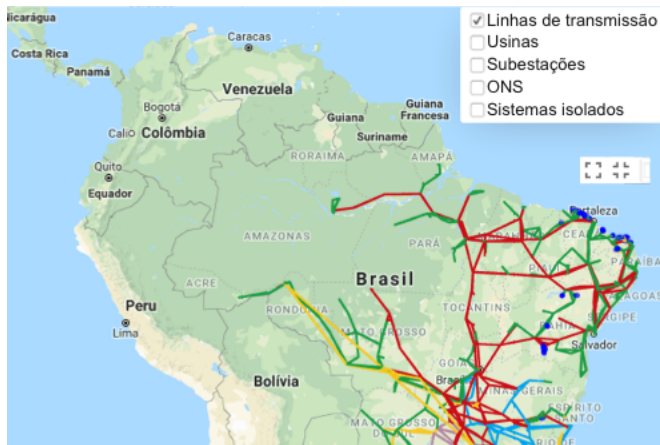

Power to Gas in Amazon isolated systems

- Hydrogen production at hydropower plants in Amazon region
- Transportable cylinders to supply internal combustion engines in isolated systems
- Savings of over R\$ 4 billion/year by avoiding diesel transportation from refineries to isolated areas

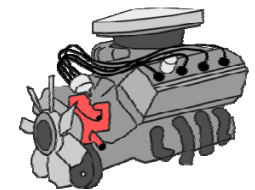
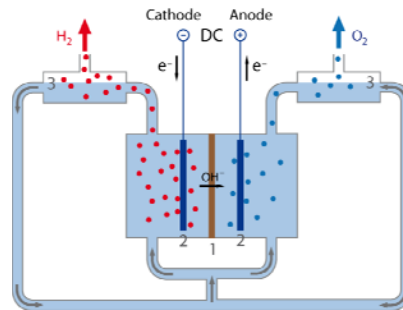
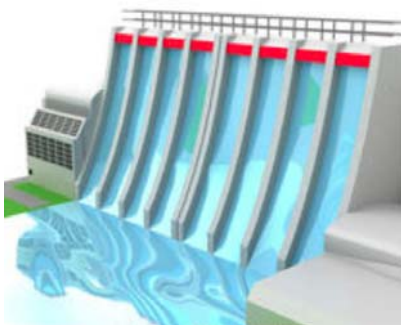

Source: <http://moziru.com>, Mcphy, Setis, Clipground

A Regional Power to Gas Strategy for South America



Source: ELETROBRÁS

Regional strategy

- Energy integration based on hydropower plants
- Hydrogen production from surplus hydroelectricity, potential do produce over 2.7 million Nm³ H₂/year, equivalent to 15 GWh/year of Clean, Zero emissions electricity that can be made available in the Region
- Power to Gas
 - Natural Gas vs Hydroelectricity regional optimization
- Replace fossil fuels consumption in isolated power systems
- Potential to reduce 0.1 Gton CO_{2eq}/year

Latin America and Caribe 50% Renewable / 50% Fossil

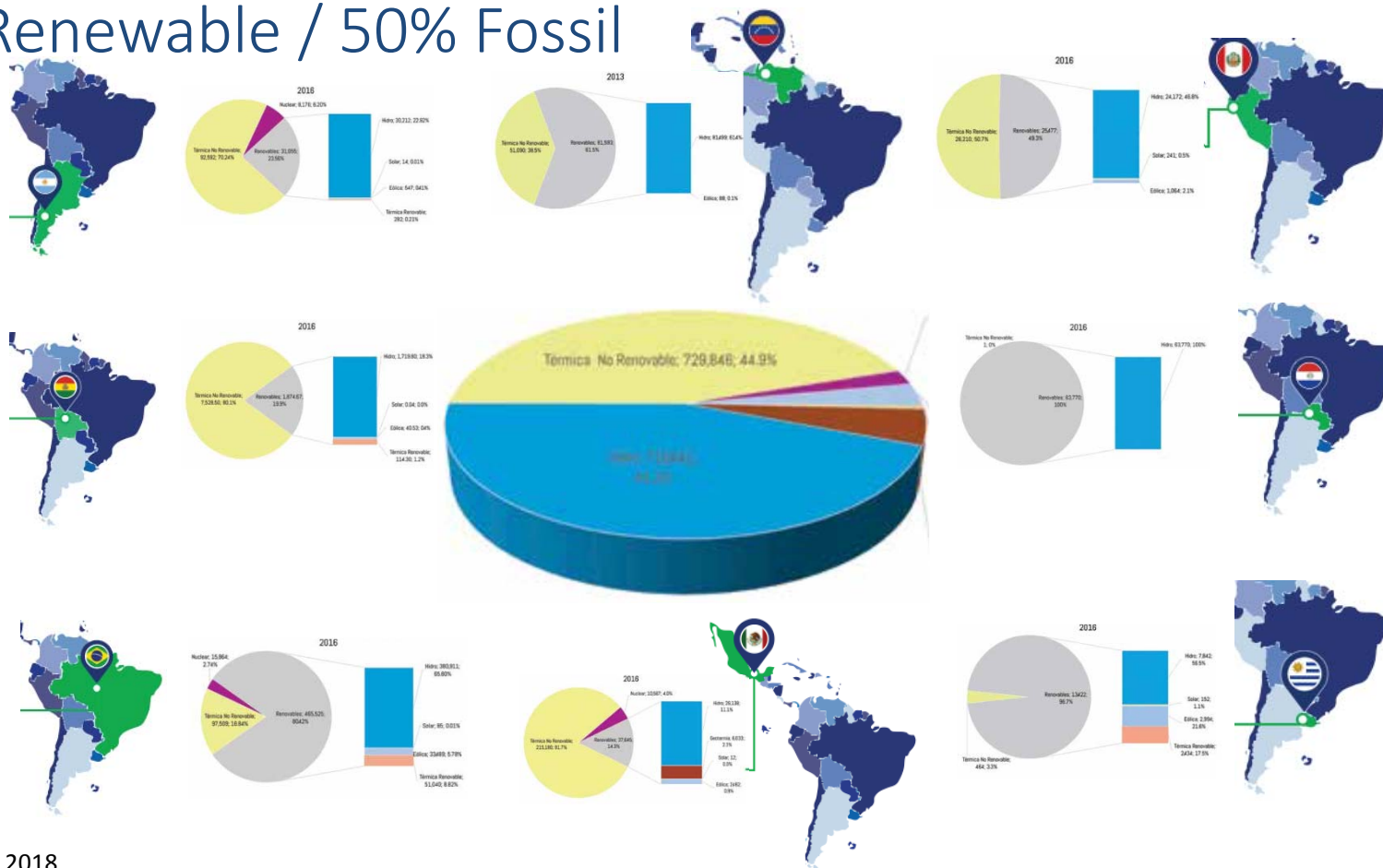

Source: OLADE 2018

Latin America and Caribe

Opportunity to move ahead towards Hydrogen Energy based Economy



27 Countries

- Argentina
- Barbados
- Belize
- Bolivia
- Brazil
- Chile
- Costa Rica
- Equator
- El Salvador
- Granada
- Guiana
- Haiti
- Honduras
- Jamaica
- Mexico
- Uruguay
- Venezuela
- Colombia
- Guatemala
- Nicaragua
- Panama
- Paraguay
- Perú
- Republic Dominican
- Suriname
- Trinidad Tobago

Conclusions

- Arguments for Hydrogen Energy strategies are increasingly stronger
- Brazil and Latin America have enormous potential to get benefits from such strategies
- Hydrogen Energy Based Economy is becoming into reality, but depend on market players engagement
- Rationale for Power to Gas seems to be feasible in the Region at short term
 - Market and Governments engagement should push ahead initiatives

Thank You

Dr. Demóstenes Barbosa da Silva
demostenes.silva@basengenharia.com.br
+55 11 98555-8969
+55 11 3045-8235