

P170526

# Technical training material and presentations.

**Assessment of Suitable Flood Mitigation Measures (based on Dukniskhevi River Extreme Flood Analysis) in Tbilisi, Georgia**

CTCN REFERENCE NUMBER: 2016000043



**Document Information**

Date	29.07.2018
HYDROC project no.	P170526
HYDROC responsible	Juan Fernandez
Client	CTC-N/UNIDO
Reference No.	2016000043
Project No.	
Credit No.	

**Contact**

HYDROC GmbH  
Siegum 4  
24960 Siegum  
Germany

Tel - +49 172 450 91 49

Email - [info@hydroc.de](mailto:info@hydroc.de)

## Contents

1	Introduction .....	1
2	Presentations and Materials .....	2
2.1	Hydrological Modelling handout and presentations given during the Training .....	2
2.2	Hydraulic Modelling handout and presentations given during the Training .....	213

## 1 Introduction

The main objective of this consultancy is to improve the flood risk management in the Leghvtakhevi River basin in Tbilisi (Georgia). This will be accomplished through the implementation of a modelling framework, the inclusion of climate change impacts, the definition of flood maps and the designation of flood mitigation and adaptation measures. Capacity building and technology transfer activities will be undertaken too, and will be at the core of the project.

This consultancy started in August 2017 and is due to finish in August 2018 (duration of 12 months). The contract between UNIDO and HYDROC was signed on the 14th of August 2017.

This technical assistance is managed by the CTC-N, the National Designated Entity is the Ministry of Environment and Natural Resources Protection of Georgia, while key stakeholders are the National Environmental Agency Request (request applicant), the Tbilisi Municipality and the Emergency Management Agency under the Ministry of Internal affairs.

This report includes the training materials and presentations used during these training sessions.

## 2 Presentations and Materials

### 2.1 Hydrological Modelling handout and presentations given during the Training

P170526

# Hydrological Modelling Training Handout

Assessment of Suitable Flood Mitigation Measures (based on Dukniskhevi River Extreme Flood Analysis) in Tbilisi, Georgia

CTCN REFERENCE NUMBER: 2016000043



Version 2 – Part 1 and Part 2



P 170526

**Document Information**

Date	23.05.2018
HYDROC project no.	P170526
HYDROC responsible	Jens Kiesel
Client	CTC-N/UNIDO
Reference No.	2016000043
Project No.	
Credit No.	

**Contact**

HYDROC GmbH  
Siegum 4  
24960 Siegum  
Germany

Tel - +49 172 450 91 49  
Email - [info@hydroc.de](mailto:info@hydroc.de)

P 170526

## Contents

1	Training schedule and contents – Part 1 – Data processing .....	4
1.1	Overview of works, data and software distribution .....	4
1.2	Daily precipitation processing and return period estimation.....	4
1.3	Sub-daily precipitation data processing.....	5
1.4	Spatial data processing .....	6
1.5	Input data preparation for the Leghvtakhevi using HEC-GeoHMS .....	9
2	Training schedule and contents – Part 2 – Modelling .....	15
2.1	HEC-HMS introduction, setup and model runs.....	15
2.2	Sensitivity Analysis – Algorithms, input and parameter changes.....	18
2.3	Model calibration in Vere and parameter transfer.....	19
2.4	Simulation of design events in Leghtvakhevi and Knowledge Test .....	20
2.5	Own work, discussions, outlook and wrap-up of the Training .....	21

# 1 Training schedule and contents – Part 1 – Data processing

## 1.1 Overview of works, data and software distribution

A) Presentation of the works carried out with focus on the data used, data gaps, arising uncertainties and implications for decision makers.

Topics covered:

- Why hydrological modelling: predictions, scenarios, design
- Task definition and objectives
- Background and introduction to hydrological modelling: Theory, model types, data?
- Which model is suitable for this project?
- Available data and its quality in the Leghtvakhevi and Vere: spatial datasets, precipitation data, discharge data
- How to deal with the data gaps and what are the implications: Model calibration, sensitivity analysis and uncertainty
- Design events for baseline and climate change
- Outlook and discussion

B) Distribution and installation of software

- R 3.5.0
- R Studio 1.1.447
- QGIS 2.18. (if no other version of QGIS is installed or if you have ArcGIS installed and are proficient in its usage)
- HEC-HMS 4.2.1
- HEC-DSSVue 2.01
- Apache Open Office 4.1.5 (if no Excel or other version of Open Office is installed)

## 1.2 Daily precipitation processing and return period estimation

A) Kojori gauge stopped operation in 2005 and time series needs to be extended to 2016 to overlap with radar data. Daily rainfall data are supplied in “*MeteoData\_DLY.xlsx*” in three tabs for the three gauges “*Vashlijbari*”, “*Tbilisi Airport*” and “*Kojori*”.

Carry out the following steps:

- Find-replace “0T” (represents less than 0.1mm pcp) with “0” and “-99.9” with “#N/A” in all time series
- Plot the three time series in bar diagrams
- Create a new tab (“*Correlation*”) and therein a time series column spanning the full range (01/01/1961 – 12/31/2016) since we need a continuous, gapless time series
- Use the function  
“=IF(VLOOKUP(A2,Kojori!\$E\$2:\$I\$16437,5,FALSE)=”,#N/A,VLOOKUP(A2,Kojori!\$E\$2:\$I\$16437,5,FALSE))” for all three gauges to refer to the original data right next to the newly

established data column. The 'IF' statement is necessary to also catch blank (empty) cells and designate those as "#N/A", which are otherwise converted to "0".

- Calculate correlation between the three time series to check the relation between the three gauges: Apply a filter to pairs of gauges to filter out "#N/A" and "-99.9", copy both to new columns and calculate the correlation coefficient in three cells with "`=CORREL(array1,array2)`".
- For the best matching correlation (Vashlijvari and Kojori), calculate the trendline equation through plotting both datasets in a scatter plot (x=Vashlijvari, y=Kojori) and "Add trendline", force through 0 through setting intercept to 0.0 (to not change zero precipitation).
- Use the regression equation to calculate the Kojori time series based on Vashlijvari and substitute all missing values through the calculated time series, e.g. with "`=IF(ISNA(D2),E2,D2)`".
- Check and discuss the result
- For which dates would you order radar data?

## B) Calculating precipitation return period intervals

For the final time series, precipitation return periods need to be calculated using extreme value statistics. The calculation is carried out using the freely available software R and R-Studio.

Carry out the following steps:

- Use a pivot table to calculate the annual maximum daily precipitation for each year
- Convert the values to a comma-separated string (e.g. save to .csv)
- Enter the values to the R-function "`ReturnPeriods.R`", which is to be opened in R-Studio
- Check the return periods to be calculated in line 42
  - 2,5,25,50,100,500
- Run the script line by line, check T-Test results, plot the values, check best fit of distributions, open the output file in Excel
- Check and discuss the result

## 1.3 Sub-daily precipitation data processing

Presentation with brief theoretical background of precipitation radar data and explanation of the Wradlib Python library

A) Time series radar data extraction:

- Copy the content of the folder "`...\Day03_SubDaily_PCP_Processing\RadarData\RadarFiles_160923`" to "`...\Day03_SubDaily_PCP_Processing\RadarProcessingSoftware\RadarFiles`"
- Click on the file "`extract_radar_rainbow_Compiled.exe`"
- Do not printout reflectivity (type "n")
- Select slice "0"

- Repeat the process for a higher slice (e.g. "8") and another set of radar files (e.g. "RadarFiles\_161117", make sure to delete the previous files in folder "RadarFiles" first) for both slices

#### Analysis of time series:

- Import the output csv file to Excel or LibreOffice and plot all time series
- Check and discuss the result, save the file
- In what elevation does the radar beam observe precipitation in the Leghtvakhevi?  
Radar station Longitude / Latitude = 45.879,41.626  
Radar station elevation = 1080m ASL  
Distance radar station to Leghtvakhevi = 100km

#### B) Extract data at a different location

- Backup / rename the file "... \RadarProcessingSoftware\ExtractionPointsRadar.txt"
- Add the shapefile "... \RadarPointsLocation\RadarPoints\_4326.shp" to the GIS
- Select points where you want radar data time series to be extracted
- Open the attribute table and copy the selected entries, paste in a notepad and save the tab delimited file as "... \RadarProcessingSoftware\ExtractionPointsRadar.txt"
- Carry out the extraction for slice "0" as described under A)
- Compare the result with A)

#### C) Disaggregation of the 100yr return period

- Open the Excel file from A) and import the value for the 100yr RP from the first day
- Calculate the sum in mm/day for the radar time series and calculate the correction factor
- Multiply each value of the radar time series with the correction factor
- Plot and discuss the result

#### D) Spatial data extraction

- Select two time steps with high and low precipitation and make sure to have only those two ".vol" files in the folder "RadarFiles"
- Run the extraction program and select "y" to print out reflectivity values
- Repeat for a higher slice number
- Import the csv files to QGIS, save to a shapefile and apply the style file provided in "... \Day03\_SubDaily\_PCP\_Processing\ReflectivityStyleTemplate\StyleRadarReflectivity.qml"
- Compare and discuss the results

## 1.4 Spatial data processing

### A) Elevation data

- Import the DEM to the GIS
- Resample to 5m grid cell for faster processing
  - We can use the SAGA Function “*Resample*” from the Toolbox using “*bilinear*” settings

## B) Land use data

Prepare the landuse shapefile according to the following information:

- Reclassification to hydrologically meaningful attributes, e.g. using satellite images:

Original	Reclassified
CEMETARY	ForestLight
FOREST_LITE	ForestLight
GROUND	ForestLight
LAND	ShrubMeadow
LARGE_CITY	UrbanHigh
LARGE_RIVER	Water
ROCKY	Rocks
SCRUB	Shrub
SMALL_CITY	UrbanLow
URBAN_PARK	Shrub
LAKE	Water
ORCHARD	ForestLight

- Assigning land cover attributes<sup>1</sup> to the classes

Landuse	Impervious area ratio (%)	Canopy storage (mm)	Surface storage (mm)
ForestLight	0	2.5	1.0
ForestDense	0	3.0	1.0
Water	100	0.0	0.0
ShrubMeadow	0	2.0	1.0
Shrub	0	1.5	1.0
Rocks	90	0.0	0.5
UrbanHigh	60	0.0	0.2
UrbanLow	40	0.0	0.5

- Create one table in Excel that links the “*Original*” land use values to the attributes (use the VLOOKUP function as shown in “*Reclassify.xlsx*” in the folder “*04\_SpatialData\_Processing\Landuse\*”) and save as “.csv”
- Use Join in QGIS (right click layer, “Properties” and select “Join” in the tabs and join the according fields)

<sup>1</sup> Maidment DR. 1993. Handbook of Hydrology. McGRAW-Hill Inc.

- Use the field calculator to add new fields “RECLASS”, “ImpArea”, “CanStor” and “SurStor” with calculating numbers from the original joined fields (which are text)
- Convert the landuse shapefile to grids for each of the three attributes

### C) Soil data

- Add the definition of Hydrologic Soil groups according to the NRCS<sup>2</sup> to the soil shapefile by adding a field “HSG” and type in the Hydrologic Soil Groups

Catchment	Soil Types / Texture	Hydrologic Soil Group
	Brown forest soils, heavy loam and clayey	D
	Cinnamonic, heavy and medium loam	CD
Leghtvakhevi	Brown forest soil, weathering of sedimentary rocks	C
	Meadow-field, heavy loam and clayey	D
	Cinnamonic, weakly developed, developed on loessial loams	C

- Union the landuse and soil shapefiles using the Processing Toolbox SAGA tool “Polygon union” (do not tick split parts)
- Open the attribute table and check the fields – note that polygons with empty fields are created, select those, start editing and delete selected
- Use the field calculator to add a field (Text, length 20) and use the expression “HSG”+’\_’+ “RECLASS” to calculate the field that contains both the hydrologic soil group and the Reclassified landuse
- Add the estimated saturated hydraulic conductivity (Ks) values for the soil and land cover combinations (derived from <sup>2</sup> and <sup>3</sup>) and the CN-Values (derived from <sup>1</sup>) to the shapefile:
  - Copy the below table to Excel
  - Rename the column headings to a short description (e.g. HSG\_LU, KS\_mm\_hr, CN)
  - Save the table as .csv
  - Join the .csv to the shapefile and calculate new fields with ks and CN values (for CN-values, use the expression “to\_int( “Ks\_CN\_CN” )” see detailed explanation for join under B).

<sup>2</sup> United States Department of Agriculture, Natural Resources Conservation Service. 2007. Part 630 Hydrology, National Engineering Handbook, Chapter 7, Hydrologic Soil Groups.

<sup>3</sup> Jarvis N, Koestel J, Messing I, Moeys J, Lindahl A. 2013. Influence of soil, land use and climatic factors on the hydraulic conductivity of soil. Hydrol. Earth Syst. Sci. 17

Hydrologic Soil Group	Land Cover	HSG_LandCover	Saturated hydraulic conductivity (Ks) [mm/hr]	CN Values
CD	ForestLight	CD_ForestLight	6	77
CD	Shrub	CD_Shrub	4	80
CD	ShrubMeadow	CD_ShrubMeadow	3	82
CD	UrbanHigh	CD_UrbanHigh	3	86
CD	UrbanLow	CD_UrbanLow	3	83
C	ForestLight	C_ForestLight	10	71
C	Rocks	C_Rocks	0	98
C	Shrub	C_Shrub	8	74
C	ShrubMeadow	C_ShrubMeadow	5	76
C	UrbanHigh	C_UrbanHigh	5	82
C	UrbanLow	C_UrbanLow	5	80
C	Water	C_Water	0	100
D	ForestLight	D_ForestLight	1.25	80
D	Rocks	D_Rocks	0	98
D	Shrub	D_Shrub	1	85
D	ShrubMeadow	D_ShrubMeadow	0.5	87
D	UrbanHigh	D_UrbanHigh	0.5	91
D	UrbanLow	D_UrbanLow	0.5	89

- Convert the soil shapefile with both the attribute saturated hydraulic conductivity and CN value to grid

#### D) Create a 2-yr rainfall grid

- Take the 2-yr return period precipitation in mm/d and transfer to inches/d (divide by 25.4)
- Use the raster/map calculator to add to the raster mask (which has value 0)

## 1.5 Input data preparation for the Leghvtakhevi using HEC-GeoHMS

In the following, a very detailed step-by step procedure is given how HEC-GeoHMS is used to prepare the base model for the Leghtvakhevi HEC-HMS model

### General comments and preparation

- Software versions used here: HEC-GeoHMS 10.2 in ArcGIS 10.2
- Activate HEC-GeoHMS: Customize - Toolbars - HEC-GeoHMS
- Add raw DEM in correct projection to View and save ArcGIS Project
- Be sure to use relative path names and store project versions along the process including their geodatabase in separate folders

- Be sure to use simple, short path names with no spaces, numbers as first character or other special characters (e.g. C:\Temp\Legh)
- Disable background processing<sup>4</sup>
- If crashes occur, check if layers are in edit mode and if yes, close editing and repeat
- If not otherwise stated, use default naming convention / suggested names from HEC-GeoHMS
- In case of crashes or unexpected behaviour, check the known issues: [http://www.hec.usace.army.mil/software/hec-geohms/known\\_issues.aspx](http://www.hec.usace.army.mil/software/hec-geohms/known_issues.aspx)
- and helpful collection of workarounds: <https://community.esri.com/thread/43771>

### HEC-GeoHMS Menu h

- Preprocessing into a Geodatabase (create new File Geodatabase Catalog - browse to folder - right click - New file Geodatabase and save derived rasters and shapefiles into the database)
- DEM Reconditioning Agree Method needed since streams are not well defined in the DEM (input: RawDEM, Merged Streams of Vere and Leghvtakhevi, 5, 10, 300, Negative No)
- Build Walls (only needed if previously delineated subbasins must be used - not needed here)
- Fill Sinks (input: AgreeDEM, no threshold, no deranged Polygon)
- Flow Direction (input: FilledDEM, no Outer Wall Polygon)
- Flow Accumulation (input: FlowDir)
- Stream Definition (input: FlowAcc, Threshold 0.2km<sup>2</sup>)
  - if catchments/streams are not linked: select streams with the raster calculator:
  - SetNull("Fac","Fac","Value <= 600000"), resulting grid \*0+1 and continue with the processes
- Stream Segmentation Link (input: Streams, FlowDir, optional empty)
- Catchment Grid Delineation (inputs: FlowDir, StreamLink)
- Catchment Polygon Processing (inputs: Catchment grid)
- Drainage Line Processing (inputs: StreamLink, FlowDir)
- Adjoined Catchment Processing (inputs: DrainageLine, CatchmentPolygon)
- this project and its geodatabase can be the source to any new HEC-HMS project within the area

### HEC-GeoHMS Menu - Project Setup

- Data Management
  - Check if all layers are correctly found in the drop down menus
- start new Project (e.g. Legh)
  - Project Area: LeghArea and Project Point: LeghPoint
  - Project Name: Legh
  - Description: Leghtvakhevi Catchment
  - Extraction Method: Original Stream Definition

---

<sup>4</sup> <https://maybeitsamap.wordpress.com/2015/04/29/quick-tip-021/>

- Project Data Location: Folder at location of project file (likely to crash within Geodatabase)
- Add Project Points
  - click the pin button to add an outlet at the location where Leghvtakhevi enters Vere: LeghOutlet
- Generate Project
- Create Project area for shown location, if area of catchment is correct - all names default.

### HEC-GeoHMS Menu - Basin Processing

- From now on, store all HEC-GeoHMS output in the newly generated project database
- Data Management
  - populate drop down menus
- Carry out custom subbasin delineation to add outlets at location of hydraulic model inputs
  - manually add points at desired subbasin locations directly on flow accumulation streams (use custom symbology with 'Classified' and two classes, Classify at e.g. 1000 cells as black, other white)
  - add the hydraulic modelling points shapefile
  - click the A++button to add points on the stream network
  - merge subbasins if small, unwanted subbasins are created
  - if this causes small additional streams to remain (cannot be get rid of through stream merge) delete the wrong one manually (start Editing via the Editor toolbar first) and take care that from to-connections are correct, NextDownID is the HydroID of the downstream stream section, set potentially missing DrainID similar in both Subbasin1.shp and River1.shp
- Correct grid\_code of River1.shp if different from subbasin gidcode (is needed for TR55 calculations)
  - either manually or through spatial join (HAVE THEIR CENTER IN) and export to same geodatabase where River1.shp is located
  - If subbasin layer contains NULL values for GRIDCODE, populate through calculating "Equal to "OBJECTID" (check if duplicates are not created!)
- Populate <Null> arcid values being equal to grid\_code (check that duplicates are not created!)

### HEC-GeoHMS Menu - Characteristics

- calculate slope grid using ArcHydro Toolbar: Terrain Preprocessing -> Slope using RawDEM, PERCENT\_RISE
- run all options (Data management, River length, river slope, basin slope, longest flowpath, basin centroid, centroid elevation, centroidal longest flowpath)
- check calculation of stream slopes - correct to 0.001 and DownEle = UpEle - length\*slope if negative
- If longest Flowpath Calculation of HECGeoHMS crashes, use Filled DEM, different target locations (outside Geodatabase). If that does not work carry out longest flowpath calculation in ArcHydro („Watershed Processing” – “Longest Flow Path”. If that does not work, try all layers outside of geodatabases, repair subbasins shapefile, check if all fields in subbasin

shape are populated. Check that no editing session is active. Save LongestFlowpath result in geodatabase of current project

- Basin centroid calculation (store in different geodatabase if process crashes) and check the location of the centroids – if not plausible, either try different method or move manually (start editing and move point)
- Calculate centroid elevation
- Calculate centroidal longest flowpath using the HEC-GeoHMS or ArcHYDRO generated flowpath

### HEC-GeoHMS Menu - Parameters

- Data Management: Populate existing layers (not all needed, can also be done later when running the respective process)
- Select HMS Processes:
  - Initial + Constant
  - Modified Clark
  - Monthly constant
  - Kinematic Wave
- Run River Auto Name and Basin Auto Name
- Grid cell processing
  - use SHG and default grid cell size and projection
  - Populate Flow Direction Grid and Subbasin, Flow Length Grid not needed, set to “Null”
  - Process may take long without message to finish
- Subbasin Parameters from Raster: Add only the data needed:
  - 2-year Rainfall Grid
  - Percentage Impervious Grid
  - Constant Loss Grid (= Saturated hydraulic conductivity)
- Check in Subbasin1.shp attribute table if all subbasins have been calculated - if not, enter values manually (happens for small subbasins)
- Subbasin Parameters from Features: Not needed
- Muskingum Cunge and Kinematic Wave Parameters: distinction in three groups according to river order:
  - River Order 1 and 2: Small tributaries:
    - Bottom width: 1.5m
    - Side slope (xH:1V): 2
    - Mannings n: 0.045
    - Shape: Trapezoid
  - River Order 3 and 4: Leghtvakhevi main channel and large tributaries
    - Bottom width: 4m
    - Side slope: 1
    - Mannings n: 0.04
    - Shape: Trapezoid
  - River Order 5: Vere main channel
    - Bottom width: 15m
    - Side slope: 1
    - Mannings n: 0.035
    - Shape: Trapezoid

- TR55 Flow Path Segments (all default)
- TR55 Flow Path Parameters (all default)
- TR55 Export to Excel
  - correct slopes and Mannings n (estimating or copying from River1.shp - replace 0 by 0.001)
  - correct missing 2yr rainfall values
  - correct negative values
  - go to AddIns and export to Subbasin1.shp
- If export does not work, save table as csv (Name and TimeOfConc) and join to Subbasin:
  - Transpose the table to a new sheet (Copy - paste special - paste special - checkValues and Transpose)
  - Delete all fields but not Watershed Name and not Watershed Time of travel (hr)
  - Rename fields to WNAME and TC\_hr
  - Join fields: Subbasin „Name“, csv Table “WNAME”
  - Open attribute table and calculate Tc field and remove join

### HEC-GeoHMS Menu - HMS

- Check Data Management if existing layers are correctly linked
- Map to HMS Units
  - If BasinHeader is not found, copy the table from the most recent default geodatabase into every previously used Database using ArcCatalog
  - Use „SI“ Units for HMS Unit Conversion
- Check Data- if data problems found check the log-file and go back to the respective step to fix the issues:
  - repeat the process
  - manually digitize and snap river connections, move outlet point to the most downstream end of reach
  - move centroids – then re-calculate basin centroid elevation, centroidal longest flowpath
  - rename IDs (DrainIDs of River1 and Subbasin1 shape must match, NextDownID must be HydroID of downstream reach
  - if no error in river connectivity are found, i.e. the points are correctly snapped to the topoint of the reach, then proceed since HEC-GeoHMS has issues in identifying river connectivity
- Create HMS Schematic (see impact of toggle legend)
- Carry out Add coordinates
- Prepare Data for model export (choose yes if files need to be overwritten)
- Create Background Shapefiles
- Create Basin Model file
- Create Grid Cell File
- Select MET Model File as Specified Hyetograph
- Create HMS Project
  - Location as simple folder, e.g. C:\Temp\Legh\_HMS
  - Basin File: created .basin file
  - Met File: created .met file
  - Gage File: created .gage file
  - HMS Run Name: default

- Simulation Start Date Time / End Date Time and Time Interval leave as default since it can be changed in HEC-HMS
- If import to HEC-HMS does not work:
  - Try different model algorithms (e.g. no KinematicWave)
  - open with HEC-HMS 3.5 in very simple folder (e.g. C:\Temp\)
  - manually delete any unconnected items in the HEC-HMS schematic
  - copy / save project, open with HEC-HMS 4.2.1 and save again in final folder

## 2 Training schedule and contents – Part 2 – Modelling

### 2.1 HEC-HMS introduction, setup and model runs

This session will explain how to customize the HEC-HMS view and the model and how additional data that is not provided by HEC-GeoHMS is additionally input into the model's graphical user interface (GUI) and how it is stored and accessed in the file structure

#### A) Introduction to the menu structure, customizing the view

- Open the provided HEC-HMS project in *"06\_HEC-HMS\_Introduction\HECHMS\_FromGeoRAS\"* with HEC-HMS 4.2.1. We will together browse through the first 11 pages of the Quick Start Guide: click *"Help – Quick Start Guide"*
- We will take a look at the menu structure and the entries in each menu
  - Under *"Edit"*, play around with the *"Arrow"*, *"Zoom"*, *"Pan"* and the *"Select special..."* tools
  - Under *"View"* we will add the subbasin shapefile as *"Background maps..."* for better orientation, play around with the *"Zoom"* and *"Draw"* tools
  - The *"Components"* menu entry is used to access, modify and extent the main model components
  - Under *"Parameters"*, the model's parameters are stored for the different algorithms, including the *"Zone configuration"* (useful for calibrating large basins) and *"Computation Point Manager"* (useful for calibration at a specific point)
  - Under *"Compute"*, HEC-HMS contains different management tools to run the model – we will only use the *"Simulation Run Manager"* (*Optimization* is only useful if observed data are available, *Forecast Alternative* is used for forecasts utilizing different meteorologic inputs, *Depth Area* analysis is used to pick exceedance intervals from continuous simulations, *Uncertainty Analysis* is used to assess the impact of parameter uncertainty of unique elements)
  - Under *"Results"* the main outputs are shown in a tabular or graphical manner for selected elements or for the whole model
  - *"Tools"* menu is used to obtain reports for basin model and simulation runs, delete results, compress results and adjust settings. We will change, under *"Defaults"* the *"Element sorting"* to *"Alphabetic"*
  - The *"Help"* menu is used to link to the HEC-HMS manuals and additional information
- We will take a look at the watershed explorer and the three tabs *"Components"*, *"Compute"* and *"Results"* different objects *"Basin Models"* (with subbasins, junctions, reaches, sinks), *"Meteorologic Models"* (with specified Hyetograph for each subbasin), *"Control specifications"* (with the time series properties) and the *"Time-Series data"*
- The component editor shows the details for each selected component / object of the watershed explorer
- Create a new simulation run by going to *"Compute"*, *"Create Compute"*, *"Simulation Run..."* and name it *"Default"*
- Go to the *"Compute"* tab and select the *"Default"* run
- Carry out the HEC-HMS run by *"Compute"* *"Compute run [Default]"*

B) Populating missing data in the Leghtvakhevi model that is not covered or transferred from HEC-GeoHMS. Important (!): When copying and pasting data from tables (Excel or GIS), make sure that the “*Sorting*” in the Parameter windows is always set to “*Alphabetic*” (!)

- Check all processes of the “*Parameters*” menu and take note which parameters contain no values
  - Set the sorting to alphabetic and copy all rows to the respective excel tab in the file “*06\_HEC-HMS\_IntroSetup\ExcelFiles\Parameterization\_Legh.xls*”
  - Use the GIS function “*Zonal Statistics*” to derive the average (“*mean*”) values of all missing parameters for each subbasin, copy the result to Excel, in a separate tab for each process (source data in “*05\_Simplified\_HEC-GeoHMS\SourceData\*”)
  - Enter a realistic number for the initial storages of the Surface and Canopy methods and a conservative number for the initial loss of the Initial and Constant Loss method
  - Calculate the “*Storage Coefficient*” of the “*ModClark Transform*” method using the information in the Excel File “*06\_HEC-HMS\_IntroSetup\ExcelFiles\Parameterization\_Legh.xls*”, tab “*ModClark*” and the subbasin shapefile (copy the attribute table from the “*\GISFiles\Subbasin1.shp*” to the SUBBASIN tab in the Excel file. For info: Longest flowpath in Subbasin shape provided through spatial join with the longest flowpath shapefile).
  - “*Constant Monthly Baseflow*” values are assumed to be the same over the whole year. We assume the same baseflow contribution per area as in the Vere, where about 2.6m<sup>3</sup>/s fast and slow baseflow contributions exists for the 175km<sup>2</sup> catchment.
  - Note: the “*Invert*” and “*Diameter*” parameters of the “*Kinematic Wave Routing*” are not needed
- Input of precipitation data
  - HEC-GeoHMS creates a time series precipitation gauge for each subbasin. Since we are using only one rain gauge, this makes it tedious to change rainfall input
  - Check the entries of the “*Precipitation Gauges*” under “*Time-Series data*” – we require only one gauge (Kojori). Since manual deletion via the GUI is cumbersome, use the “*Legh.gage*” ASCII file from the HEC-HMS project folder in a text editor and delete all gauges that are not needed
  - Also, check the linked “*Specified Hyetograph*” for each subbasin and gage under the “*Meteorologic Models*” – “*Legh*” entry in the “*Watershed Explorer*” – we need to assign the one gauge to each subbasin. This can be done manually (tedious) or opening the “*Legh.met*” file in Excel and carry out filtering of “*Gage:*” (make sure to have 5 whitespaces) lines and fill out the “*Gage: Precip Gage 1*” to the bottom and export as Text (MS DOS).
  - For the one remaining “*Precip Gage 1*”, change the time series properties in the Component editor and add data:
    - Time Interval: 3 Minutes (“*Time-Series Gage*” tab)
    - Start Date: 01Jan2000 (“*Time Window*” tab)
    - Start Time: 00:01
    - End Date: 01Jan2000
    - End Time: 23:58
    - Add one of our radar options time series data (e.g. 17.11. RP100 in mm/3min) to the Table by copying from the Excel file “*\03\_SubDaily\_PCP\_Processing\#Backup\RadarResultProcessing.xls*”

- Why does it not align with the rows? Check the exact Radar time step in the file "*RadarTimeSeries.xlsx*"
- Create a new, correct time series (00:01:00, and " $=FIRSTCELL+1/24/60*3$ ", fill out to bottom)
- link data to the original with VLOOKUP, set option to "*TRUE*" to get approximate result
- Enter time series to HEC-HMS and check it visually in the graph tab
- Adjust the "*Control Specifications*" "*def\_control*" time window:
  - Start Date: 01Jan2000
  - Start Time: 00:01
  - End Date: 01Jan2000
  - End Time: 23:58
  - Time Interval: 3 Minutes
- Create a new simulation run by going to "*Compute*", "*Create Compute*", "*Simulation Run...*" and name it according to the respective RP that was entered for the precipitation gauge (e.g. "*RP100\_19.11*")
- Carry out the HEC-HMS run by "*Compute*" "*Compute run [xxx]*"
- If the model does not run due to the error that precipitation values are missing, check the precipitation time series and if all numbers are populated go to "*Meteorologic Models*", "*Legh*" and then set "*Replace Missing*" to "*Set to Default*".

#### C) Accessing and interpreting results

- Check results from the HEC-HMS GUI
  - Select any element from the basin model
  - Click the icons "*View global summary table*", "*View Graph for selected elements*", "*View summary table for selected elements*", "*View time-series table for selected elements*" in the menu bar
  - Repeat for different upstream to downstream objects and discuss the results
- Check results using the HEC-DSS software
  - Open *HEC-DSSVue*, go to "*File*" "*open*" and browse to the *.dss* file in the HEC-HMS model folder
  - Double click on different rows (you can also select multiple ones) and visualize and export the data using the four icons
  - Discuss results of different hydrological components

#### D) Bonus: Results analysis exercise:

- Have a look at the paper of Grimaldi et al. and look at the different definitions for "Time of concentration" and analyse the following:
  - Look at the distribution pattern of the rainfall and runoff – which rainfall peak causes which runoff peak?
  - Check the time difference between the respective peak in rainfall and the peak in runoff in the model
  - How well does it correspond to the Leghtvakhevi's time of concentration calculated from the TR-55 method?

## 2.2 Sensitivity Analysis – Algorithms, input and parameter changes

Prepare one Excel file “SensitivityAnalysis.xlsx” with one tab for each sensitivity investigation (“LossMethod”, “TransformMethod”, “RoutingMethod”, “Precipitation”, “Parameters”)

Keep track of the parameter settings in the file “HECHMS\_Parameters\_SensitivityAnalysis.xlsx” and calculate the maximum peak (the time series can also be plotted). After checking one sensitivity result, always go back to the default model again.

### A) Impact of algorithms

- Open and run the “RP100\_19.11” of the “HECHMS\_Legh\_BASE\_MODEL”
- Copy the outflow of reach “R2750” into each Excel sheet – this is the default discharge time series to which we compare the changes
- Change method from Initial and Constant Loss Method to SCS-CN Loss method
  - Populate the CN numbers for each subbasin through “Zonal Statistics” on the subbasin shapefile (“\GISFiles\Subbasin1.shp”) and the “\04\_SpatialData\_Processing\#Backup\CN.tif”
  - Note: We set the initial abstraction 0 and Impervious area also 0 since the impervious areas are already included in the composite curve number (see Table 2-2a of the Technical Report 55 NRCS USDA)
  - Run the model and copy the results to the respective Excel sheet – analyse and discuss the result
  - Switch the Loss method back to “Initial and Constant” and copy the original parameters to the Loss parameter window
  - Bonus exercise: Carry out the comparison for different Return Period events
- Change method from ModClark Transform Method to SCS-UH method
  - Leave graph type at “Standard” since the “Delmarva” is for slow reacting, flat basins only
  - Calculate the SCS-UH lag time in the Excel file with the Tab “Transform” using the suggestion of the HEC-HMS user manual: “lag time can be computed as the duration of unit precipitation divided by two plus 60% of the time of concentration”
  - Run the model and copy the results to the respective Excel sheet – analyse and discuss the result
- Change method from Kinematic Wave routing to Muskingum Cunge routing
  - Kinematic Wave and Muskingum-Cunge use the same parameters (Invert not needed)
  - Populate the values, carry out the run and compare in the Excel sheet and discuss the result

### B) Sensitivity of precipitation (Rainfall input is provided in Excel file “Precipitation\_Options.xlsx”)

- How sensitive is discharge to the different radar disaggregation options? The 19.11 – event is radar option 5
  - Run all additional four radar events in the model and compare the results
- How sensitive is the model to different time steps?
  - Enter the aggregated 3-minute rainfall of the RP100 to 6, 15, 30 minutes, 1 hr, 6 hr, 1 d to HEC-HMS and adjust the simulation time step and precipitation data time step
  - Compare and discuss the results.

### C) Sensitivity of input parameters

- Check the following examples for the Loss method:
  - Worse case: No soil permeability, constant loss rate would be 0
  - If soils would be one hydrologic soil group different towards more permeable soils? ("*04\_SpatialData\_Processing\Soils\SaturatedHydraulicConductivit.xlsx*"), this would be on average constant loss rate times 5
  - If no saturated conditions exist prior to the storm, i.e. Initial Losses would be 50mm over the whole catchment
- Check the following examples for the Transformation method:
  - Check the sensitivity of the time of concentration calculations to higher return period events (enter the 100yr RP instead of the 2yr RP in inches to the excel file "*Tc\_Sensitivity*")
  - According to the paper regarding the Time of Concentration calculation by Grimaldi et al. (2012), assume we use a method that leads to half the Time of Concentration
- Check the following hypothetical examples for the routing method:
  - If the channel would overgrow with weeds, Mannings'n could reach 0.1
  - If the stream would be channelized with concrete, Manning'n could become 0.013

### D) Analyse the Excel table and rank the sensitivity results

- Create a new table that contains a row for each method / parameter group and add the minimum and maximum values
- Plot and discuss the result

## 2.3 Model calibration in Vere and parameter transfer

### A) Introduction to the Vere model

- Open the HEC-HMS model "*\08\_HEC-HMS\_VereCalibration\HECHMS\_Vere\Vere.hms*" in HEC-HMS
- Get familiar with the model, its properties, input data and settings, e.g. check the observed flow time series linked to the Outlet

### B) Calibration events preparation

- Get familiar with the Excel file "*Vere\_Flow\_PCP\_Analysis\_AND\_PCP\_ForCalibration.xlsx*"
  - Check the hydrograph and precipitation – and the selection of the storm events
  - Correlation between discharge and PCP
  - The calculated runoff ratio and it's change over time
  - The accumulation curve of rainfall vs runoff
  - Understand how the time series of the three events was created
- Calculate the antecedent moisture conditions (expressed in our case as the "*Initial Losses*" for the Loss method "*Initial and Constant*") for the three storms

- Therefore, the potential evapotranspiration (PET) is a positive component (adding to the deficit), and rainfall a negative component (reducing the deficit)
- Use a simple PET calculation that is based on temperature (e.g. the Thornwaite equation, <https://ponce.sdsu.edu/onlinethornthwaite.php>)
- Calculate the long-term monthly average temperatures using the Excel file "*ClimateVashlijvari\_Daily.xlsx*" and enter the values in the respective format in the online PET calculator, read the latitude from e.g. Google Earth, Google Maps, or QGIS
- The calculated moisture deficit represents the Initial losses and can be entered to the file "*LossMethodValues\_Vere.xlsx*"

### C) Carrying out calibration

- Calibration in the Vere can only be carried out for discharge volumes, since no information on peak flows or other sub-daily information was available
  - Open the HEC-HMS Vere model in the folder "*08\_HEC-HMS\_VereCalibration\HECHMS\_Vere\_Default\*"
  - Create new control specifications for the three events (has to cover the full time period and in 3-min intervals)
  - Create new precipitation time series and add the respective time series for each event separately
  - Run the model for each event and note the Volumes at the outlet in an Excel sheet (Summary Results for Sink "*VereGage*", "*Computed Results*" and "*Observed Hydrograph*" Volumes)
  - Check the Volumes for the different rainfall distributions (Radar events) for the different historical events
  - Make a conservative selection of the target event that is used for calibration
  - Change the Constant Loss (ks, saturated hydraulic conductivity) until it matches the target

### D) Parameter transfer to Leghtvakhevi

- Carry out the same change in saturated hydraulic conductivity (constant losses) in the Leghtvakhevi model ("*08\_HEC-HMS\_VereCalibration\HECHMS\_Legh\_Default\*") – compare before and after!

## 2.4 Simulation of design events in Leghtvakhevi and Knowledge Test

### A) Simulating baseline and climate change events

- Investigate the design rainfall events and check the plausibility of the input, i.e. is it physically possible? ([https://en.wikipedia.org/wiki/List\\_of\\_weather\\_records](https://en.wikipedia.org/wiki/List_of_weather_records))
- Take care to use the correct outflow to obtain the peak at the outlet: Sum of outflow of R2750 and W2740!
  - Open the model "*HECHMS\_Legh\_FinalModel*"
  - Subsequently enter all design rainfall events from the Excel file "*DesignEvents\_RPs\_Vizualization.xlsx*" for the most conservative Radar

disaggregation option W5 (Info: The time series provided differ slightly from the training versions due to the different method for extrapolating the Kojori time series)

- Run each RPs in the same simulation (only one .DSS file is used)
- Open the HEC-DSSVue program and open the results .DSS file
- Select the two objects (R2750 and W2740) “FLOW” rows, go to “Groups” and “Save selected”, e.g. as “Legh\_Out”.
- Then go to “Groups”, “Math”, select one dataset above, tick “Data Set” option and select the second one. Operator must be “Add”, then click “Compute”
- Change the precipitation data and subsequently run the RPs, update the .DSS File
- Plot/tabulate the result, export to Excel
- Plot all results in Excel, extract the peak flow and discuss the result

#### B) Knowledge Test

- The test will be used to evaluate the knowledge you acquired during the training

#### C) Points that were raised by the participants to be discussed:

- Gridded precipitation input to HEC-HMS
- TR55 method for time of concentration calculation – theoretical background
- What causes different runoffs though rainfall is similar? – answer that question just from looking at data without modelling. Example from any catchment with appropriate data
- Which software to use for pre-processing of input data?
- How do we best simulate complex catchments?
- Free global data sources for regional modelling
- R script for calculating return periods
- Black holes (information paradox)  
<https://www.youtube.com/watch?v=yWO-cvGETRQ>

## 2.5 Own work, discussions, outlook and wrap-up of the Training

#### A) Continuation of own work

#### B) Outlook and summary presentation

- What can we do with the model next
  - Link to HEC-RAS
  - Continuous simulations  
(additional algorithms in HEC-HMS: ET, Snow, Groundwater, Soil Moisture)
  - What have we learned regarding the implementation of a Flash-Flood Early Warning System?
- Summary of training content
- Discussion

### C) Feedback, Evaluation

- Fill out the evaluation form (anonymous possible)
- Discussion and closing of the Training

14.05.2018 – 25.05.2018  
at Ilias State University

# Assessment of Suitable Flood Mitigation Measures in Tbilisi, Georgia

- Hydrologic Modelling Training -



Dr. Jens Kiesel  
jkiesel@hydroc.de



# Approximate training schedule

## Part 1 – Data processing



Session	Contents
1	Modelling process, results, uncertainty, recommendations - Summary for decisionmakers
	Training data provision, software installation
2	Daily (and sub-daily radar) precipitation data processing
3	Sub-daily precipitation radar data processing
4	Spatial input data processing
5	Demonstration of HEC-GeoHMS

# Approximate training schedule

## Part 2 – Modelling



Session	Contents
6	HEC-HMS algorithm selection and discussion
	HEC-HMS introduction (Menu items, objects, schematics, data import and change)
7	HEC-HMS model runs (creating runs, viewing output, HEC-DSSVue)
	Model calibration (Vere)
8	Parameter transfer to Leghtvakhevi model, sensitivity analysis
	Sensitivity analysis, plausibility checks
9	Design events theoretical background, running Baseline events
	Design events Climate Change
10	Outlook (continuous simulations, linking to HEC-RAS)
	Wrap-up and discussion

14.05.2018

# Session 1

- Overview of works and implications for decision making -



Dr. Jens Kiesel  
jkiesel@hydroc.de



# Content



- Why hydrological modelling?
- Task definition and objectives
- Essential theoretical background (short)
- Which model and approach is suitable?
- Available data and its quality
- Model calibration, sensitivity analysis and uncertainty
- Design events for baseline and climate change
- Discussion

# Content



- Why hydrological modelling?
- Task definition and objectives
- Essential theoretical background (short)
- Which model and approach is suitable?
- Available data and its quality
- Model calibration, sensitivity analysis and uncertainty
- Design events for baseline and climate change
- Discussion

# Why hydrological modelling?



- Keywords: “Tbilisi”, “Flood” ....



# Why hydrological modelling?

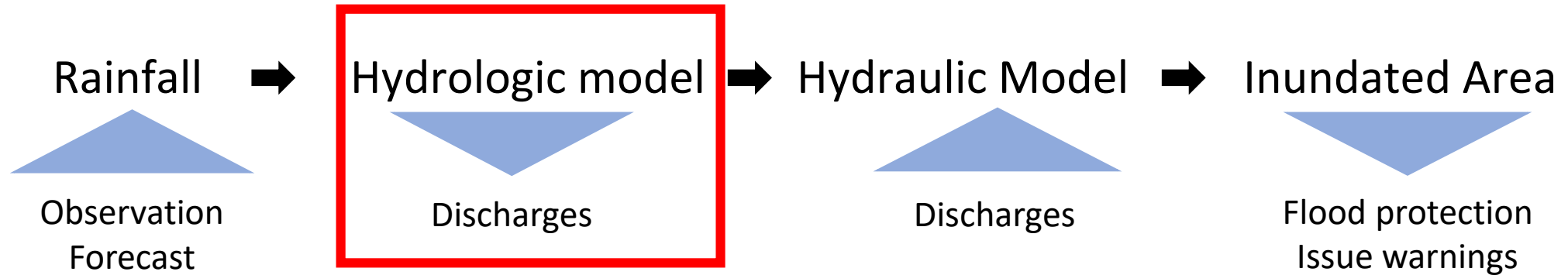

- Predictions of discharges
  - Impact of scenarios / changes on discharge
  - Key element for design of hydraulic structures / warnings
- ➔ Engineering: To find the optimum between safety and costs

# Content



- Why hydrological modelling?
- Task definition and objectives
- Essential theoretical background (short)
- Which model and approach is suitable?
- Available data and its quality
- Model calibration, sensitivity analysis and uncertainty
- Design events for baseline and climate change
- Discussion

# Project objectives



- Improving flood risk management in the Leghtvakhevi catchment
- Implementation of a modelling framework
- Including climate change impacts
- Preparation of flood maps
- Designation of flood mitigation and adaptation measures

# Project objectives

- Improving flood risk management in the Leghtvakhevi catchment
- Implementation of a modelling framework
- Including climate change impacts
- Preparation of flood maps
- Designation of flood mitigation and adaptation measures

## Objectives hydrologic modelling

- Simulation of baseline and climate change return period flood hydrographs
- Technology and knowledge transfer

# Content



- Why hydrological modelling?
- Task definition and objectives
- Essential theoretical background (short)
- Which model and approach is suitable?
- Available data and its quality
- Model calibration, sensitivity analysis and uncertainty
- Design events for baseline and climate change
- Discussion

# Background: Hydrological cycle

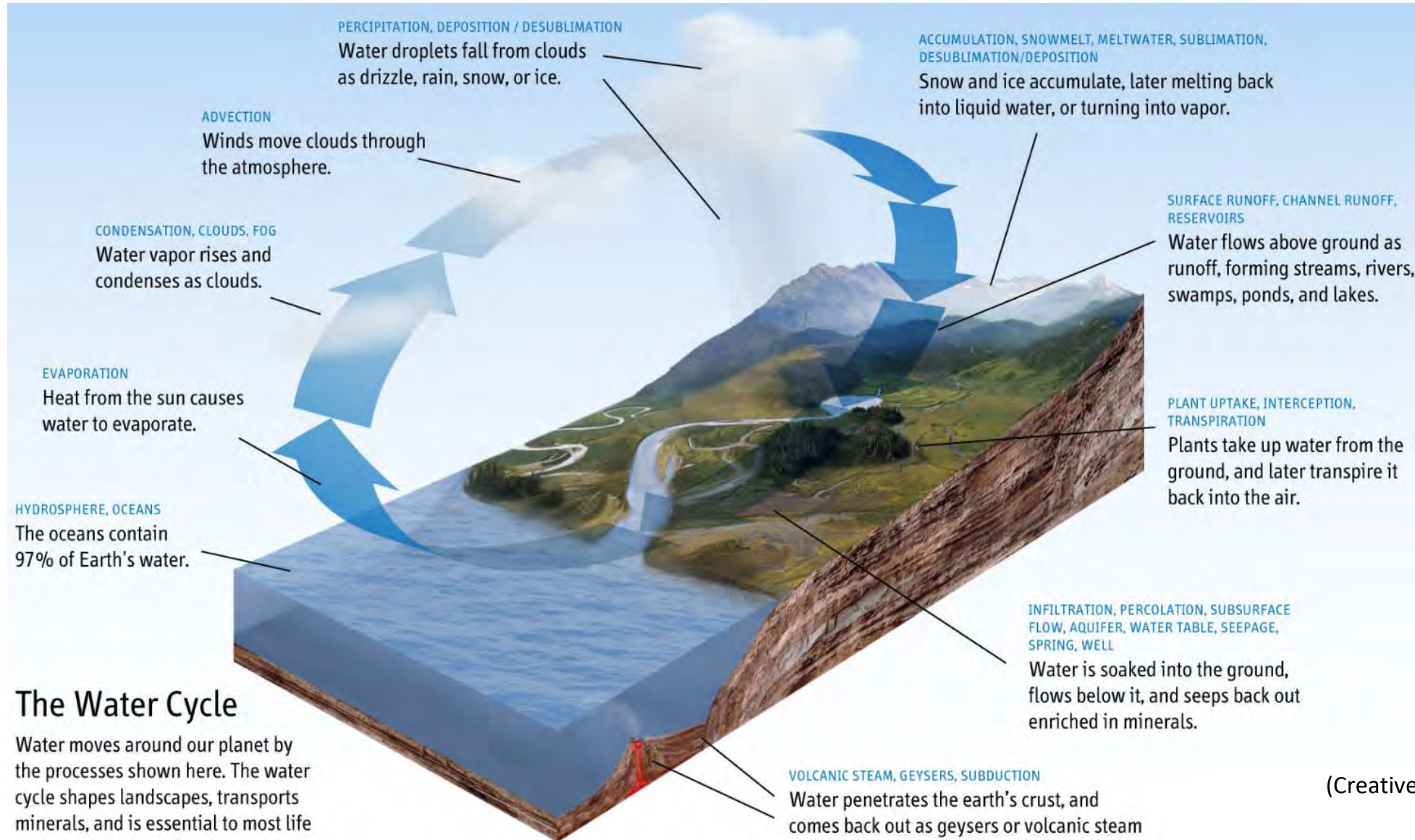

## The Water Cycle

Water moves around our planet by the processes shown here. The water cycle shapes landscapes, transports minerals, and is essential to most life and ecosystems on the planet.

(Creative Commons, 2018, Ehud Tal)

# Hydrological modelling



- Hydrological models can depict the full land phase of the hydrological cycle (general models)...
- ...or only parts of the hydrological cycle (e.g. flooding process) (specialized models)

➔ Focus on important and ignore negligible parts of the cycle depending on the task at hand

➔ Efficient modelling

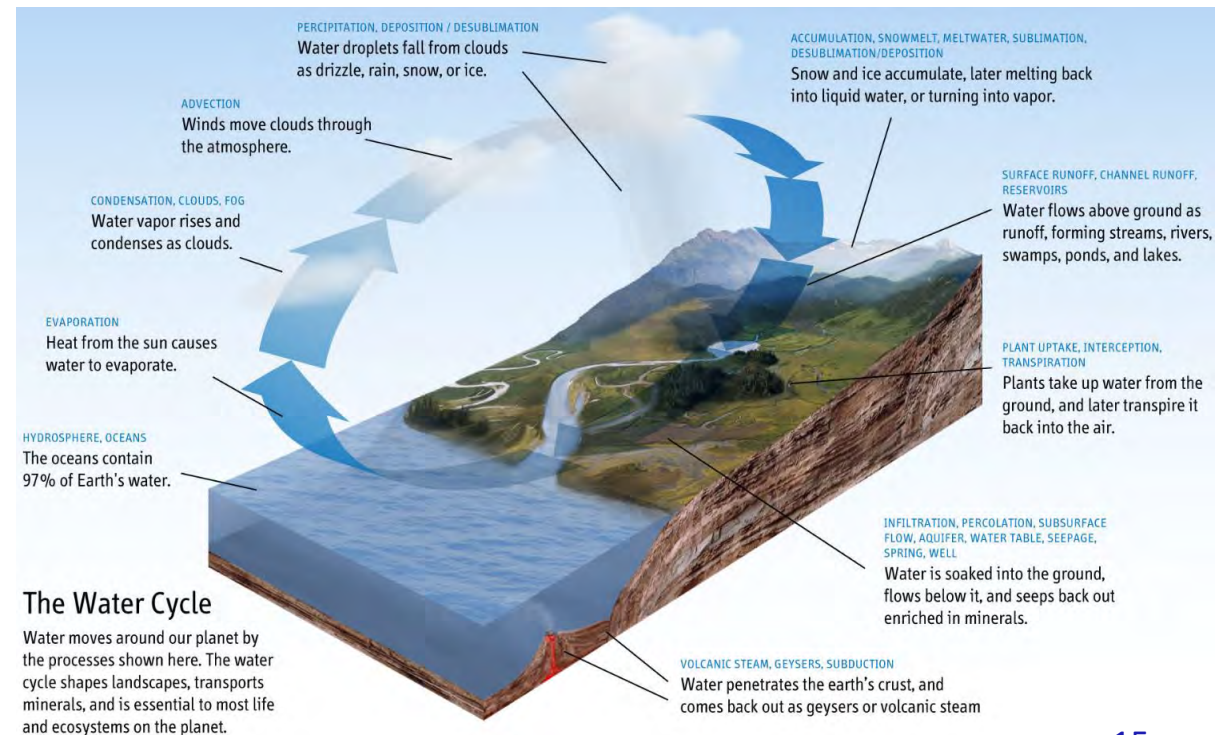

# Hydrological modelling cannot...



- provide a 100% exact solution to a problem
  - ➔ it will always remain a simplification of reality
- provide universal approaches to all types of hydrological problems
  - ➔ a specialized tool will always perform better than a general tool
- be a substitute for experience, knowledge and education of the hydrologist
  - ➔ (human) decisions are an integral part of any modelling process

# Classification of hydrological models



- Stochastic (random)  
Deterministic (explicit)
- Physically-based (hard to solve, less parameters)  
Empirical (simpler to solve, more parameters with mostly unknown ranges)  
Mixed
- Lumped (spatially averaged)  
Distributed (spatially explicit)  
Semi-distributed (lumped subbasins)
- Continuous (long time periods)  
Event-based (individual storm events)

# Model used in the project



- Stochastic (random)  
**Deterministic (explicit)**
- Physically-based (hard to solve, less parameters)  
Empirical (simpler to solve, more parameters with mostly unknown ranges)  
**Mixed**
- Lumped (spatially averaged)  
Distributed (spatially explicit)  
**Semi-distributed (lumped subbasins)**
- **Continuous (long time periods)**  
**Event-based (individual storm events)**

# Types of flooding



Coastal flooding



Pluvial floods



**River / flash floods**



Dam breaks

Creative Commons (2018)

# River floods and flash floods



- Two examples from last week:

<http://www.bbc.com/news/av/world-europe-44022350/turkey-floods-cars-swept-away-in-ankara-streets>

<https://www.youtube.com/watch?v=okol35u4pzE>

# Causes of river floods and flash floods



- Occurrence of exceptional discharge in river channels with breaching of river banks
- Caused by excessive rain or snowmelt upstream (dam break not considered here)
- Depends on interaction between
  - soil moisture
  - soil infiltration capacity
  - urbanization (impervious areas)
  - river channel properties
  - rainfall/snowmelt intensity

- Hydrate Project with data on Flash Floods

<http://www.hydrate.tesaf.unipd.it/index.asp?sezione=FFDCPresentation>

# Content



- Why hydrological modelling?
- Task definition and objectives
- Essential theoretical background (short)
- Which model and approach is suitable?
- Available data and its quality
- Model calibration, sensitivity analysis and uncertainty
- Design events for baseline and climate change
- Discussion

# Model requirements: River-, flash floods



## Modelling task in the Leghtvakhevi

## Required model properties

Simulation of representative flood flows

Event-based simulation

Possible integration into early warning system

Continuous simulation, batch-runs

Small catchments with rapid response times

Sub-hourly time step simulation

Linkage to a hydraulic model

Spatially distributed or semi-distributed

Possibly depict impact of dams

Reservoir simulation algorithms

Suitable to teach and long-term usage at NEA

User-friendly interface

standard Operation Systems

wide application range

well maintained and constant development

good documentation and help manuals

low maintenance costs

# Model selection: HEC-HMS



- Freely available from the United States Army Corps of Engineers (USACE) Hydrologic Engineering Center (HEC)  
<http://www.hec.usace.army.mil/software/hec-hms>

- 30 years of unprecedented experience in model development, it is HEC's major Hydrologic Modelling System (HMS)
- Model has a strong focus on flood modelling and engineering design (acknowledged by Federal Emergency Management Agency, FEMA)



US Army Corps  
of Engineers  
Hydrologic Engineering Center

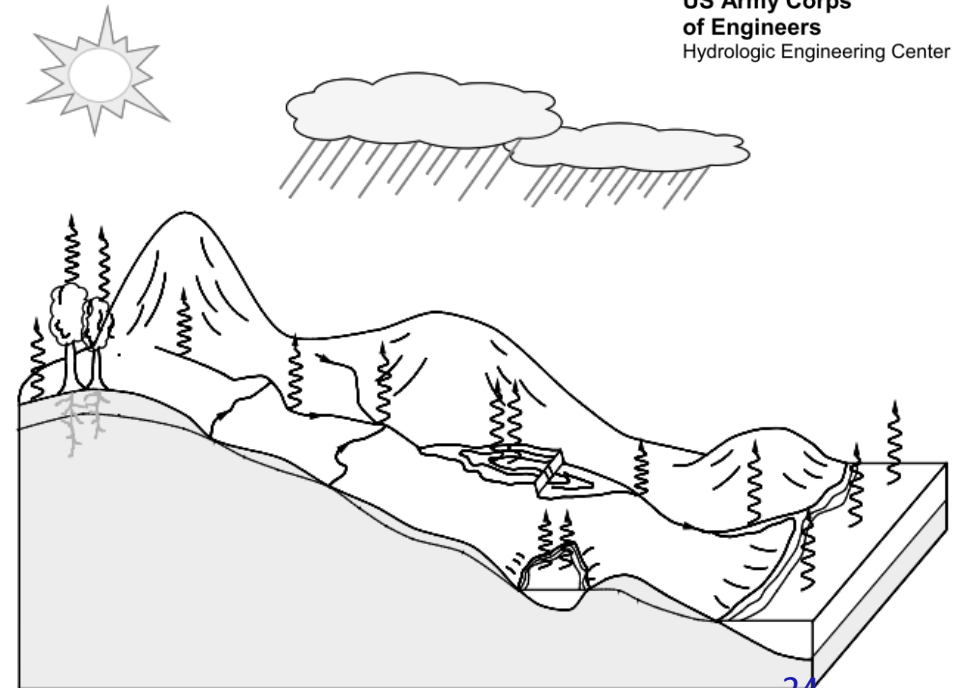

# Model selection: HEC-HMS



- Flexible software (multiple algorithms, continuous and event-based)
- Widely used due to constant development, GIS interface (HEC-GeoHMS), user groups and excellent documentation  
<http://www.hec.usace.army.mil/software/hec-geohms>  
<https://www.linkedin.com/groups/3863089>  
<http://www.hec.usace.army.mil/software/hec-hms/documentation.aspx>
- Linkage to other HEC models, e.g. HEC-RAS via the HEC-Data Storage System (DSS)

# Content



- Why hydrological modelling?
- Task definition and objectives
- Essential theoretical background (short)
- Which model and approach is suitable?
- Available data and its quality
- Model calibration, sensitivity analysis and uncertainty
- Design events for baseline and climate change
- Discussion

# Vere and Legthvakhevi catchment

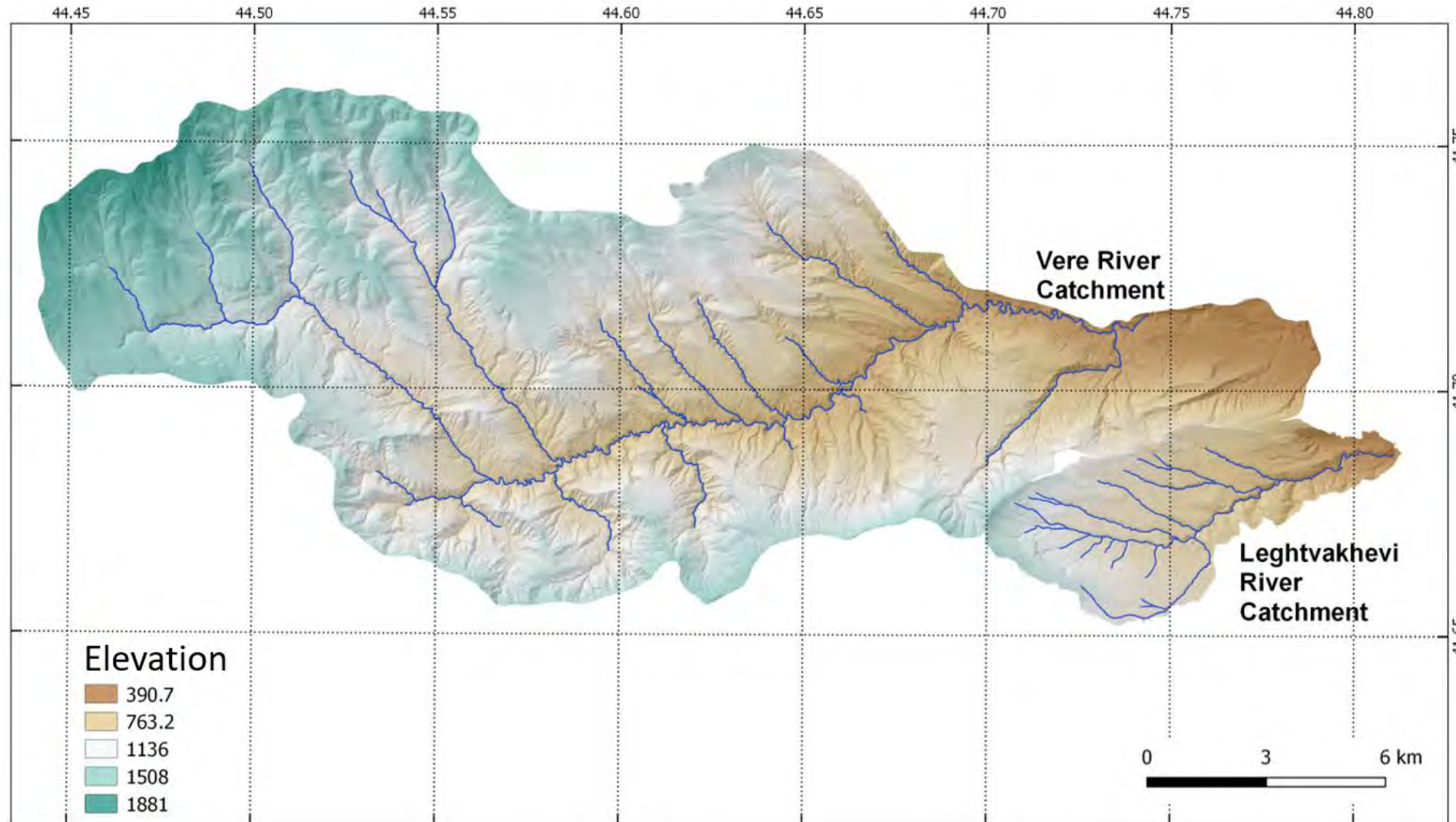

- 175km<sup>2</sup>  
24km<sup>2</sup>
- Steep gradients
- Western Tbilisi
- Discharge into Kura (Mtkvari)

# Legthvakhevi impressions



Light forest and shrubland



Arable land, urban areas



Accessible gorge downstream



Gorge from top with rock outcrops

# Available spatial datasets



---

<b>Description</b>	<b>Resolution</b>	<b>Source</b>
<b>Digital Elevation Model</b>	1m	Supplied by NEA
<b>Stream network</b>	Polygon (original resolution unknown)	Supplied by NEA
<b>Discharge locations for hydraulic model</b>	Point data	Derived within project
<b>Landuse map</b>	Polygon (original resolution unknown)	Supplied by NEA
<b>Google Earth images</b>	Around 1-10m	Google Earth
<b>Soil map and soil texture</b>	Polygon, 1:200000	Supplied by NEA

---

➡ **Data sufficient**

# Spatial data preparation

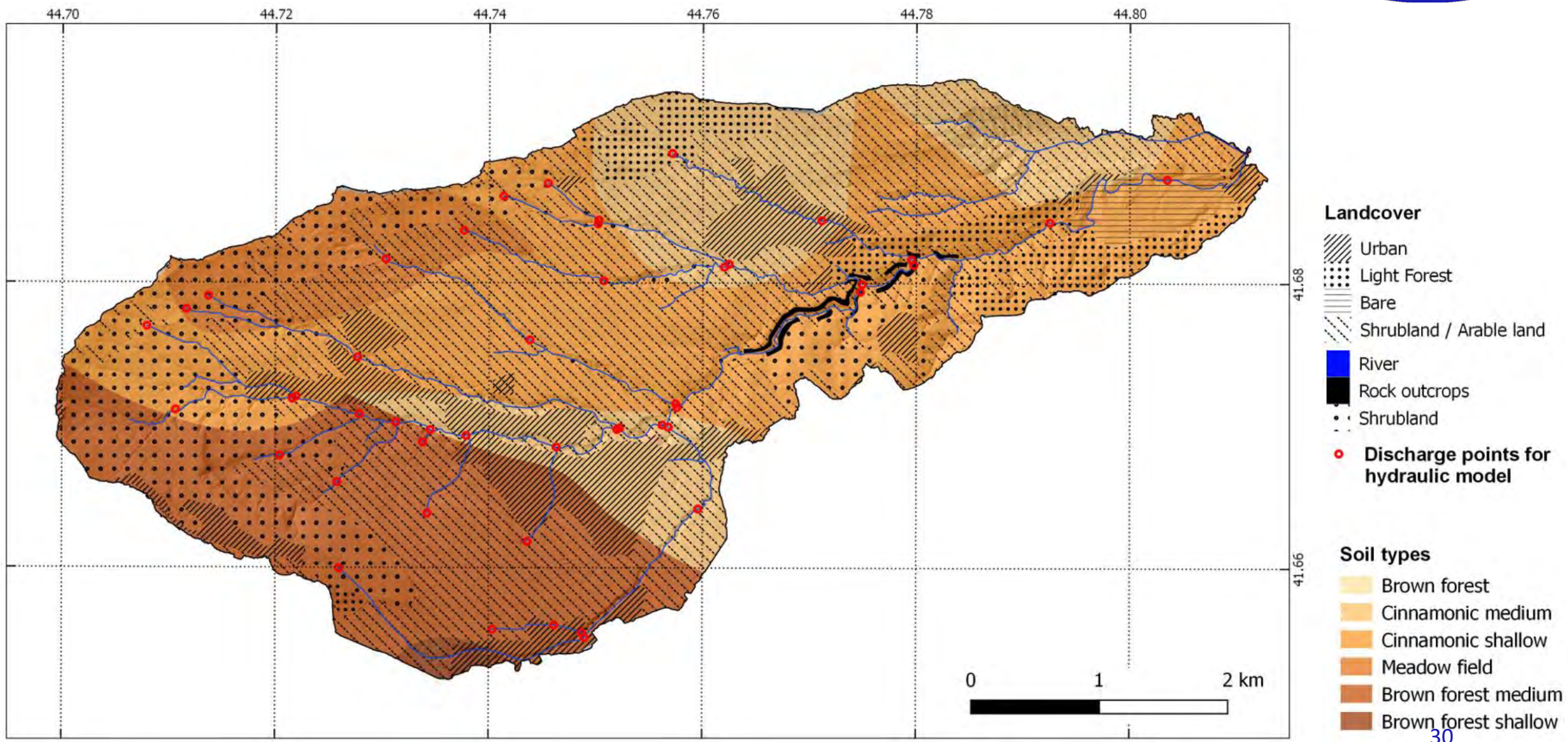

# Available temporal datasets



Description	Resolution	Source	Year
Daily precipitation data	Gauges Kojori, Tbilisi Airport, Vashlijvari	Supplied by NEA	Data ends in <b>2005</b> , 2016
Radar precipitation	3min temporal for five storm events	Supplied by NEA	<b>2016</b>
Daily discharge <b>Vere</b>	1 day	Supplied by NEA	Data ends in 2015

## ➔ Significant data gaps

- Daily precipitation in Kojori ends in 2005
- No sub-daily precipitation gauges
- No discharge observed in Leghtvakhevi => Necessary to simulate Vere catchment as well

# Kojori daily precipitation data extension

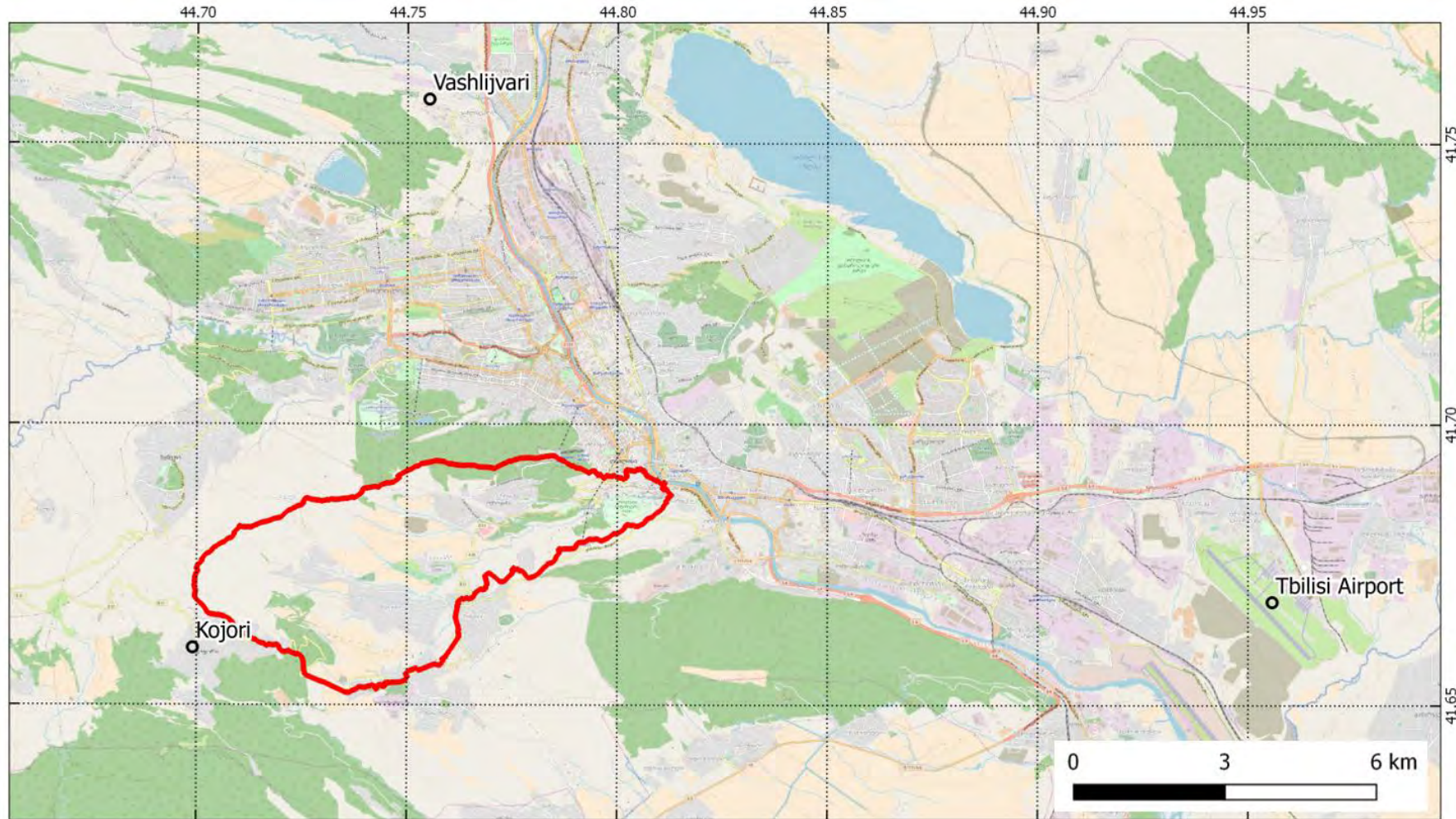

○ Location of precipitation stations  
□ Leghvtakhevi Catchment

Background: Open Street Map

Station	Elevation	Begin	End
Vashlijvari	427	1961	<b>2016</b>
Airport	462	1980	2010
Kojori	1381	1961	<b>2005</b>

## Correlation between daily precipitation time series

- Vashlijvari - Tbilisi Airport  
 $r = 0.62$
- Vashlijvari – Kojori  
 **$r = 0.73$**
- Tbilisi Airport - Kojori  
 $r = 0.57$

➔ Distribution Mapping to extend the Kojori time series up to 2016

# Problems arising from daily precipitation time steps in small catchments



„If **time steps** are chosen **too long**, the simulated **peak runoff** rate is systematically **too small**“

- Time steps should be smaller than the **Time of Concentration (ToC)** (time it takes a water drop from the farthest point to reach the outlet)  
=> for most subbasins in Leghtvakhevi, ToC is in the range of 10 minutes
- Precipitation, model time step, and discharge observations should ideally have the same resolution

# Problems arising from daily precipitation time steps



- **Daily** vs **subdaily** observed precipitation => Problem in simulation of runoff peak

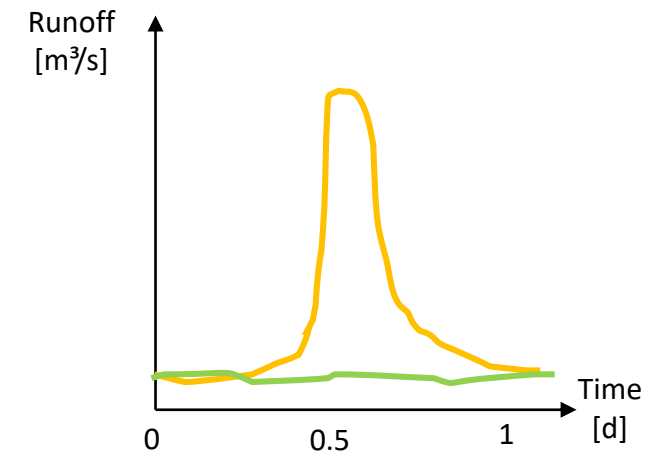
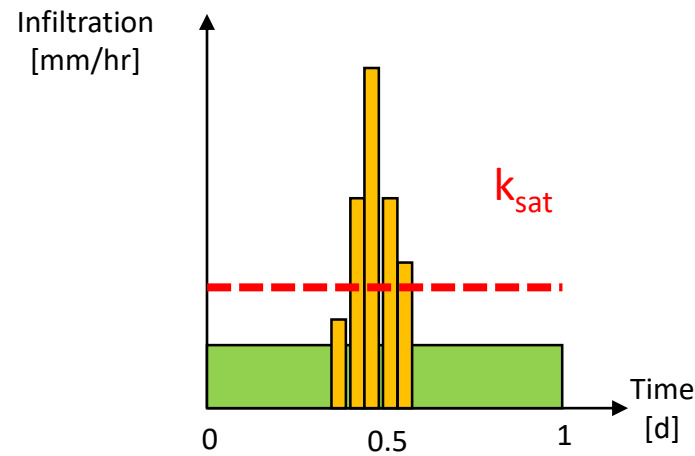
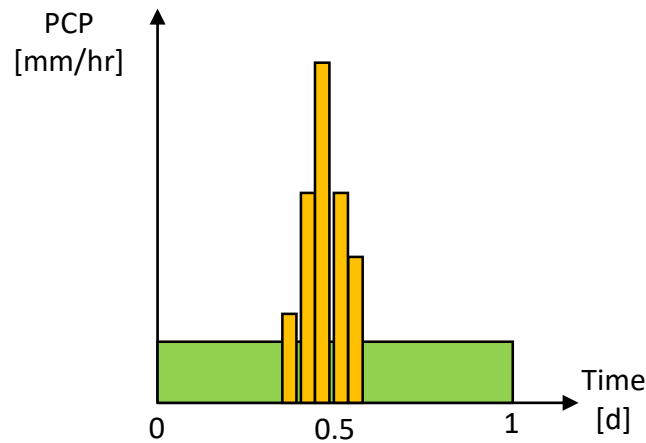

➔ We need to disaggregate (increase the resolution) of the daily precipitation time steps

# Utilizing data from rainfall radar

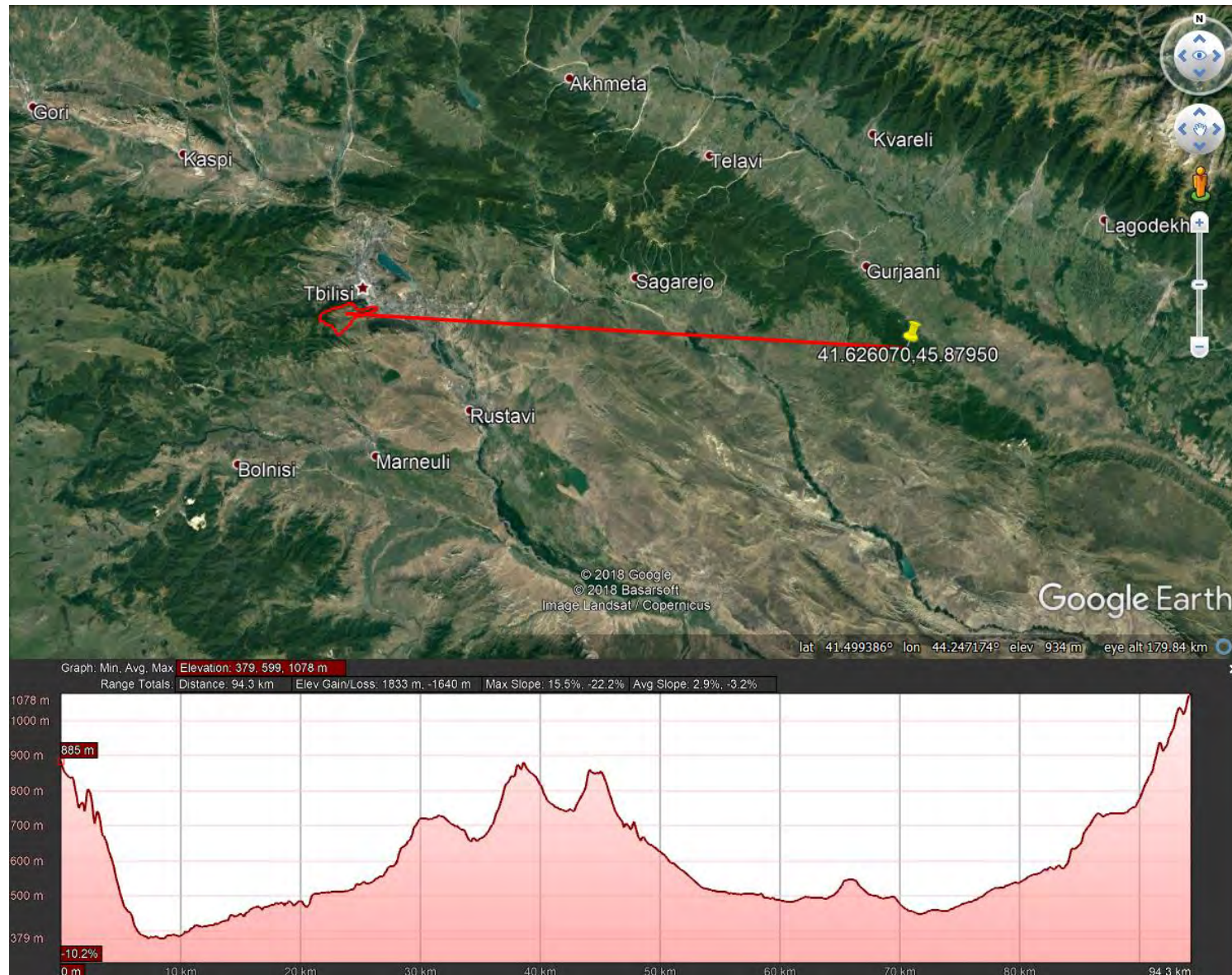

- Rainfall radar about 100km east of Tbilisi
- 3min intervall
- Since 2016
- Example reflectivity:

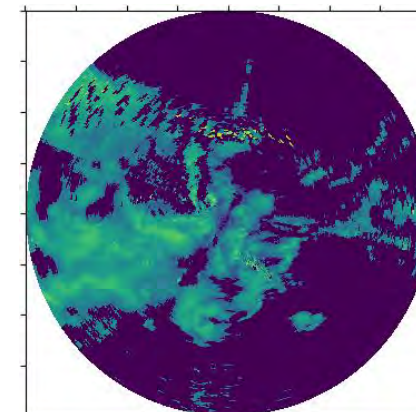

# Extracting data for Leghtvakhevi

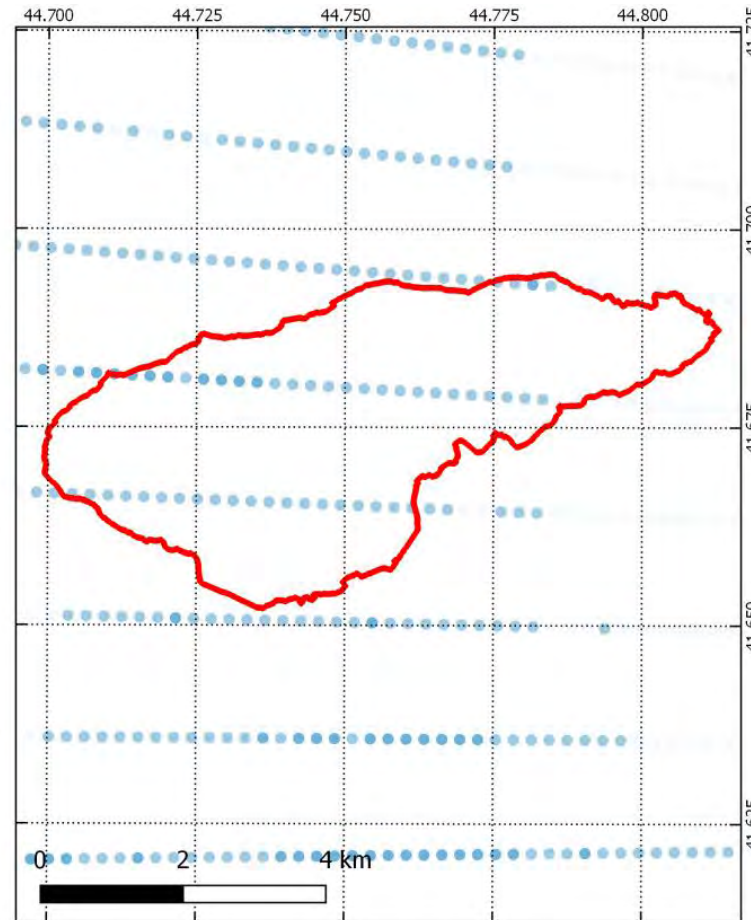
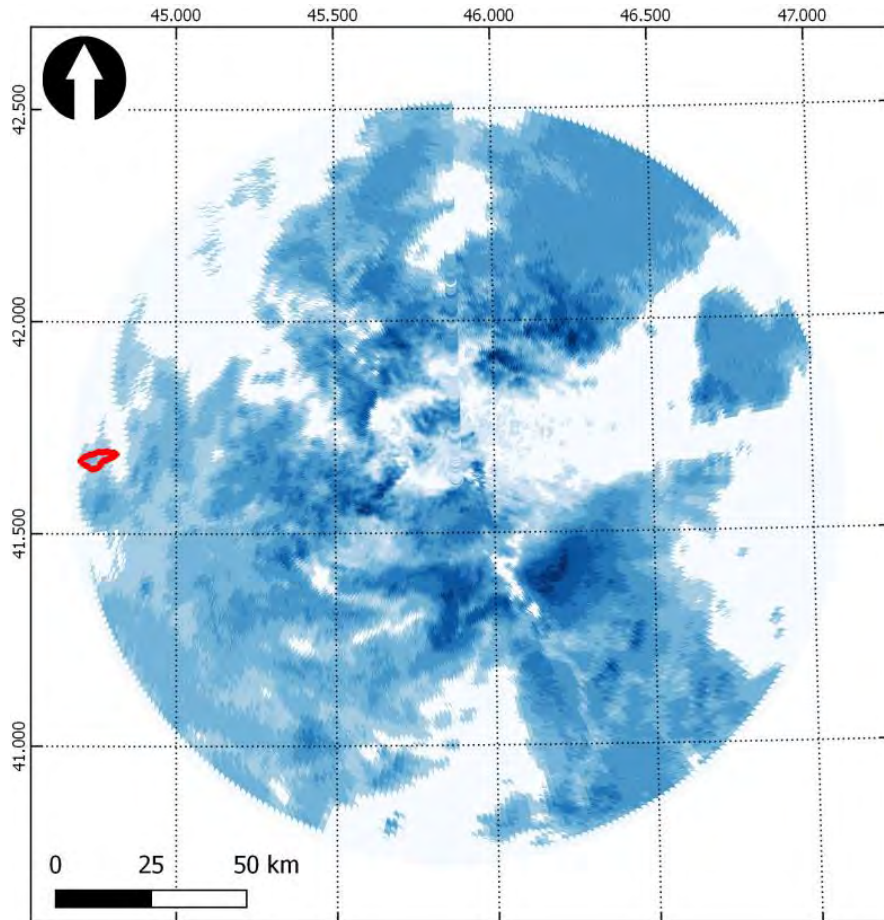

- Rainbow© data format readable with WRADLIB Python library
- Selecting 2016 rain events
- Inclination selection, reflectivity to rainfall, attenuation correction, clutter removal...
- Georeferencing and calculation of average rainfall intensity in the catchment

# Comparison gauge and radar



Date	Kojori gage	Radar	Notes
	mm/d		
07.06.2016	18.3	48.2	
08.06.2016	3.4	4.0	
09.06.2016	12.0	56.2	
10.06.2016	18.6	18.4	
01.07.2016	32.8	1.0	Radar data not complete
21.09.2016	9.8	16.9	
22.09.2016	0.0	10.6	
23.09.2016	51.4	45.9	
24.09.2016	6.6	4.7	
16.11.2016	5.0	33.6	Major rainfall occurred around midnight
17.11.2016	35.1	21.5	

- Some events are **well represented**, others **not**
- Without calibration (fitting to gauges) of radar data, radar cannot be directly used for modelling

# Radar data disaggregation options

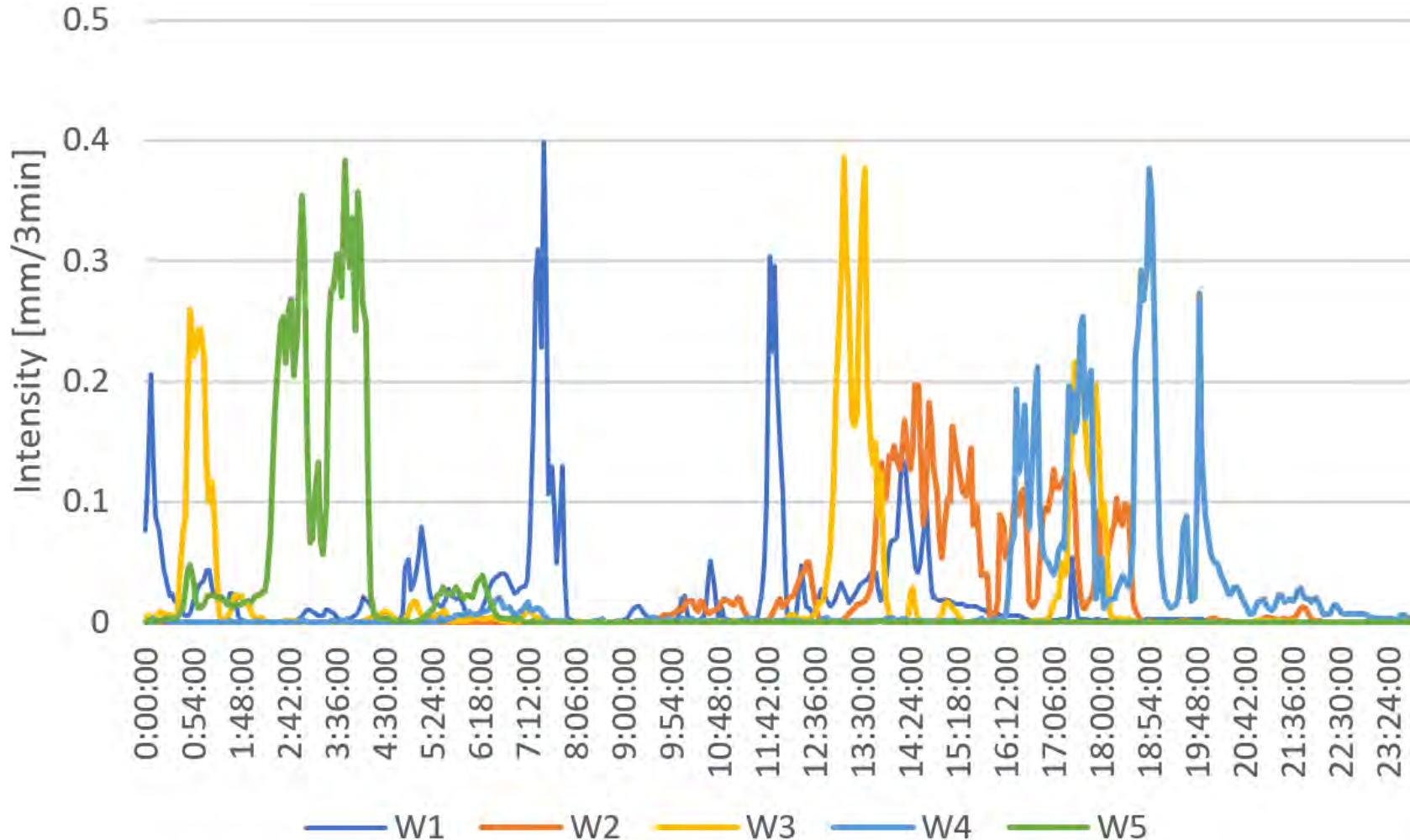

- Events scaled to 10mm/day
- Each option is equally (un)likely to represent a possible distribution of daily rainfall in the Leghtvakhevi

# Discharge data Vere

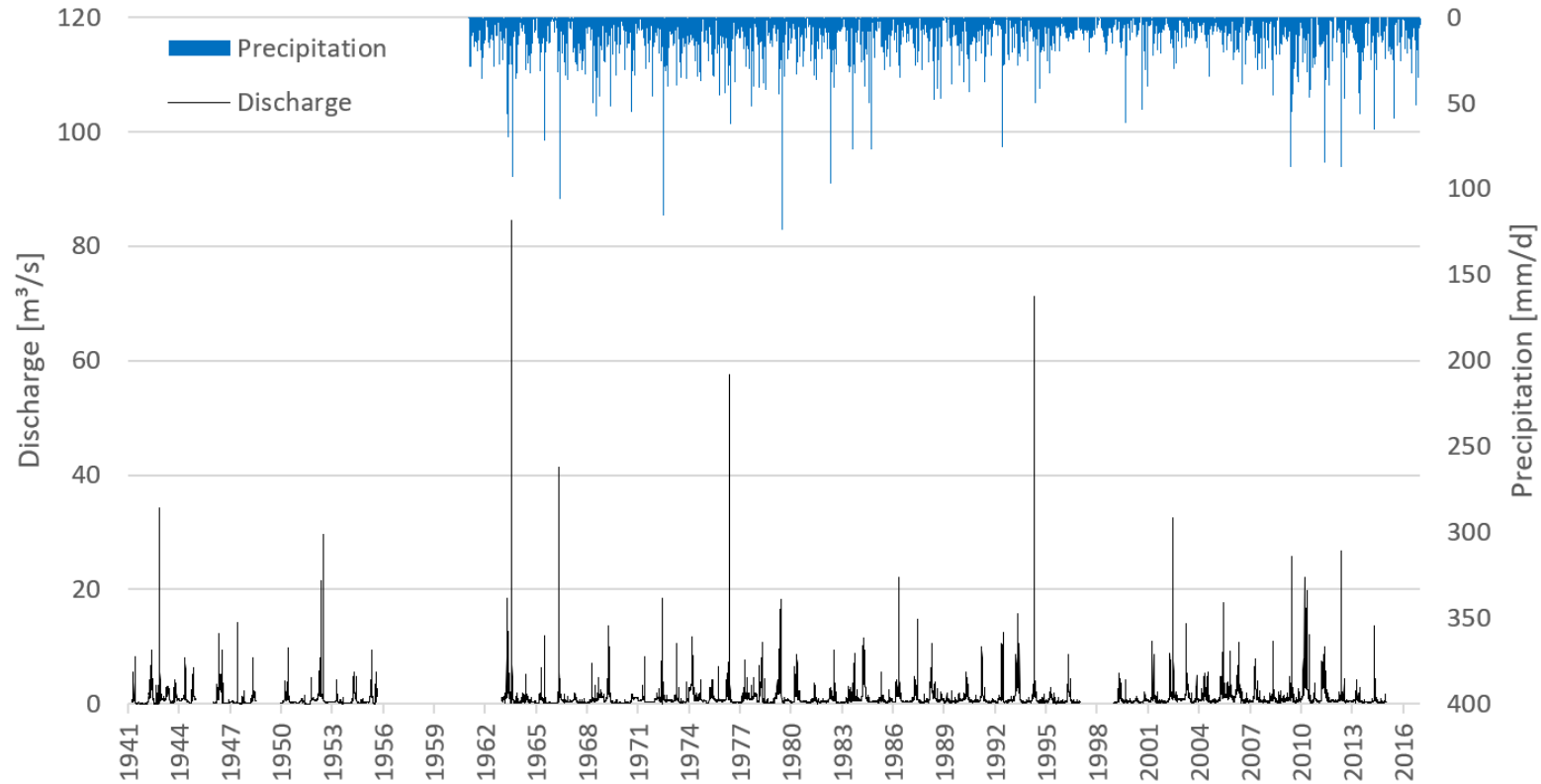

- Discrepancies with hydrological reports exist:  
1972: 155.3m<sup>3</sup>/s  
1960: 259m<sup>3</sup>/s
- No significant impact of groundwater or snowmelt processes

„If **time steps** are chosen **too long**, the **peak runoff** rate is systematically **too small**“

# Problems arising from daily discharge observations in small catchments



- Daily vs subdaily observed discharge => Problem in assessing model result

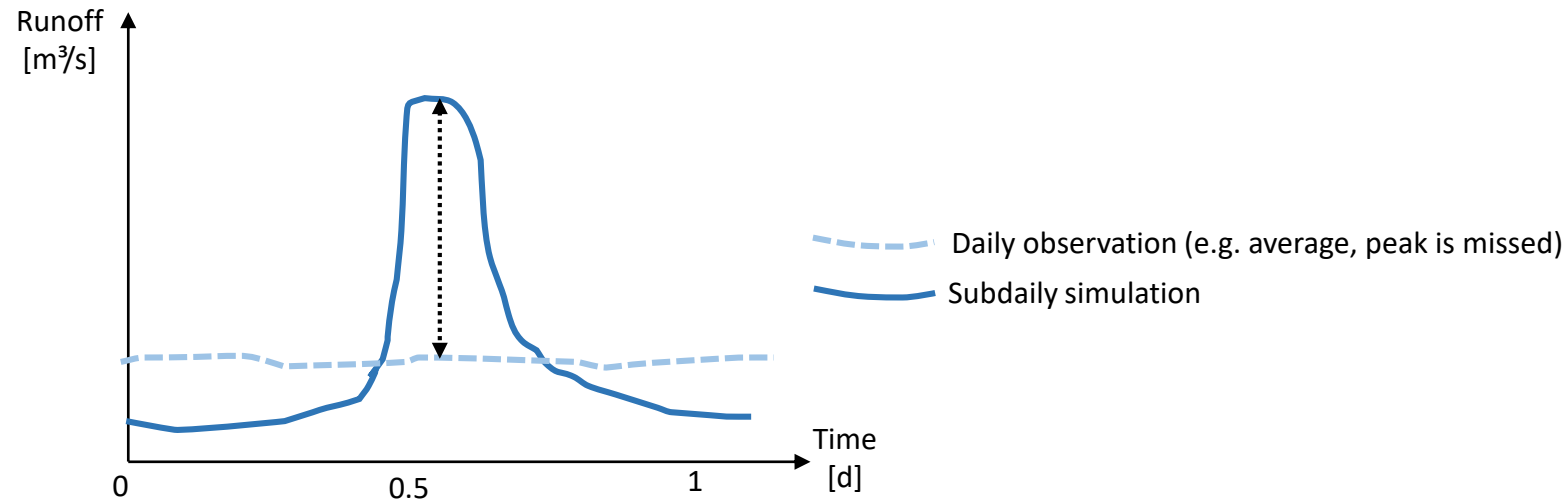

- ➔ We need to carry out subdaily discharge observations to calibrate the model to peak flows
- ➔ Calibration only possible to runoff volumes in the Vere

# Content



- Why hydrological modelling?
- Task definition and objectives
- Essential theoretical background (short)
- Which model and approach is suitable?
- Available data and its quality
- Model calibration, sensitivity analysis and uncertainty
- Design events for baseline and climate change
- Discussion

# HEC-HMS model of Vere and Leghtvakhevi

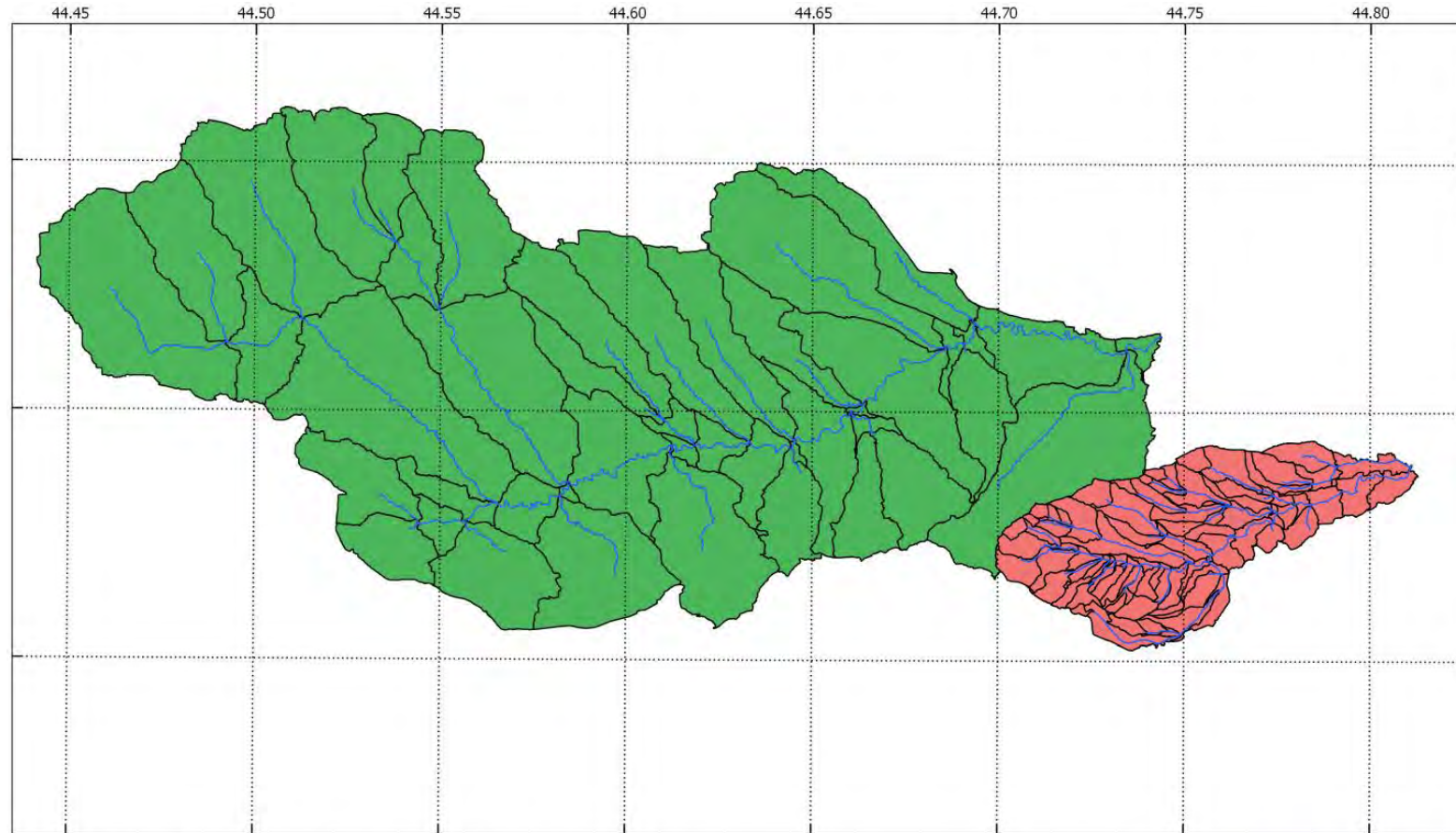

Leghtvakhevi and Vere - Catchment delineation

- Stream network
- Vere Subbasins
- Leghtvakhevi Subbasins

0 3 6 km

Coordinate System:  
WGS 1984 UTM Zone 38N  
Projection: Transverse Mercator  
Grid: WGS84, Decimal Degrees



www.hydroc.de

- Spatial discretization (0.2km<sup>2</sup> initiates a stream)
- Hydraulic model input points in Leghtvakhevi

# HEC-HMS model schematics

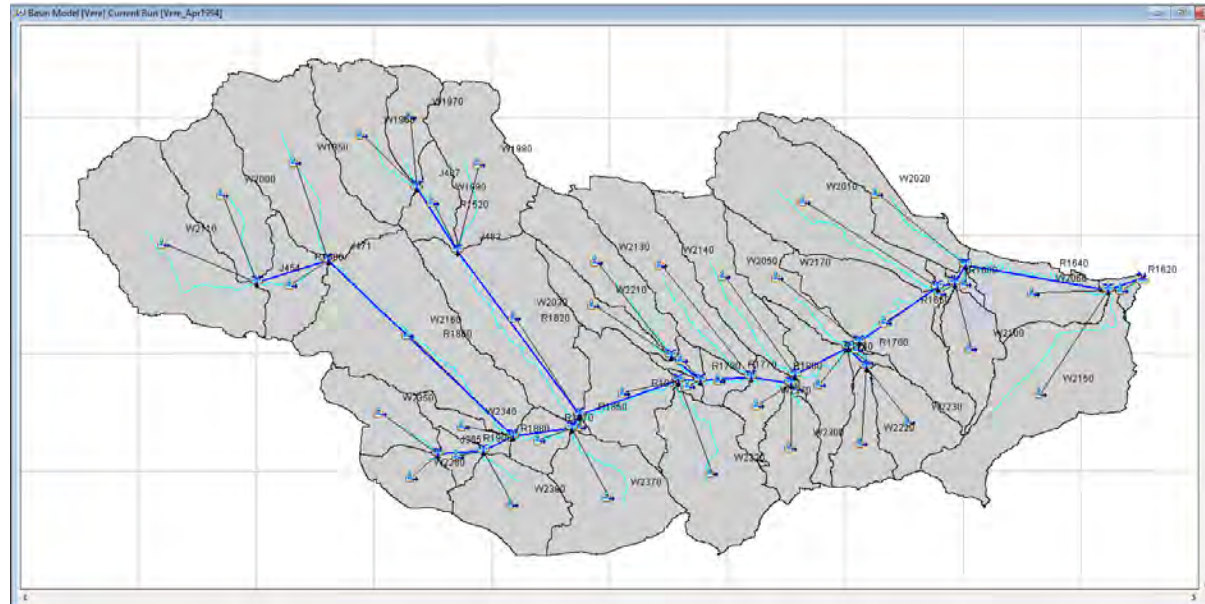

Vere

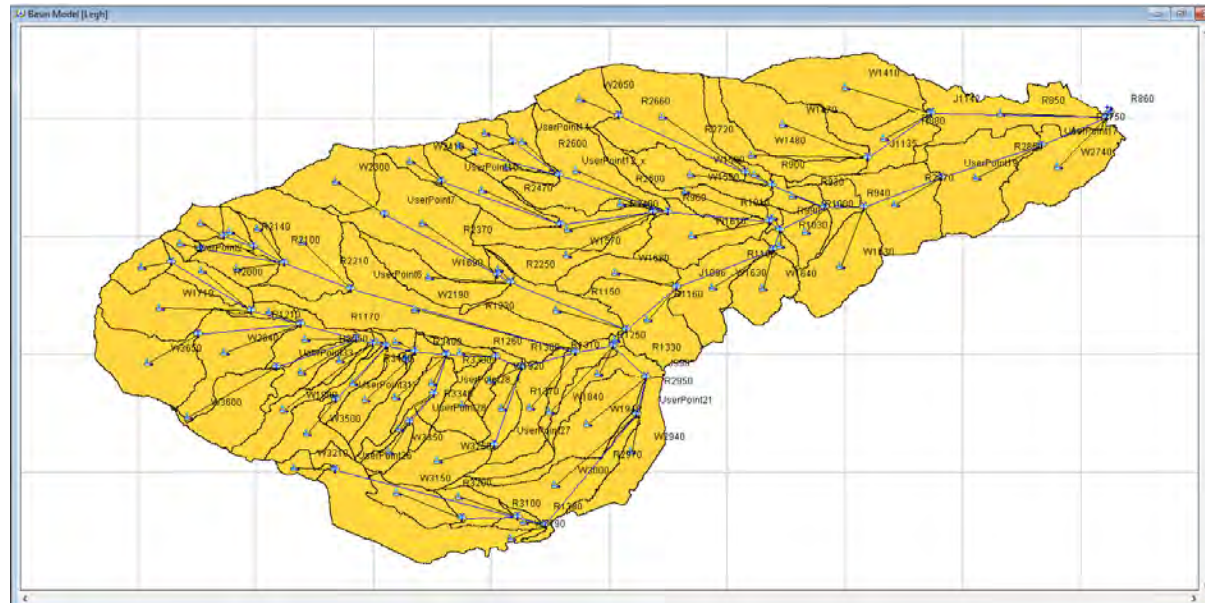

Leghtvakhevi

# HEC-HMS model algorithms



Process	Algorithms Leghtvakhevi	Algorithms Vere
Canopy storage	Simple Canopy	Simple Canopy
Surface depression storage	Simple Surface	Simple Surface
Infiltration (loss) method	Initial Constant Loss	Initial Constant Loss
Transformation method	Modified Clark	None
Baseflow	Constant Monthly	Constant Monthly
River Routing	Kinematic Wave	None
Channel losses/gain	None	None
Precipitation	Specified Hyetograph	Specified Hyetograph
Evapotranspiration	None	None
Snowmelt	None	None

# HEC-HMS Vere calibration



Event	Observed	W1 def.	W2 def.	W3 def.	W4 def.	W5 def.	W5 calib.
	Volume [Mill m <sup>3</sup> ]						
Aug-63	14.73	16.07	18.96	20.75	19.07	22.37	24.43
May-76	12.29	11.94	14.19	15.93	14.70	16.64	19.43
Apr-94	<b>15.43</b>	9.11	10.91	12.47	11.42	13.48	<b>15.16</b>

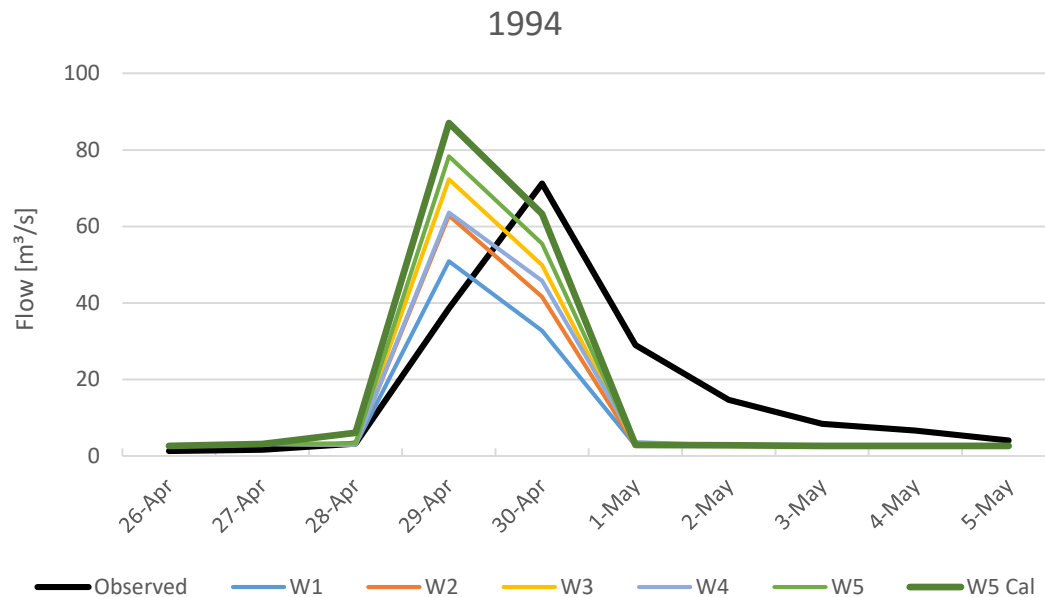

- ➔ Reduction of soil infiltration capacity ( $k_{sat}$ ) by 50% in both Vere and Legthvakhevi
- ➔ Selected the most conservative options: event 1994 and radar option W5

# Leghtvakhevi sensitivity analysis: Different radar disaggregation options

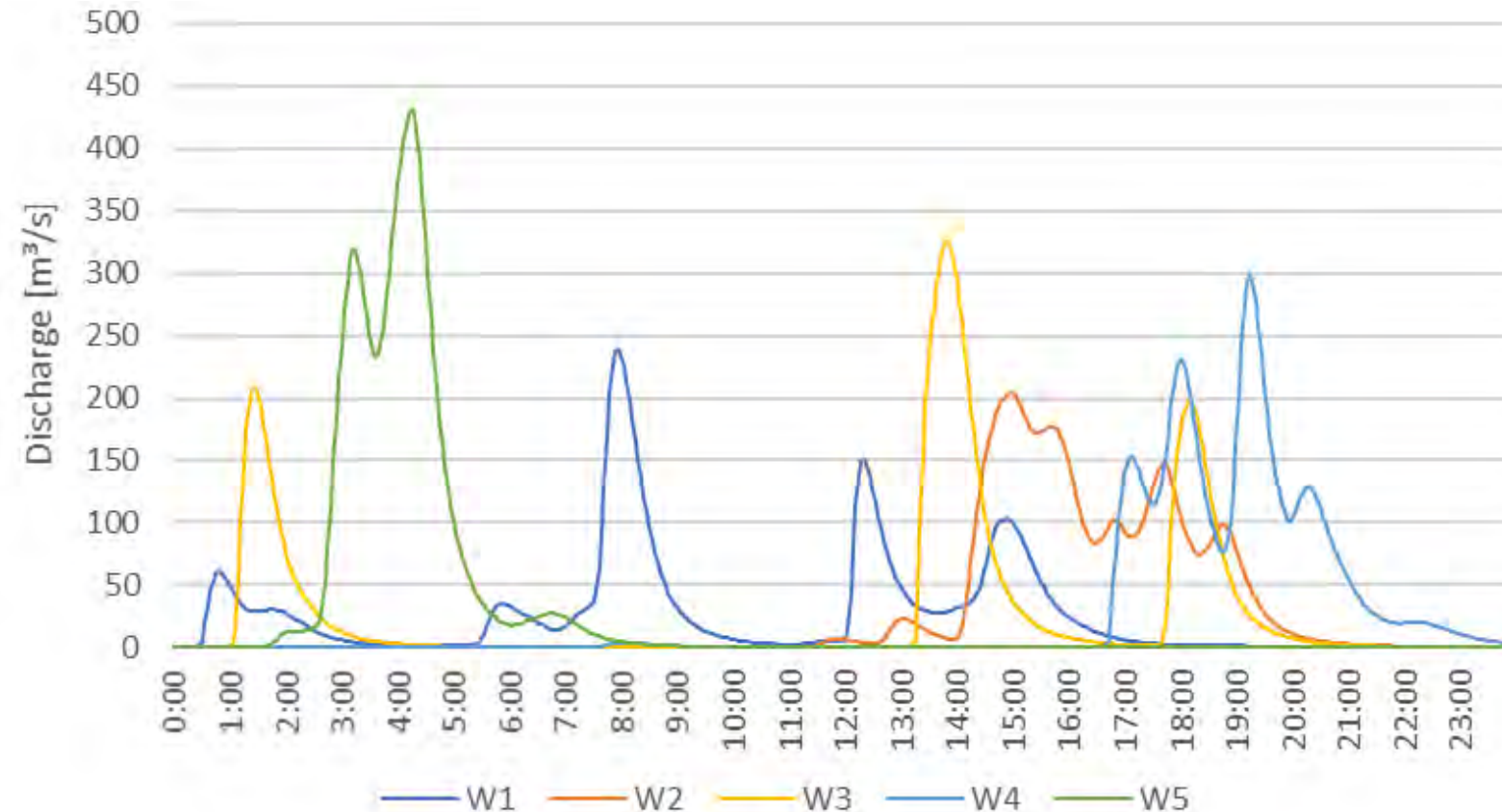

- Discharge (100yr RP) is very sensitive to the different distributions

➔ Use the most conservative option (W5)

	W1	W2	W3	W4	W5
Peak Flow [m³/s]	239	204	325	298	<b>431</b>

# Leghtvakhevi sensitivity analysis: Transformation parameters

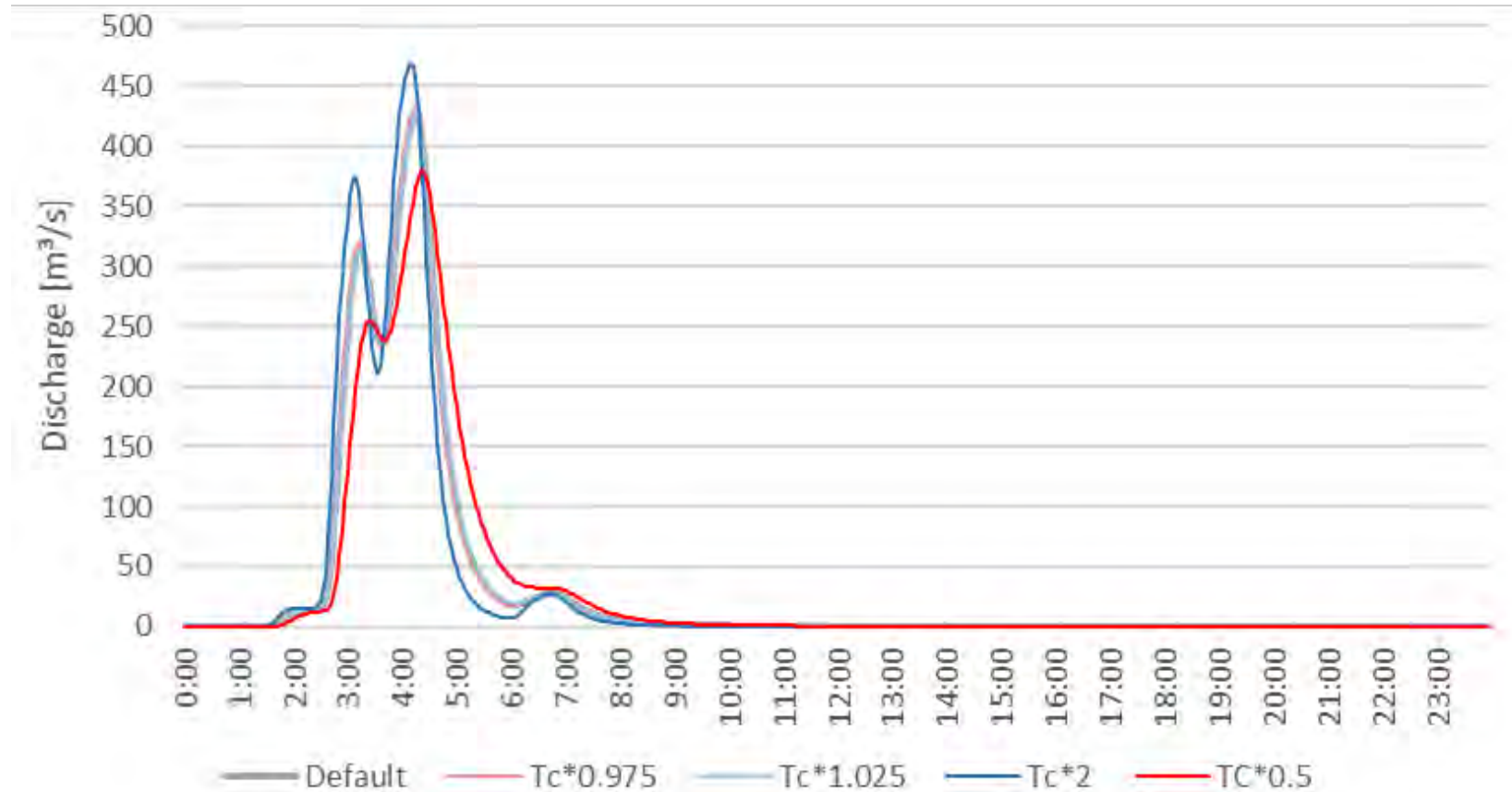

- Clark Transform method uses Time of Concentration
- Not extremely sensitive in reasonable ranges

	Tc*0.975	Tc*1.025	Tc*2	TC*0.5
Peak flow change [%]	0.4%	-0.5%	8.9%	-11.9%

# Leghtvakhevi sensitivity analysis: Routing parameters



	Width times 0.5	Width times 2	Side Slope = 1	Side Slope = 4	Mannings n = 0.03	Mannings n = 0.05
Peak flow change [%]	-0.1%	0.0%	+ 0.3%	-1.0%	+ 0.7%	-0.4%

- Not sensitive on peak flow magnitude

# Content



- Why hydrological modelling?
- Task definition and objectives
- Essential theoretical background (short)
- Which model and approach is suitable?
- Available data and its quality
- Model calibration, sensitivity analysis and uncertainty
- Design events for baseline and climate change
- Discussion

# Design events baseline and climate change



Return Period	Precipitation [mm/d]	
	Baseline	Scenario RCP8.5 - 2070
RP5	66.95	167.86
RP25	105.96	199.91
RP50	124.89	204.98
RP100	145.02	208.95
RP500	199.91	212.94

- Extrapolation of long-term daily precipitation data using probability distributions
- Climate change impacts from all available climate models
- Strong projected increase in the lower RPs

# Calculated discharges of design events



Baseline

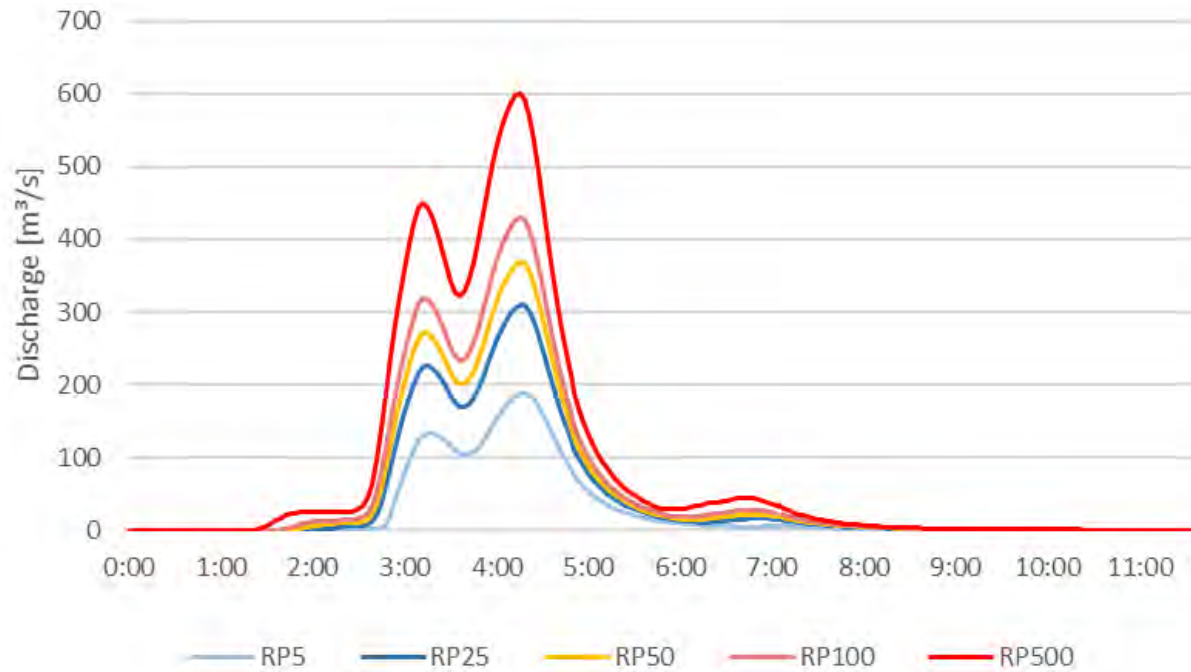

Climate Change

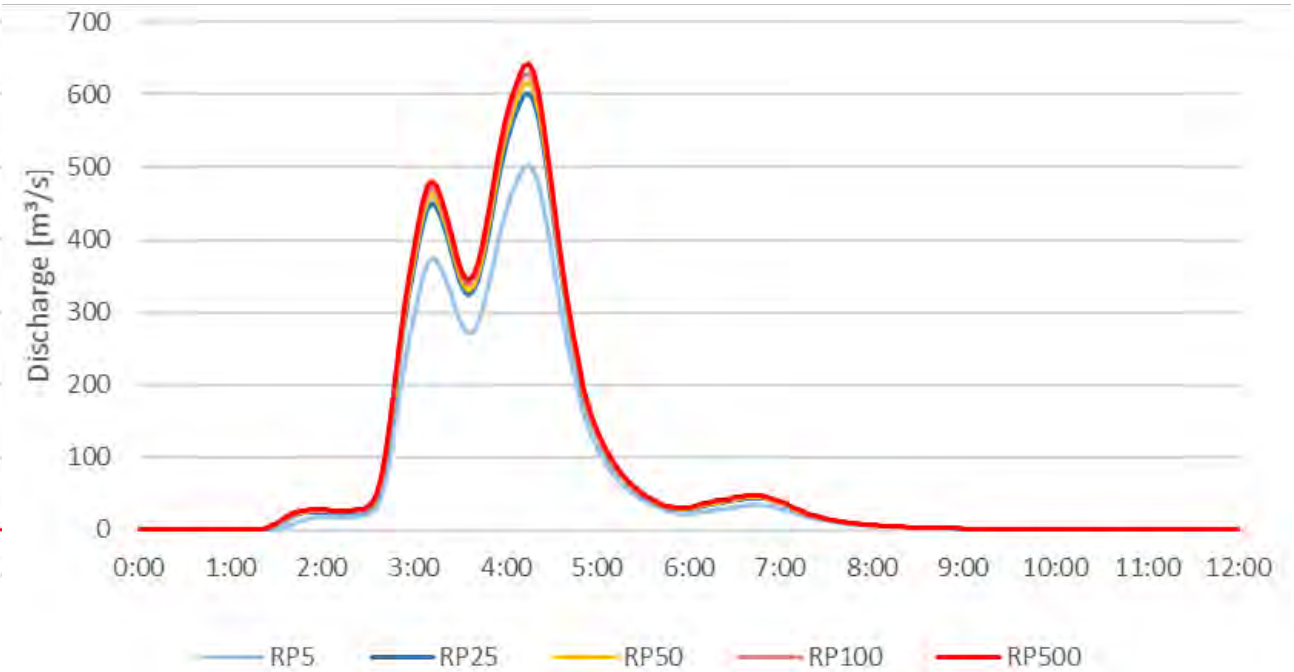

Peak flows [m <sup>3</sup> /s]	RP5	RP25	RP50	RP100	RP500
Baseline	189	310	369	431	601
RCP8.5 2070	502	601	617	629	642

# How does this compare to available flash flood data?



Peak flows [m <sup>3</sup> /s]	RP5	RP25	RP50	RP100	RP500
Baseline	189	310	369	431	601
RCP8.5 2070	502	601	617	629	642

7.9 – 26.8 m<sup>3</sup>/s/km<sup>2</sup>

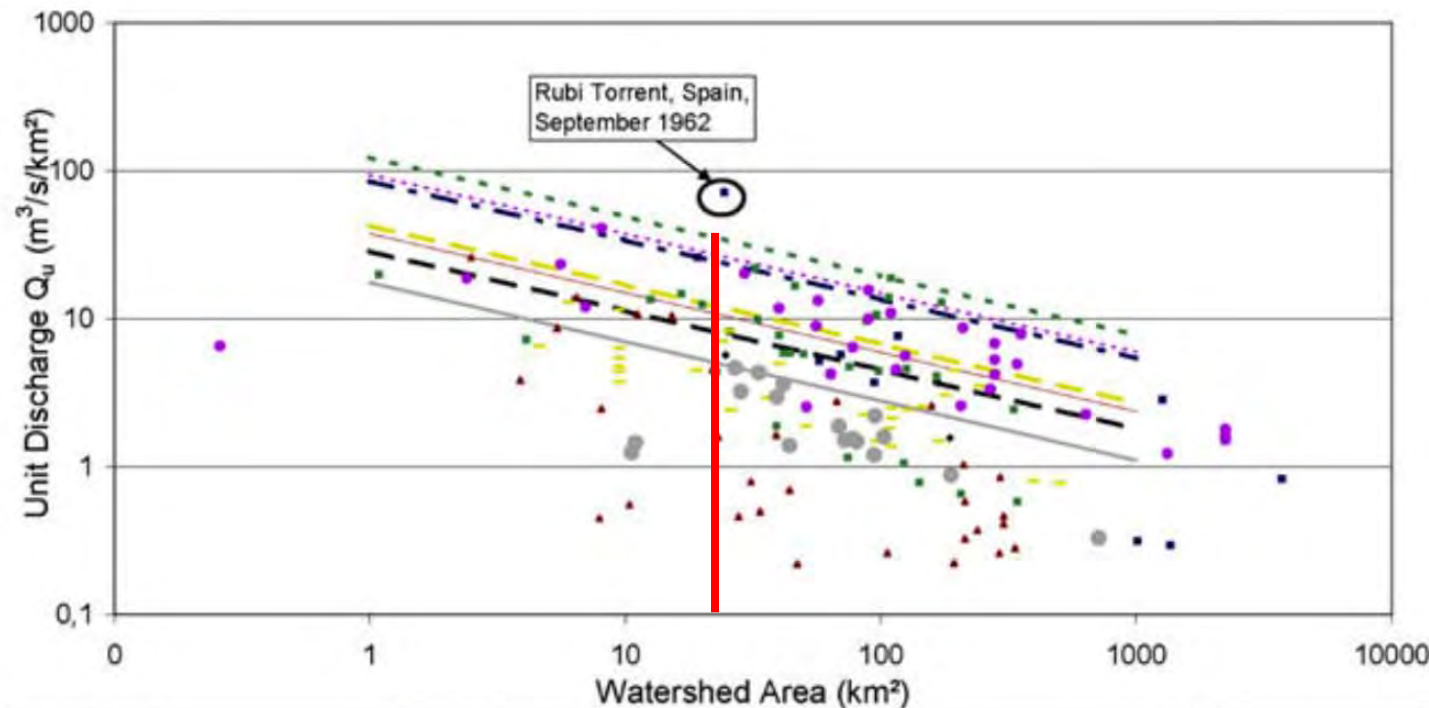

The simulations are realistic when being compared to observed data from regions in Europe prone to flash-flooding

Gaume et al. (2009)  
Journal of Hydrology

<http://www.hydrate.tesaf.unipd.it/WareHouse/EuropeanDataCenter/>

# Content



- Why hydrological modelling?
- Task definition and objectives
- Essential theoretical background (short)
- Which model and approach is suitable?
- Available data and its quality
- Model calibration, sensitivity analysis and uncertainty
- Design events for baseline and climate change
- Discussion

# Outlook



- Transfer HEC-HMS discharges at all subbasins to HEC-RAS to obtain inundation maps
- Starting point to refine simulations if new data becomes available
- Continuous model (e.g. for early warning) requires additional (ET, snowmelt) and different model algorithms selection (soil moisture accounting, linear baseflow)

# Summary



- Modelling efforts were severely hindered by the temporal data availability
- Extensive work was done to obtain sub-daily, recent precipitation time series
- A second HEC-HMS model was built in the Vere to carry out basic calibration
- Careful evaluation of model parameters and sensitivity checks was carried out
- First estimation of design discharges in the Leghtvakhevi are subject to a wide spread
- Increasing discharges are projected under climate change especially for lower RPs

# Limitations and their implications for decision-making



- Model building is always a spatial and temporal simplification process which introduces uncertainties in the results - these can be reduced if proper calibration of parameters is possible
- Highest uncertainties in the simulations arise from
  1. unknown distribution of sub-daily rainfall distribution
  2. unknown typical antecedent moisture conditions
  3. future climate change projections
- Conservative selections were made, indicating that the results are more likely to overestimate 'true' discharges than to underestimate
- Results are in realistic ranges when being compared to other flash flood data

# Recommendations



- Long-term observation of sub-daily rainfall to:
  1. obtain the likely sub-daily distribution of extreme storm events, calibrate radar data
  3. obtain information on typical antecedent moisture conditions of these storms
- Long-term observation of sub-daily discharge time series
- Record water levels and damages to infrastructure in the gorge
- Update the model once more reliable data are available
- For establishing an early warning system, reliable weather forecast and real-time radar data processing is most important

# Further discussion



- Questions to the shown presentation?
- What problems exist in terms of catchment management and decision-making?
- What are short and long-term plans and capabilities of hydro-meteorological monitoring in Tbilisi?
- What additional modelling skills would you want to establish in your organization?
- What are regions and catchments of particular interest?
- What are problems/gaps in those regions?

Dr. Jens Kiesel  
jkiesel@hydroc.de

Thank you for your valuable attention!

HYDROC GmbH  
Siegum 4, 24960 Siegum, Germany  
Managing Director: Dr. Georg Petersen

14.05.2018 – 25.05.2018  
at Ilias State University

# Assessment of Suitable Flood Mitigation Measures in Tbilisi, Georgia

- Hydrologic Modelling Training -



Dr. Jens Kiesel  
jkiesel@hydroc.de



May 2018

## Session 2

- Daily precipitation data processing -



Dr. Jens Kiesel  
[jkiesel@hydroc.de](mailto:jkiesel@hydroc.de)



# Content



- Questions from yesterday?
- Problem statement
- What you will learn in this session
- Hands-on work

# Available precipitation datasets



Description	Resolution	Source	Year
Daily precipitation data	Gauges <b>Kojori</b> , Tbilisi Airport, Vashlijvari	Supplied by NEA	Data ends in <b>2005</b> , 2016
Radar precipitation	3min temporal for four storm events	Supplied by NEA	<b>2016</b>

## ➔ Significant data gaps

- Daily precipitation in Kojori ends in 2005
- No sub-daily precipitation gauges
- To use the radar data, we need to extrapolate Kojori time series up to 2016

# Kojori daily precipitation data extension

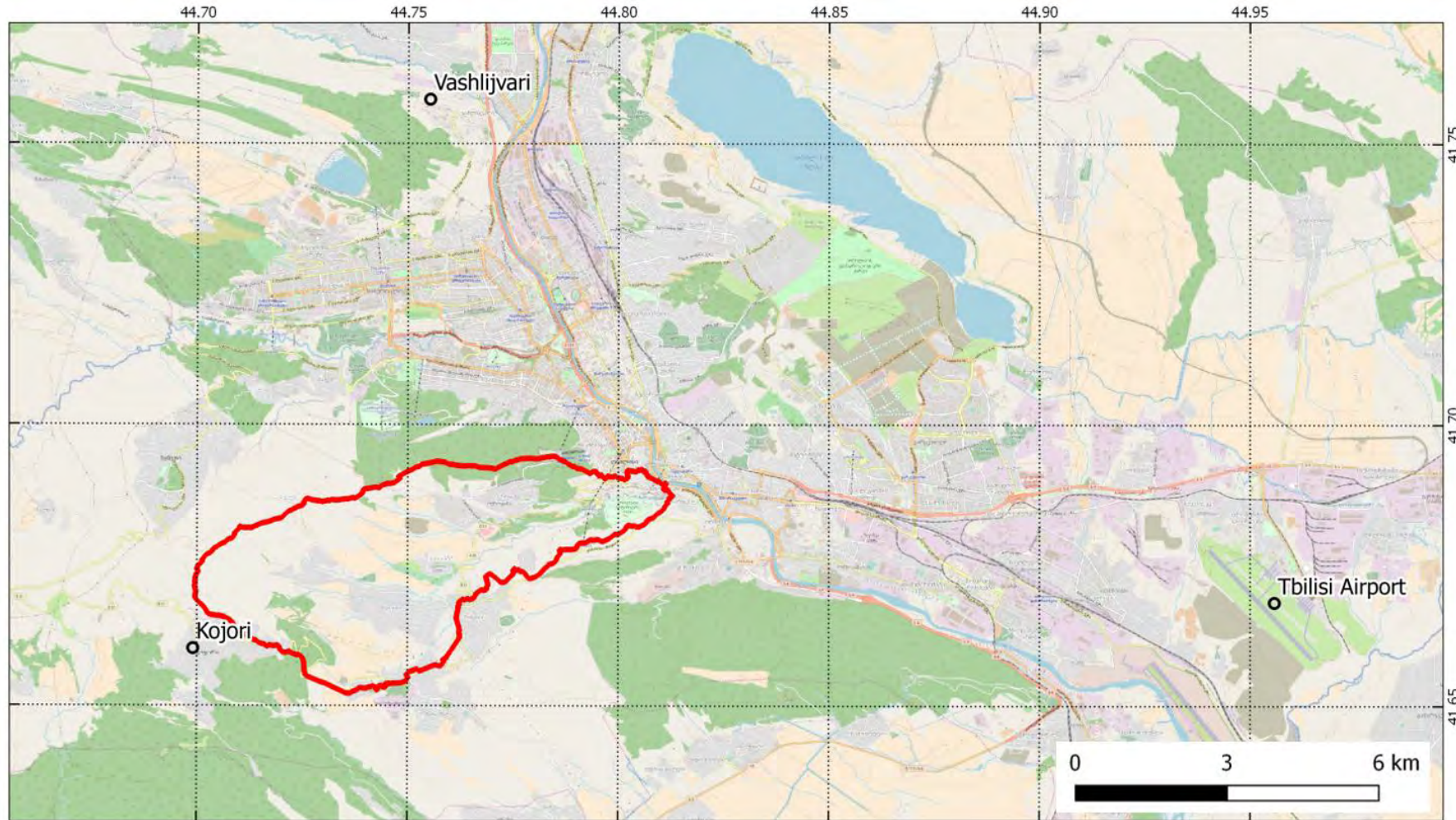

Station	Elevation	Begin	End
Vashlijvari	427	1961	<b>2016</b>
Airport	462	1980	2010
Kojori	1381	1961	<b>2005</b>

○ Location of precipitation stations  
□ Leghvtakhevi Catchment

Background: Open Street Map

# What you will learn in this session



- Precipitation data analysis and processing in Excel or OpenOffice
  - select time series to be used to fill Kojori
  - extrapolate the time series through linear regression
- Calculation of precipitation return period intervals
  - time of concentration of both Leghtvakhevi and Vere are <1d
  - design events are based on the 1-day maximum annual events
  - using extreme value statistics to extrapolate probabilities

# Hands-on work – Part 1



## **Precipitation data analysis and processing in Excel or OpenOffice**

Open the file „*MeteoData\_DLY.xlsx*“ in the folder „... \Day02\_Daily\_PCP\_Processing\“

Follow the explanation in the Handout

# Extreme value statistics I



## Definition of precipitation return periods: Extrapolation of extreme events

- Return period = Recurrence interval
- Data processing of 1d-maximum annual precipitation:
  - representative, no systematic or random errors, normal distributed, no outliers
- Fitting of a probability distribution to the histogram of precipitation values

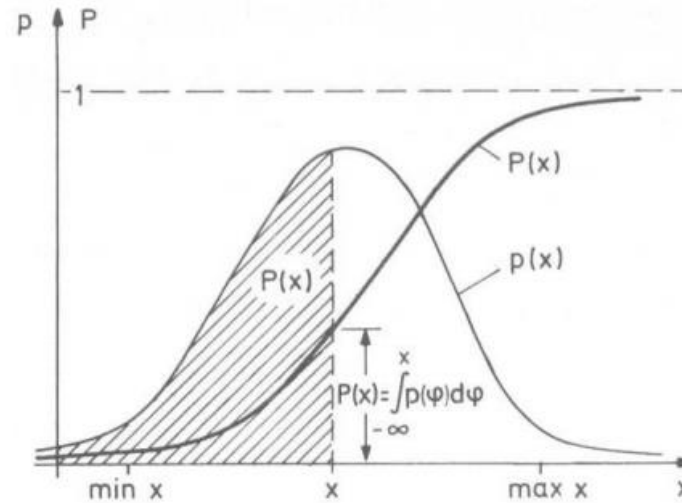
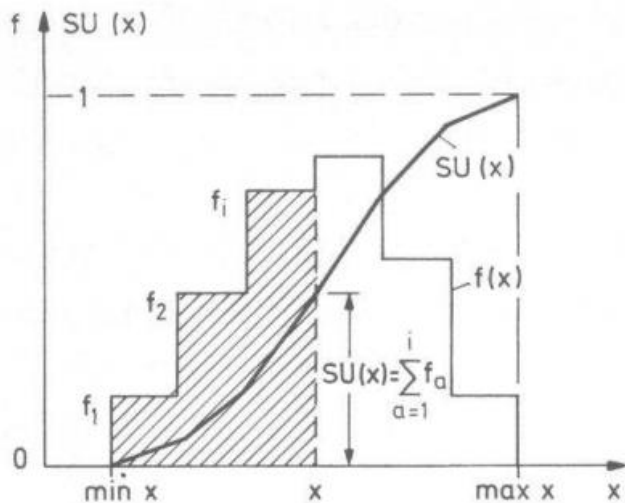

# Extreme value statistics II

## Definition of precipitation return periods: Extrapolation of extreme events

- Checking which distribution follows the data best

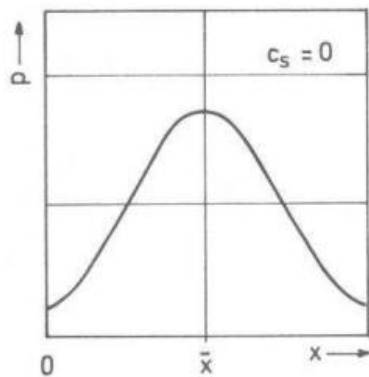

(a) Gauß

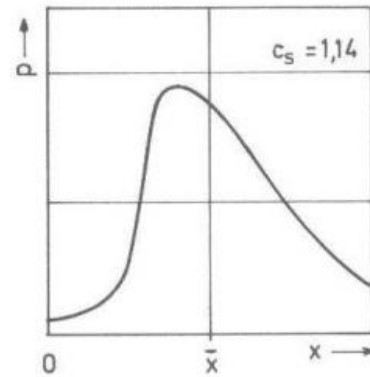

(b) Gumbel

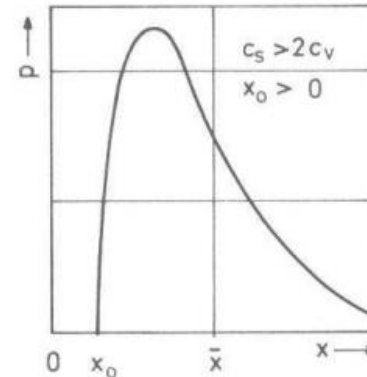

(c) Pearson III

commonly used distributions  
in hydrology

- Extrapolation to extreme events ideally only to 2 to 3 times the original time series length

# Hands-on work – Part 2



## **Return period (recurrence interval) estimation of precipitation**

Open the file „*ReturnPeriod.R*“ in the folder „...*\Software\Executables\_and\_Scripts\*“ in R Studio and the .xlsx file prepared under Part 1

Follow the explanation in the Handout

14.05.2018 – 25.05.2018  
at Ilias State University

# Assessment of Suitable Flood Mitigation Measures in Tbilisi, Georgia

- Hydrologic Modelling Training -



Dr. Jens Kiesel  
jkiesel@hydroc.de



May 2018

## Session 3

- Sub-daily precipitation data processing -



Dr. Jens Kiesel  
jkiesel@hydroc.de



# Content



- Questions from yesterday?
- Problem statement
- What you will learn in this session
- Hands-on work

# Problems arising from daily precipitation time steps



- **Daily** vs **subdaily** observed precipitation => Problem in simulation of runoff peak

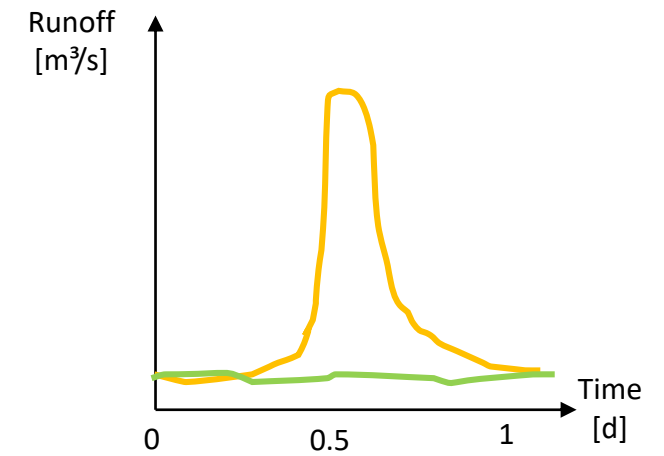
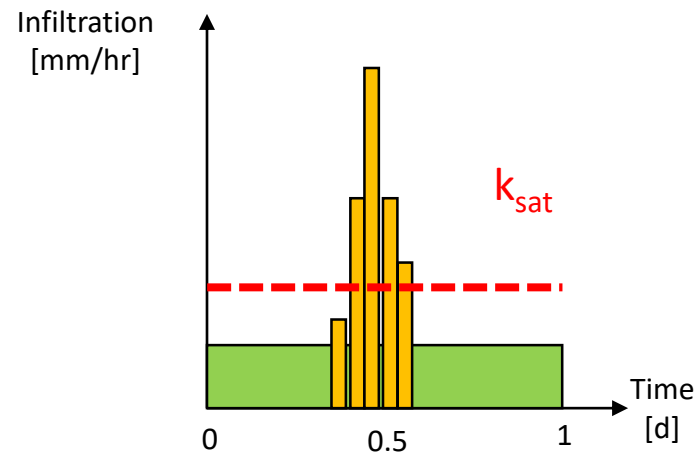
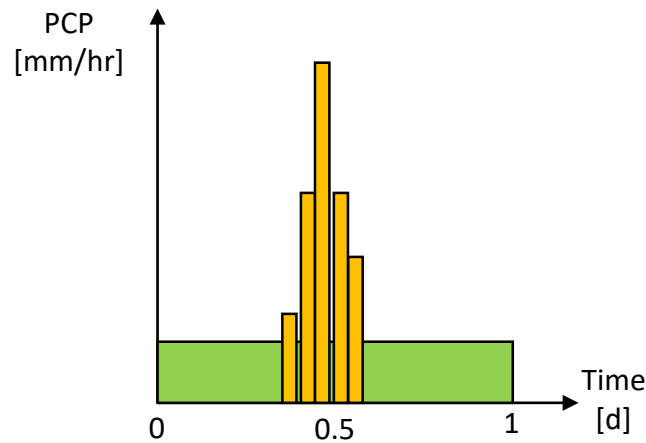

➔ We need to disaggregate (increase the resolution) of the daily precipitation time steps

# Utilizing data from rainfall radar

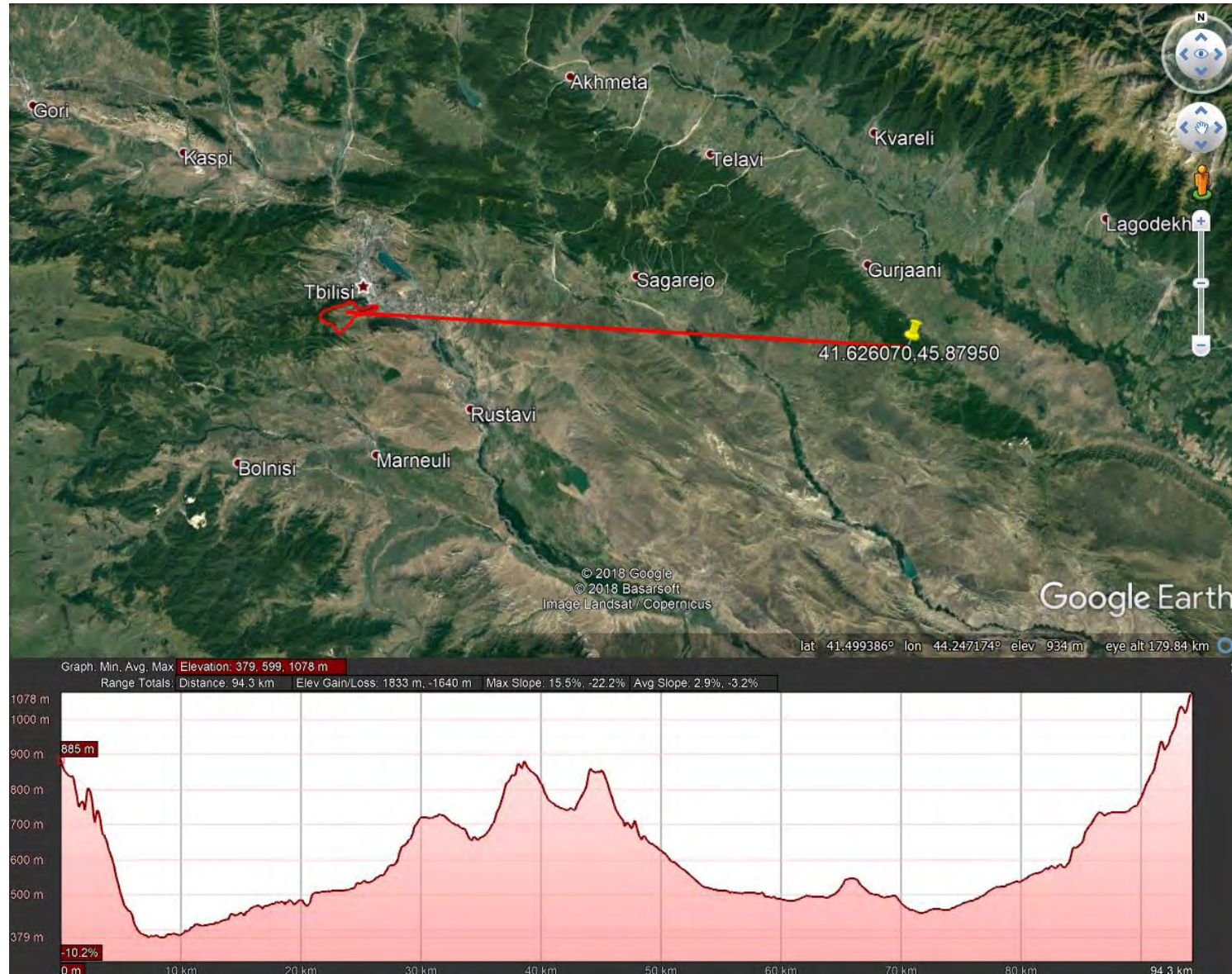

- Rainfall radar about 100km east of Tbilisi
- 3min intervall
- Since 2016
- Example reflectivity:

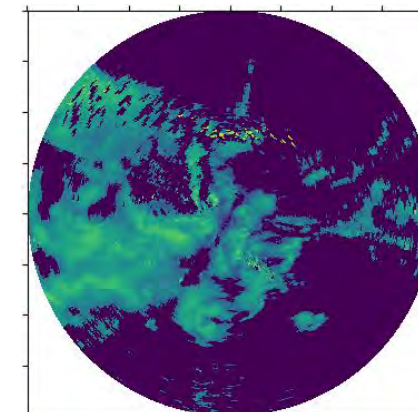

# Extracting data for Leghtvakhevi

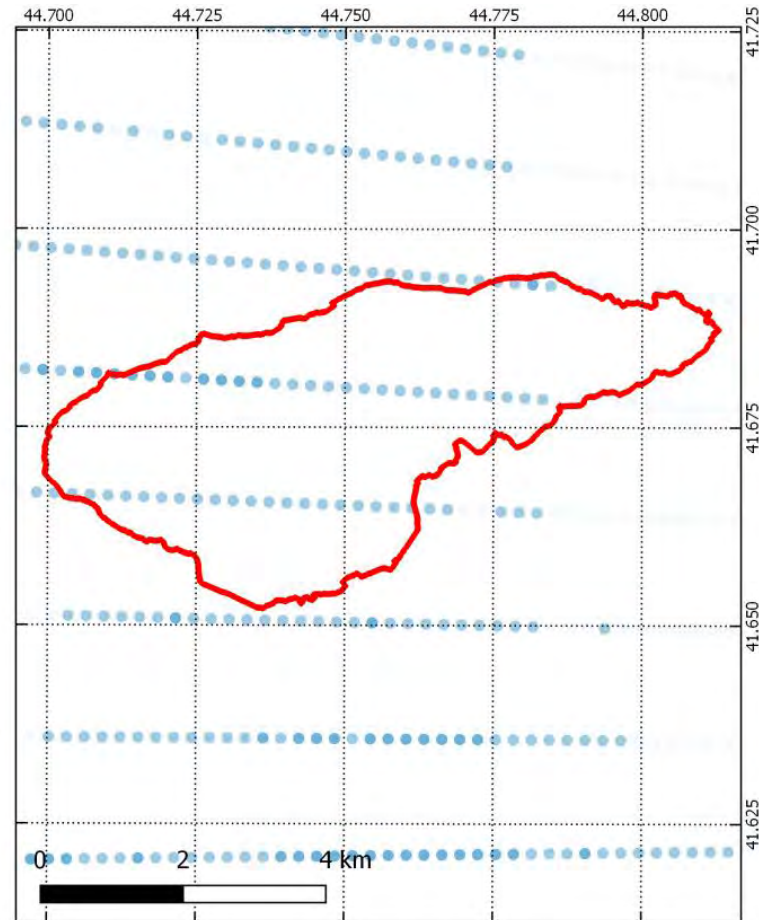
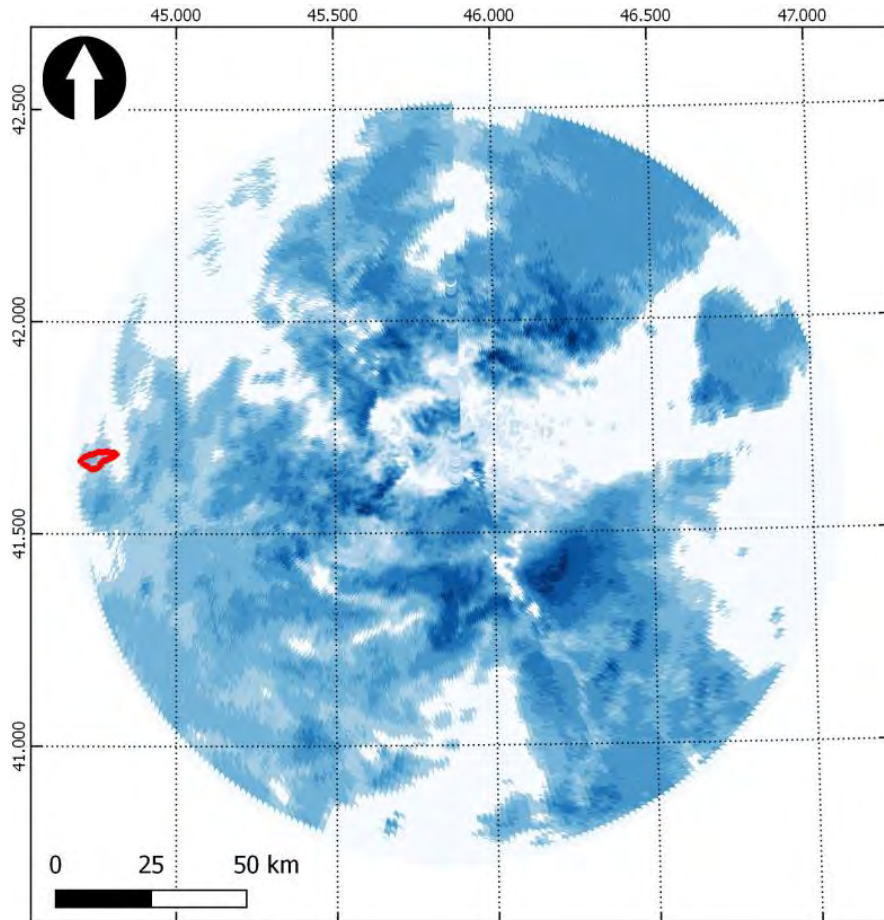

- Selection of 2016 rain events
- Inclination selection, reflectivity to rainfall, attenuation correction, clutter removal...
- Georeferencing and calculation of average rainfall intensity in the catchment

# Comparison gauge and radar



Date	Kojori gage	Radar	Notes
	mm/d		
07.06.2016	18.3	48.2	
08.06.2016	3.4	4.0	
09.06.2016	12.0	56.2	
10.06.2016	18.6	18.4	
01.07.2016	32.8	1.0	Radar data not complete
21.09.2016	9.8	16.9	
22.09.2016	0.0	10.6	
23.09.2016	51.4	45.9	
24.09.2016	6.6	4.7	
16.11.2016	5.0	33.6	Major rainfall occurred around midnight
17.11.2016	35.1	21.5	

- Some events are **well represented**, others **not**
- Without calibration (fitting to gauges) of radar data, radar cannot be directly used for modelling

# Radar data disaggregation options

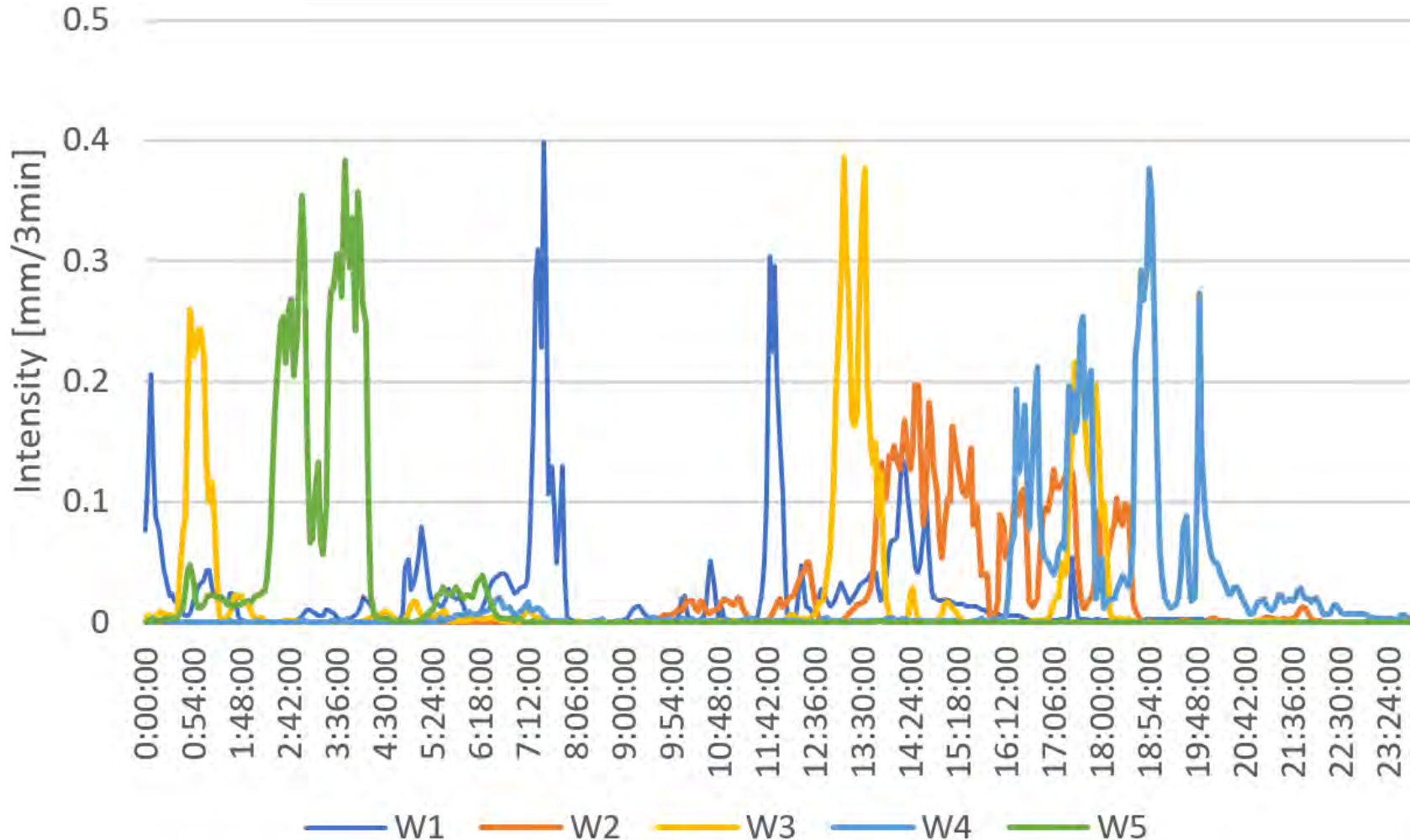

- Events scaled to 10mm/day
- Each option is equally (un)likely to represent a possible distribution of daily rainfall in the Leghtvakhevi

# What you will learn in this session



- Radar data extraction
  - extraction of time series
  - extraction of spatial plots
- Radar data analysis
  - comparing different extraction settings
  - comparing different events
  - comparing different locations
- Disaggregation of the 100yr RP value using radar data

# Radar data processing is complex: Theoretical background



- Radar meteorology principles and practice

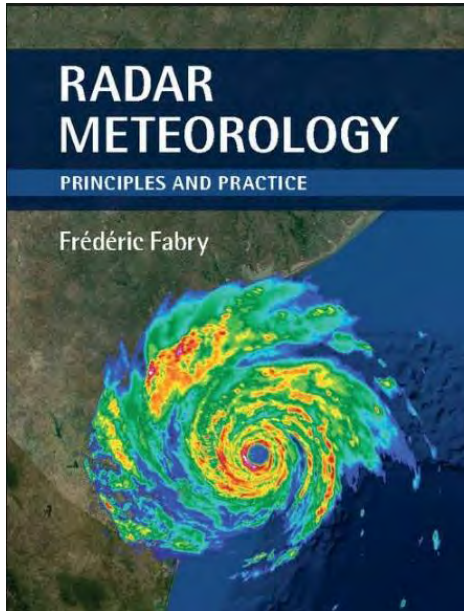

- Open source radar data processing:  
<http://docs.wradlib.org/en/latest/>

# Brief background info on weather radar



- **RA**dio **D**etection **A**nd **R**anging (1940s US Navy)
- Transmission and receiving of radio- or microwaves

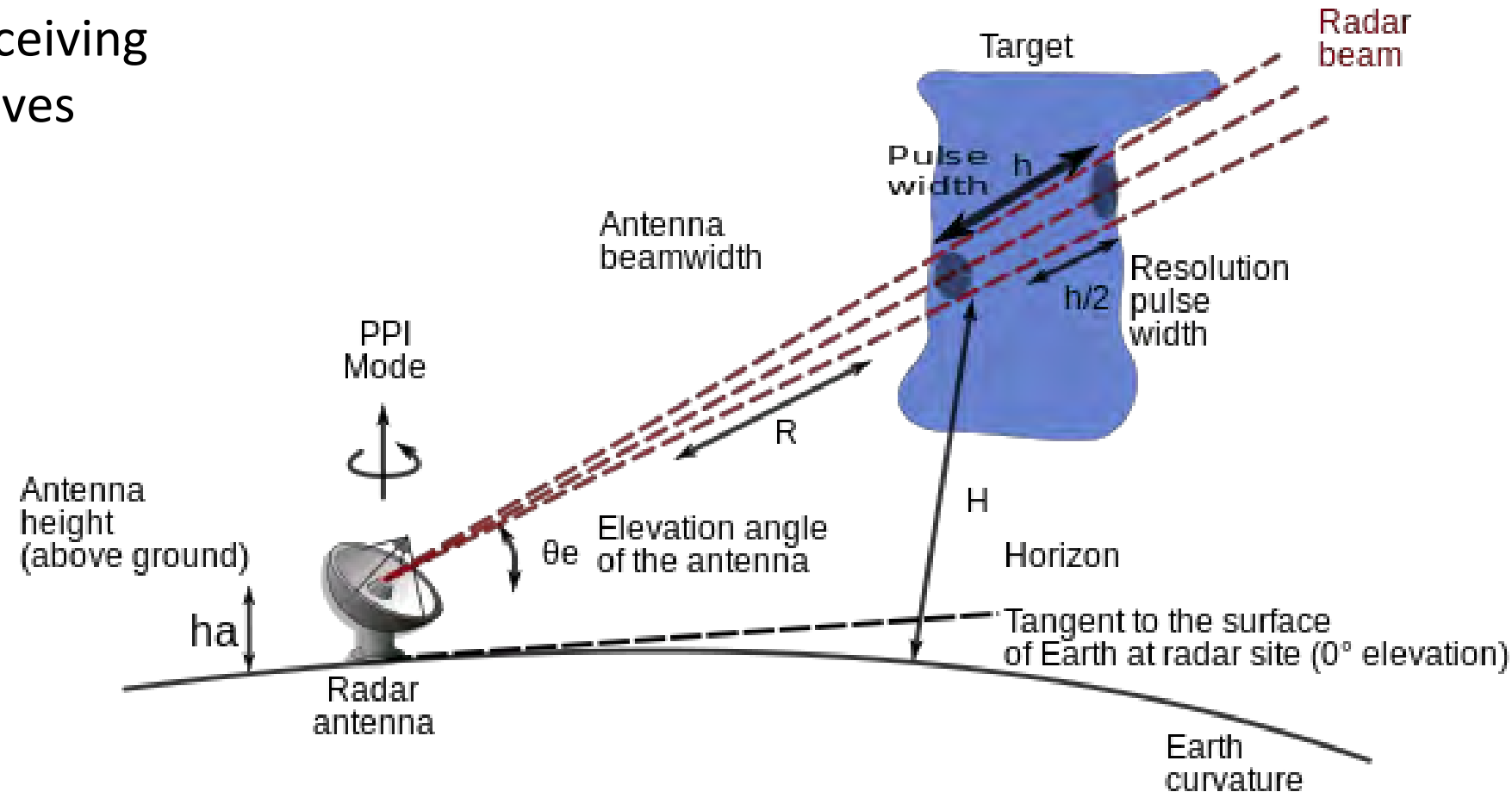

# Brief background info on weather radar



- Weather radar can locate precipitation, its motion, and its type (rain, snow, hail, ...)
- The return scatter of the waves (reflectivity) are measured in decibel (dBZ)
  - magenta: 65 dBZ (extremely heavy precipitation, possible hail)
  - red: 52 dBZ
  - yellow: 36 dBZ
  - green: 20 dBZ (light precipitation)
- Workflow to process radar data:  
[http://docs.wradlib.org/en/latest/notebooks/basics/wradlib\\_workflow.html](http://docs.wradlib.org/en/latest/notebooks/basics/wradlib_workflow.html)

# Hands-on work – Part 1



**Radar data extraction using „*extract\_radar\_rainbow\_Compiled.exe*“**

Open the folder „... \Day02\_Daily\_PCP\_Processing\“

Follow the explanation in the Handout

# Hands-on work – Part 2



## **Comparison of different radar extraction options**

Follow the explanation in the Handout

14.05.2018 – 25.05.2018  
at Ilias State University

# Assessment of Suitable Flood Mitigation Measures in Tbilisi, Georgia

- Hydrologic Modelling Training -



Dr. Jens Kiesel  
jkiesel@hydroc.de



May 2018

## Session 4

- Spatial data processing -



Dr. Jens Kiesel  
[jkiesel@hydroc.de](mailto:jkiesel@hydroc.de)



# Content



- Questions from yesterday?
- Problem statement
- What you will learn in this session
- Hands-on work

# Available spatial datasets



Description	Resolution	Source	Year
Digital Elevation Model	1m	Supplied by NEA	unknown
Stream network	Polygon (original resolution unknown)	Supplied by NEA	unknown
Discharge locations for hydraulic model	Point data	Derived within project	2018
Landuse map	Polygon (original resolution unknown)	Supplied by NEA	unknown
Google Earth images	Around 1-10m	Google Earth	2017
Soil map and soil texture	Polygon, 1:200000	Supplied by NEA	unknown

➡ Data sufficient

# Spatial data preparation for HEC-HMS

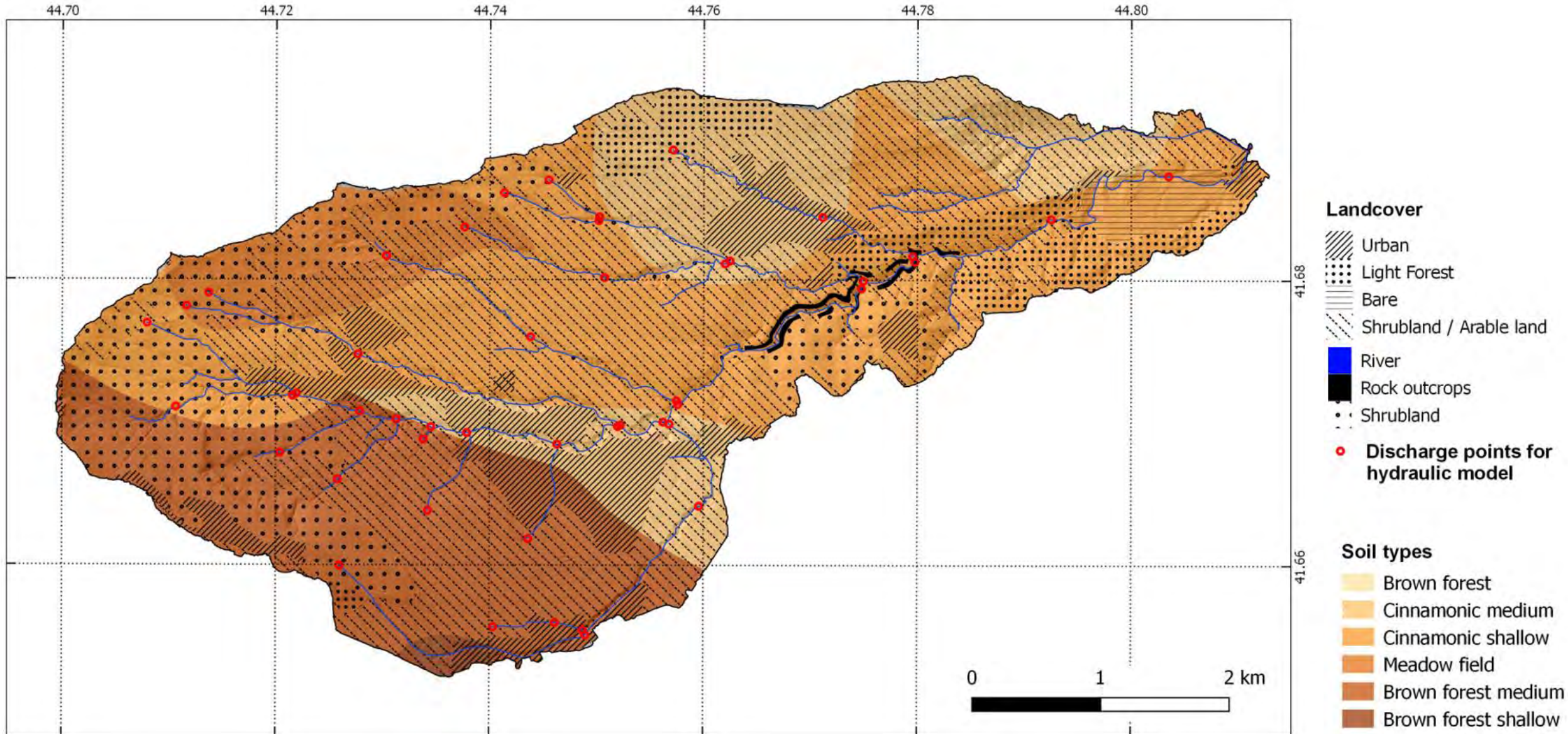

# What you will learn in this session



## **Preparation of**

- (Elevation data)
- Landuse data
- Soil data

**for usage in HEC-HMS**

# Hands-on work



Follow the explanation in the Handout

14.05.2018 – 25.05.2018  
at Ilias State University

# Assessment of Suitable Flood Mitigation Measures in Tbilisi, Georgia

- Hydrologic Modelling Training -



Dr. Jens Kiesel  
jkiesel@hydroc.de



May 2018

# Session 5

## - HEC-GeoHMS tutorial -



Dr. Jens Kiesel  
[jkiesel@hydroc.de](mailto:jkiesel@hydroc.de)



# Content



- Questions from yesterday?
- Problem statement
- What you will learn in this session
- Walking you through the HEC-GeoHMS setup

# Preparation of the HEC-HMS model



- Current version of HEC-HMS 4.2.1 still relies on HEC-GeoHMS for complex models to prepare the input data files
- Next version (HEC-HMS 4.3) will contain GIS capabilities
- HEC-GeoHMS is error-prone:  
[http://www.hec.usace.army.mil/software/hec-geohms/known\\_issues.aspx](http://www.hec.usace.army.mil/software/hec-geohms/known_issues.aspx)  
<https://community.esri.com/thread/43771>  
...and many more

# What you will learn in this session



- How to use (and not use) HEC-GeoHMS

# Walking you through the HEC-GeoHMS setup for the Leghtvakhevi



Follow the live setup and explanation in the Handout

It will be a simplified setup (coarser resolution, less hydraulic modelling points)

14.05.2018 – 25.05.2018  
at Ilias State University

# Assessment of Suitable Flood Mitigation Measures in Tbilisi, Georgia

- Hydrologic Modelling Training -



Dr. Jens Kiesel  
jkiesel@hydroc.de



May 2018

## Session 6

- HEC-HMS introduction, setup and model runs -



Dr. Jens Kiesel  
jkiesel@hydroc.de



# Content



- Questions from last week?
- Schedule for the week
- What you will learn in this session
- Hands-on session

# Schedule for the week



Session	Contents
6	HEC-HMS introduction (Menu items, objects, schematics, data import and change)
	HEC-HMS model runs (creating runs, viewing output, HEC-DSSVue)
7	Sensitivity of HEC-HMS algorithm selection and discussion
	Sensitivity analysis of parameters and input data
8	Model calibration (Vere)
	Parameter transfer to Leghtvakhevi model
9	Design events - running Baseline events and climate change events, Knowledge Test
	Interaction and link to own work
10	Interaction and link to own work
	Outlook (continuous simulations, linking to HEC-RAS), wrap-up, feedback and discussion

# HOMEWORK:

## Interaction and link to own work



Parts of Thursday and Friday can be offered for own work. Please think about the following questions and give feedback until **tomorrow**:

- What concerns or problems do you face in your own day-to-day work where the tools and methods you got to know during the training can help you?
- Can you provide an example or even bring your own data so that we can look into the problems and discuss those?
- What part of the training was most important for you?  
Why?  
And is there a need to dive into that topic deeper?

# What you will learn in this session



- Basics of HEC-HMS
- Adding data to HEC-HMS
- Running the model and viewing results
- The differences between the different HEC-HMS algorithms

# Hands-on session



Follow the explanation in the Handout

14.05.2018 – 25.05.2018  
at Ilias State University

# Assessment of Suitable Flood Mitigation Measures in Tbilisi, Georgia

- Hydrologic Modelling Training -



Dr. Jens Kiesel  
jkiesel@hydroc.de



May 2018

## Session 7

- Sensitivity Analysis – Algorithms, input and parameter changes -



Dr. Jens Kiesel  
jkiesel@hydroc.de



# Content



- Questions from yesterday? – Homework!
- Problem statement
- What you will learn in this session
- Hands-on session

# HOMEWORK:

## Interaction and link to own work



Parts of Thursday and Friday will be offered for own work. Please think about the following questions and give feedback:

- What concerns or problems do you face in your own day-to-day work where the tools and methods you got to know during the training can help you?
- Can you provide an example or even bring your own data so that we can look into the problems and discuss those?
- What part of the training was most important for you?  
Why?  
And is there a need to dive into that topic deeper?

# Own work



We can work on / discuss the following points

- Gridded precipitation input to HEC-HMS (Zviad)
- Free global data sources for regional modelling
- Which software to use for pre-processing of input data
- Black holes (information paradox)
- TR55 method for time of concentration calculation – theoretical background
- What causes different runoffs though rainfall is similar? – answer that question just from looking at data without modelling. Example from any catchment with appropriate data
- R script for calculating return periods
- How do we best simulate complex catchments?

# Problem statement



- We cannot calibrate the parameters in the Leghtvakhevi due to lack of data!
  - We need to get an understanding („feeling“) for how the model behaves under this uncertain data situation
  - We need to understand what we need to focus our efforts on to most effectively improve the situation in the future
- ➔ We need to carry out a sensitivity analysis

# What you will learn in this session



- The impact of different HEC-HMS **algorithms** on discharge
- The impact of different **precipitation data** on discharge
- The impact of different **parameter settings** on discharge

# Introduction to HEC-HMS' algorithms



- The availability of different algorithms in HEC-HMS are the reason why we can call it a ,flexible' hydrological model
- Algorithms are well explained in the User's Manual and the Technical Reference Manual, as well as multiple papers, and Technical Reports
- Some algorithms only work with certain others (not all combinations are possible)
- Algorithms can be set for each subbasin individually

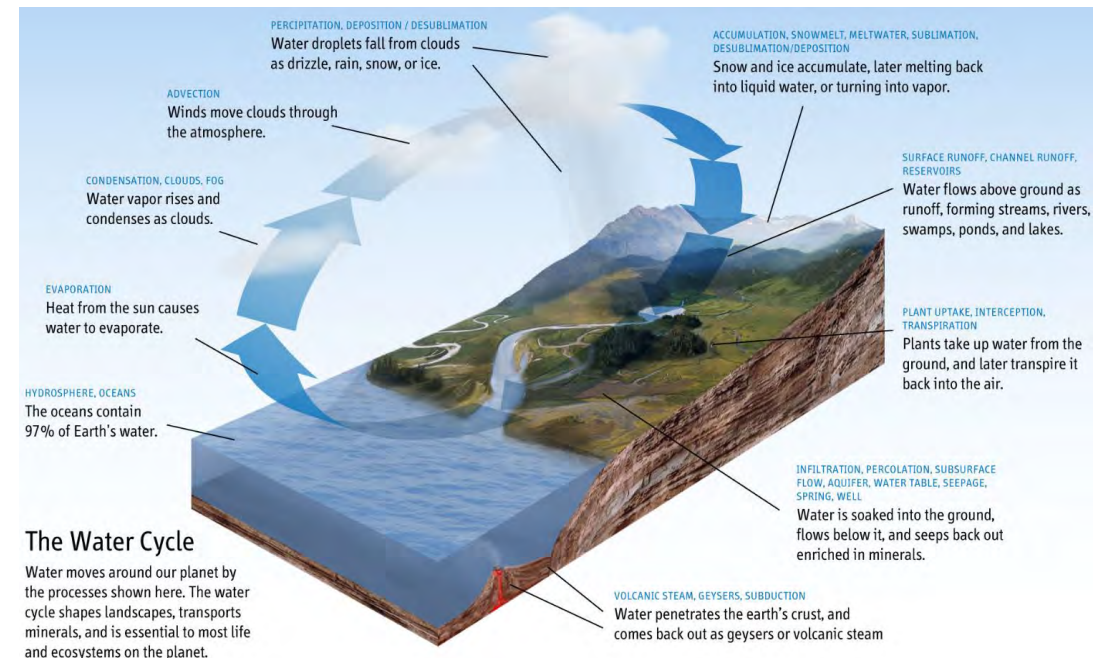

(Creative Commons, 2018, Ehud Tal)

# Canopy method – storage in vegetation



- used to depict interception storage, storage (entered in mm) is emptied through evaporation
- Usually no significant impact for event based modelling, but can have a decisive impact on the water balance for long-term simulations in vegetated areas
- Methods in HEC-HMS:
  - Dynamic Canopy includes varying crop characteristics over time (long-term simulations)
  - Gridded Simple Canopy characteristics constant over time, but distributed over grid cells
  - **Simple Canopy** characteristics constant over time and for each subbasin

# Surface method – storage on surface



- Used to depict depression storage of the surface of the watershed, storage is emptied through evaporation
- Usually no significant impact on event based modelling, but can have a decisive impact on the water balance for long-term simulations in particular areas
- Methods in HEC-HMS:
  - Gridded Simple Surface      characteristics constant over time, but distributed over grid cells
  - **Simple Surface**              characteristics constant over time and for each subbasin

# Loss method - infiltration calculations



- Calculate runoff volumes for each time step, using twelve different methods – the most commonly used are both available grid-based and lumped:
  - **Deficit/Initial and Constant** - Infiltration based on saturated hydraulic conductivity
    - Well established, simple
  - **SCS - Curve Number** - Infiltration based on numbers established from small US watersheds
    - Well established, simple, but rainfall intensity not considered
  - **Soil Moisture Accounting** - Long-term simulations through tracking soil moisture and groundwater
    - Complex soil parameters need to be available, calibration over years
  - **Green and Ampt** - Solves Richard's eqn. (physically infiltration of unsaturated Darcy law)
    - Rarely used, complex parameterization

# Transform method – PCP to runoff



- Calculate the transformation of excess precipitation (defined through the loss method) to actual surface runoff using the following options:
  - Kinematic Wave
    - The only conceptual transform model in HMS, for small watersheds
    - Complex, best in ungauged basins, unfortunately bug in 4.2.1
  - User specified UH
    - Derived for each subbasin from observed pcp and runoff
  - SCS-Unit hydrograph (UH)
    - Based on many watersheds in US, only for single-peaked watersheds
    - Adaptable to basin characteristics through a Peak Rate Factor
  - **Clark/Mod Clark**
    - well suited for unusually shaped watersheds with escarpments and valleys

# Baseflow method – groundwater flow



- Calculate the amount of groundwater flow in each subbasin:
  - Recession Baseflow - Baseflow definition and monthly recession constant
  - Nonlinear Boussinesq - Special form of the Recession baseflow with Boussinesq equation
  - **Constant Monthly Baseflow** - Baseflow value for each month
  - Linear Reservoir - Two linear reservoirs connected to infiltration (conserves mass)

# Routing method – flow in channel



- Calculate the travel time, attenuation, diffusion of flood wave in the stream channel:
  - **Kinematic Wave**
    - Approximates unsteady flow equations
    - best suited for steep and ungauged streams
  - Lag routing
    - Translation of flood wave for short, simple streams
  - Modified Puls
    - Use if floodwave will reach floodplain, difficult parameterization
    - useful for backwater effects
  - Muskingum (Cunge)
    - Popular method, use if floodwave will reach floodplain
    - appropriate also for very low channel slopes
  - Straddle Stagger
    - empirical representation of translation and attenuation

# Channel Loss/Gain – GW interaction



- Calculate loss of water in the reach to the groundwater or vice-versa:
  - Constant Loss/Gain
    - empirical relationship using a fixed flow rate and fraction
    - works with all methods
  - Percolation
    - Constant infiltration rate for losses only
    - Modified Puls and Muskingum routing

# Algorithms impact on discharge



- Impact of the different methods or switching on Canopy, Surface, Baseflow and Channel Losses/Gains during event simulation is (relatively) predictable
- We will test the impact of
  - Loss methods: SCS-CN Method vs. Initial and Constant
  - Transform methods: SCS-Unit Hydrograph vs. ModClark
  - Routing methods: Kinematic Wave vs. Muskingum-Cunge

# Hands-on session



Follow the explanation in the Handout

# Precipitation impact on discharge



- We will test the impact of
  - the different radar disaggregation events
  - different time steps

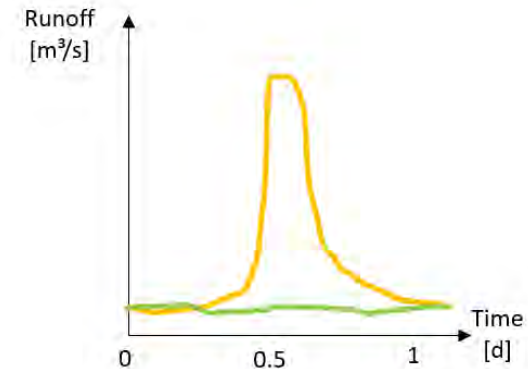
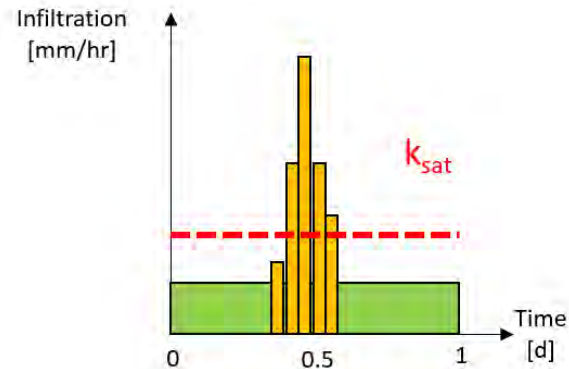
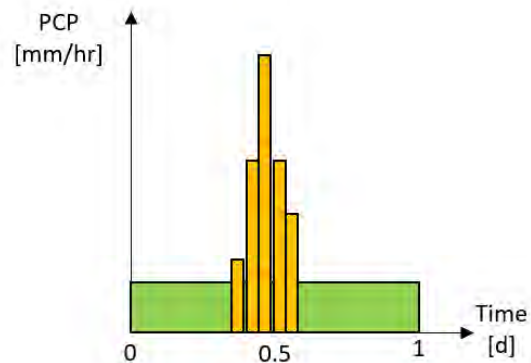
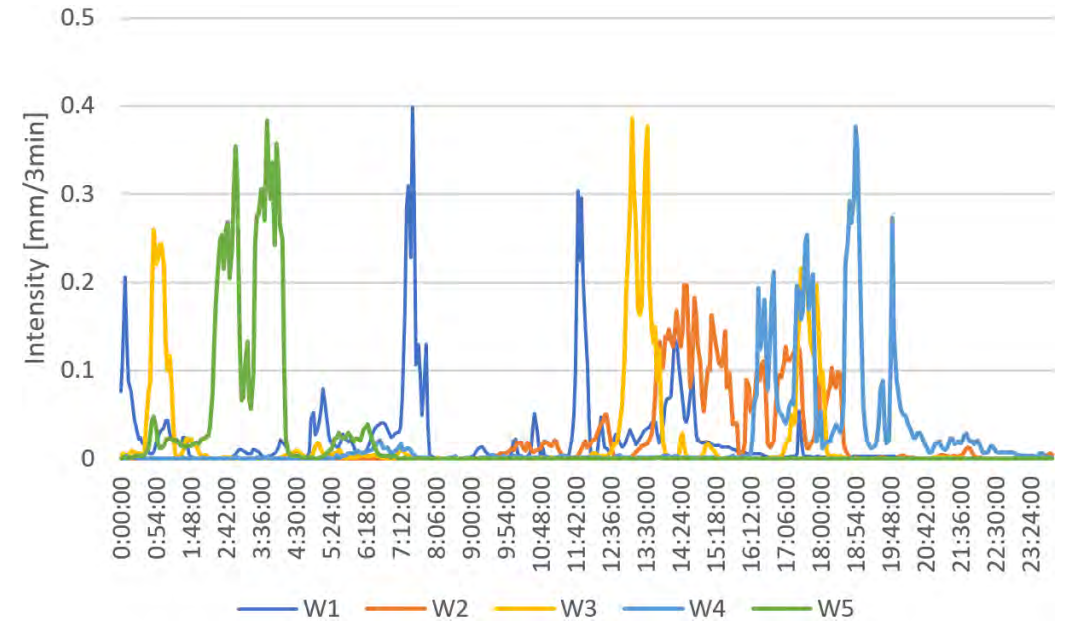

# Hands-on session



Follow the explanation in the Handout

# Impact of parameter settings on discharge



- We will test the impact of
  - loss parameters
  - transformation parameters
  - routing parameters

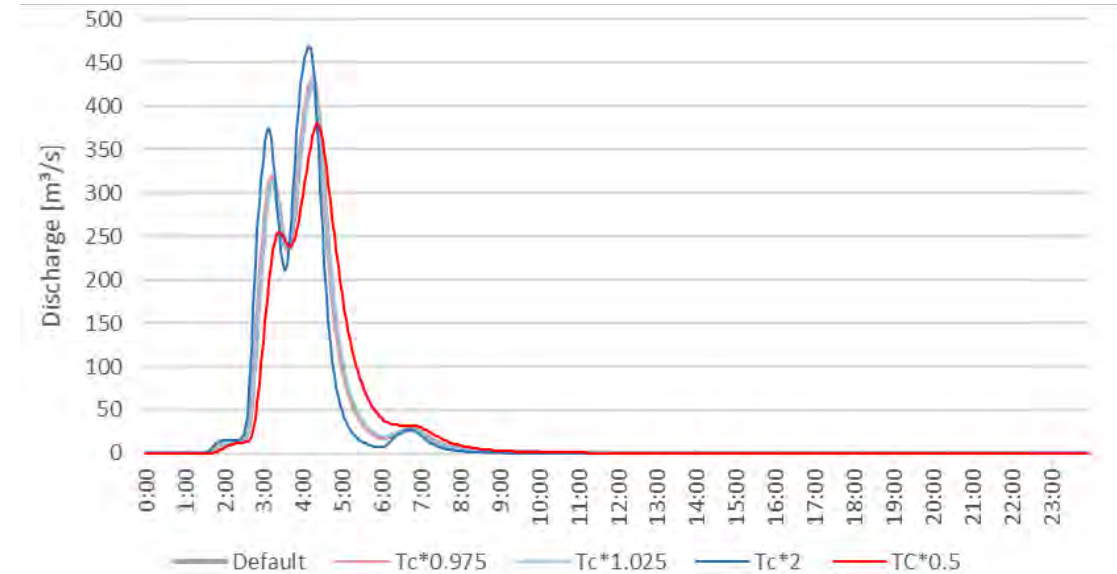

	Width times 0.5	Width times 2	Side Slope = 1	Side Slope = 4	Mannings n = 0.03	Mannings n = 0.05
Peak flow change [%]	-0.1%	0.0%	+ 0.3%	-1.0%	+ 0.7%	-0.4%

# Hands-on session



Follow the explanation in the Handout

14.05.2018 – 25.05.2018  
at Ilias State University

# Assessment of Suitable Flood Mitigation Measures in Tbilisi, Georgia

- Hydrologic Modelling Training -



Dr. Jens Kiesel  
jkiesel@hydroc.de



May 2018

## Session 8

- HEC-HMS calibration in Vere and parameter transfer -



Dr. Jens Kiesel  
jkiesel@hydroc.de



# Content



- Questions from yesterday?
- Problem statement
- What you will learn in this session
- Hands-on session

# Problem statement



- The Leghtvakhevi is an ungauged catchment
- Hydrological science is aware of that (common) problem:
  - Regionalization methods in hydrology  
<https://www.hydrol-earth-syst-sci.net/9/157/2005/hess-9-157-2005.pdf>
  - The IAHS hydrological decade on „Predictions in Ungauged Basins“ (PUB, 2003-2012)  
<https://iahs.info/Commissions--W-Groups/Working-Groups/Prediction-in-Ungauged-Basins.do>
- The Vere River is significantly close with similar soils, land use and slopes and has (some) observed discharge data available

# Discharge data Vere

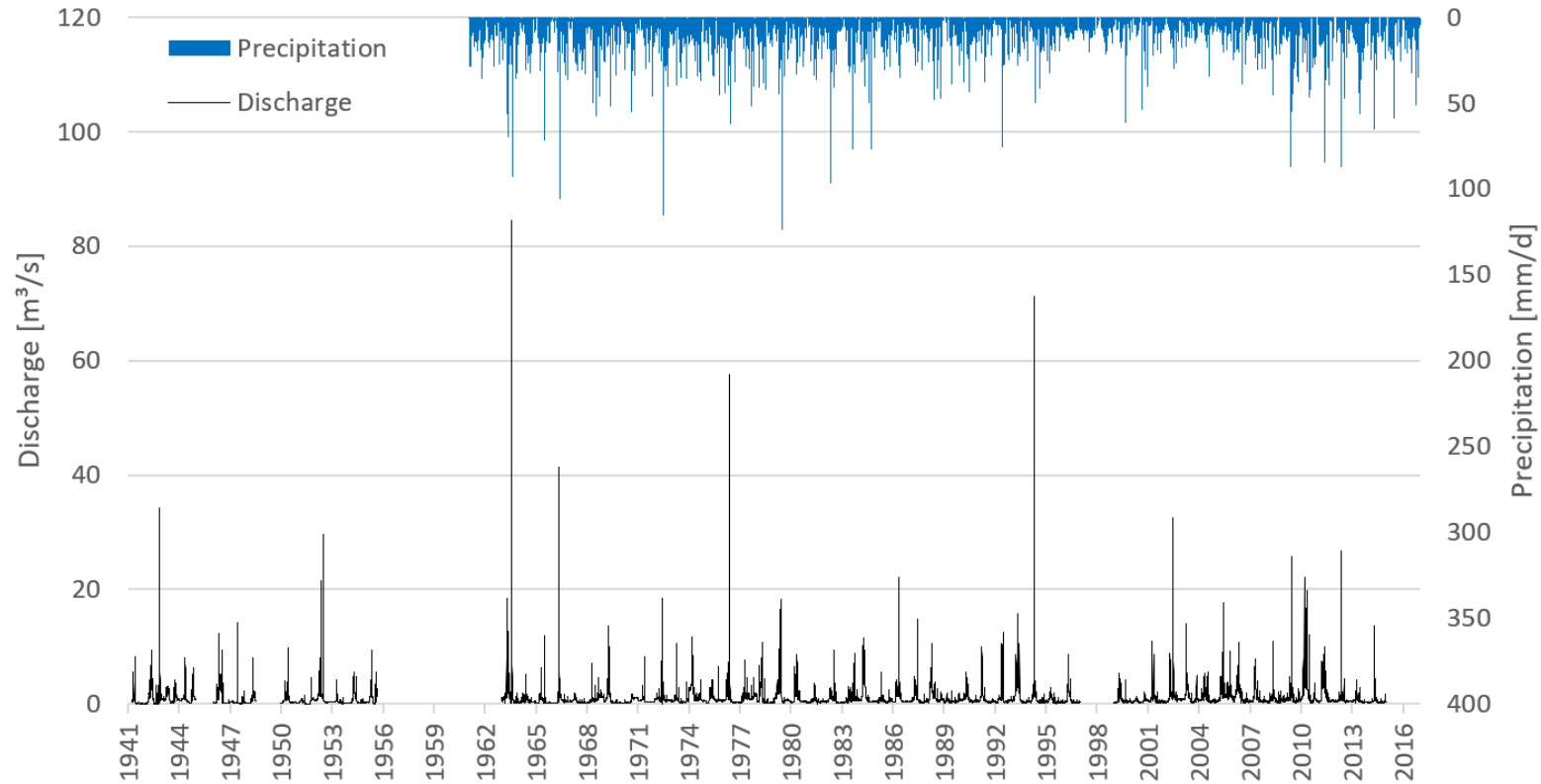

- Discrepancies with hydrological reports exist:  
1972: 155.3m<sup>3</sup>/s  
1960: 259m<sup>3</sup>/s
- No significant impact of groundwater or snowmelt processes

„If **time steps** are chosen **too long**, the **peak runoff** rate is systematically **too small**“

# Problems arising from daily discharge observations in small catchments



- Daily vs subdaily observed discharge => Problem in assessing model result

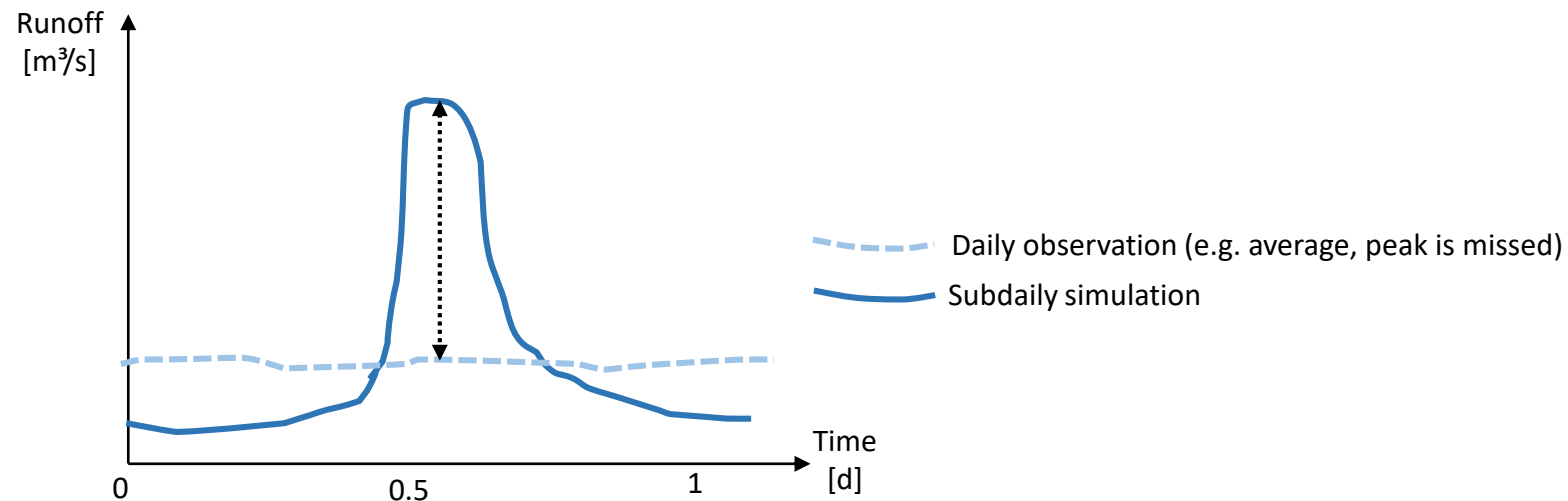

- ➔ We need to carry out subdaily discharge observations to calibrate the model to peak flows
- ➔ Calibration only possible to **runoff volumes** in the Vere

# HEC-HMS Vere calibration



- Calibration of the Loss method
- Initial and constant loss method: the soil infiltration capacity under saturated conditions (saturated hydraulic conductivity,  $k_{sat}$ )

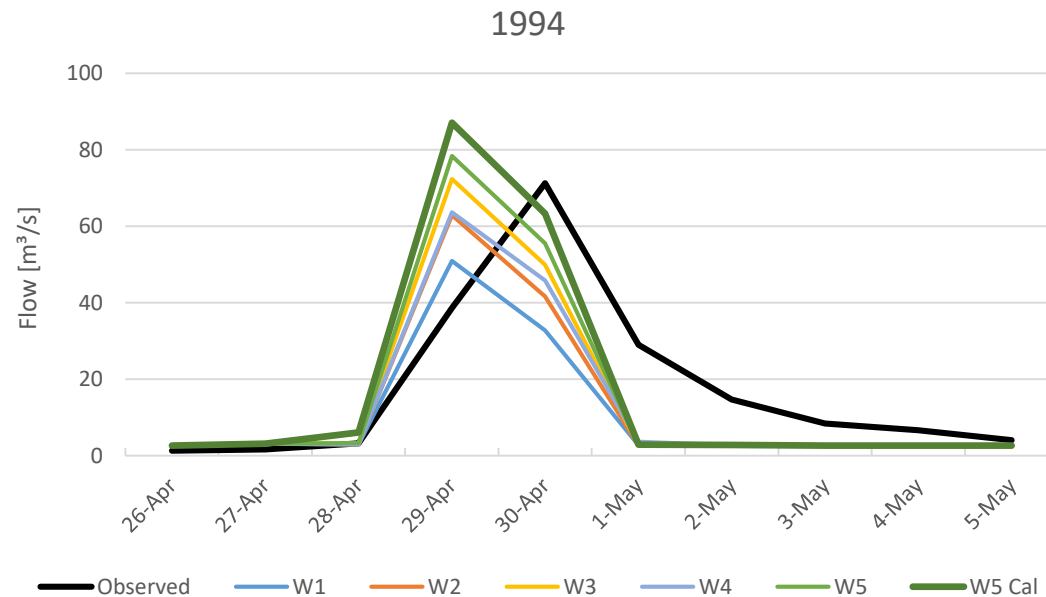

# What you will learn in this session



- Introduction to the Vere model
- Calibration events preparation
- Carrying out calibration
- Parameter transfer to Leghtvakhevi

# Hands-on session



Follow the explanation in the Handout

14.05.2018 – 25.05.2018  
at Ilias State University

# Assessment of Suitable Flood Mitigation Measures in Tbilisi, Georgia

- Hydrologic Modelling Training -



Dr. Jens Kiesel  
jkiesel@hydroc.de



May 2018

## Session 9

- Design events in Leghtvakhevi, knowledge Test, own work -



Dr. Jens Kiesel  
jkiesel@hydroc.de



# Content



- Questions from yesterday?
- What you will learn in this session
- Hands-on session

# What you will learn in this session



- Simulating baseline and climate change events in HEC-HMS
- Analysing and comparing the results

# Hands-on session



Follow the explanation in the Handout

# A short evaluation of your knowledge



Fill out the provided test form

# Own work and joint discussions



- How can we get gridded precipitation input to HEC-HMS?
- TR55 method for time of concentration calculation – theoretical background
- What causes different runoffs though rainfall is similar? – answer that question just from looking at data without modelling. Example from any catchment with appropriate data
- Which software to use for pre-processing of input data?
- How do we best simulate complex catchments?
- Free global data sources for regional modelling
- R script for calculating return periods
- Black holes (information paradox)  
<https://www.youtube.com/watch?v=yWO-cvGETRQ>

# Own work and joint discussions



- **How can we get gridded precipitation input to HEC-HMS?**
- TR55 method for time of concentration calculation – theoretical background
- What causes different runoffs though rainfall is similar? – answer that question just from looking at data without modelling. Example from any catchment with appropriate data
- Which software to use for pre-processing of input data?
- How do we best simulate complex catchments?
- Free global data sources for regional modelling
- R script for calculating return periods
- Black holes (information paradox)  
<https://www.youtube.com/watch?v=yWO-cvGETRQ>

# (Radar) Grids to HEC-HMS



- Via the HEC-GridUtils
  - <http://www.hec.usace.army.mil/software/hec-gridutil/>
  - Contains a small command line-based tool that loads NetCDF files to the .DSS file
  - HEC-HMS then can extract the rainfall time series from the files stored in the .DSS
- Custom-built
  - Calculate the radar rainfall over each subbasin and time step
  - Write the resulting values to the rain-gage time series (directly to the .DSS and the HEC-HMS input files)

# Own work and joint discussions



- How can we get gridded precipitation input to HEC-HMS?
- **TR55 method for time of concentration calculation – theoretical background**
- What causes different runoffs though rainfall is similar? – answer that question just from looking at data without modelling. Example from any catchment with appropriate data
- Which software to use for pre-processing of input data?
- How do we best simulate complex catchments?
- Free global data sources for regional modelling
- R script for calculating return periods
- Black holes (information paradox)  
<https://www.youtube.com/watch?v=yWO-cvGETRQ>

# Theory behind TR-55 method for calculating Time of Concentration



- Let's have a closer look at the Technical Report 55 by the NRCS, pages 3-1 and following...

# Own work and joint discussions



- How can we get gridded precipitation input to HEC-HMS?
- TR55 method for time of concentration calculation – theoretical background
- **What causes different runoffs though rainfall is similar? – answer that question just from looking at data without modelling. Example from any catchment with appropriate data**
- Which software to use for pre-processing of input data?
- How do we best simulate complex catchments?
- Free global data sources for regional modelling
- R script for calculating return periods
- Black holes (information paradox)  
<https://www.youtube.com/watch?v=yWO-cvGETRQ>

# Catchment characteristics



Investigating catchment characteristics in four catchments across Germany

(Guse et al. under review in JOH)

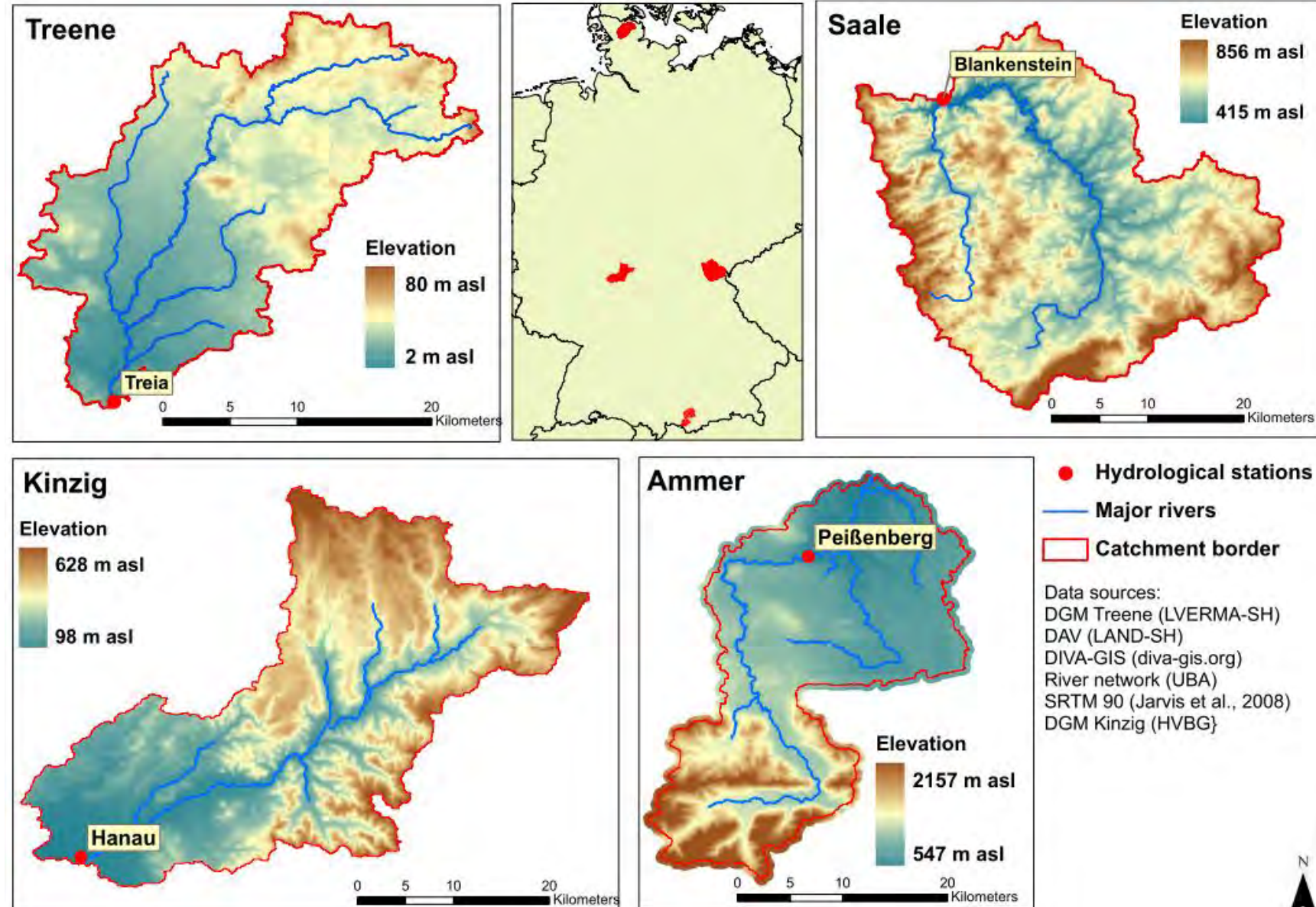

# Rainfall – Runoff dependencies

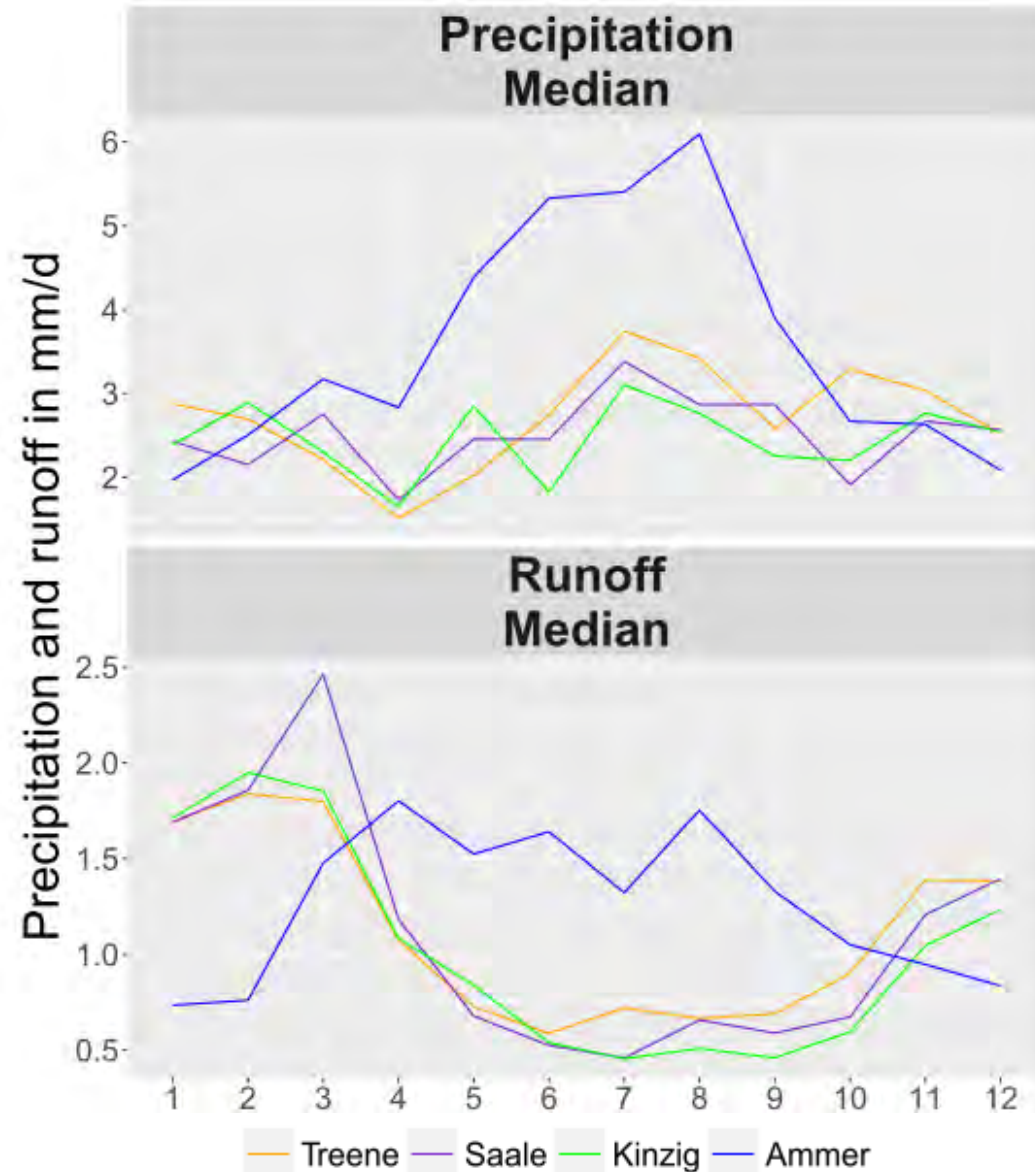

(Guse et al. under review in JOH)

# Rainfall – Runoff dependencies

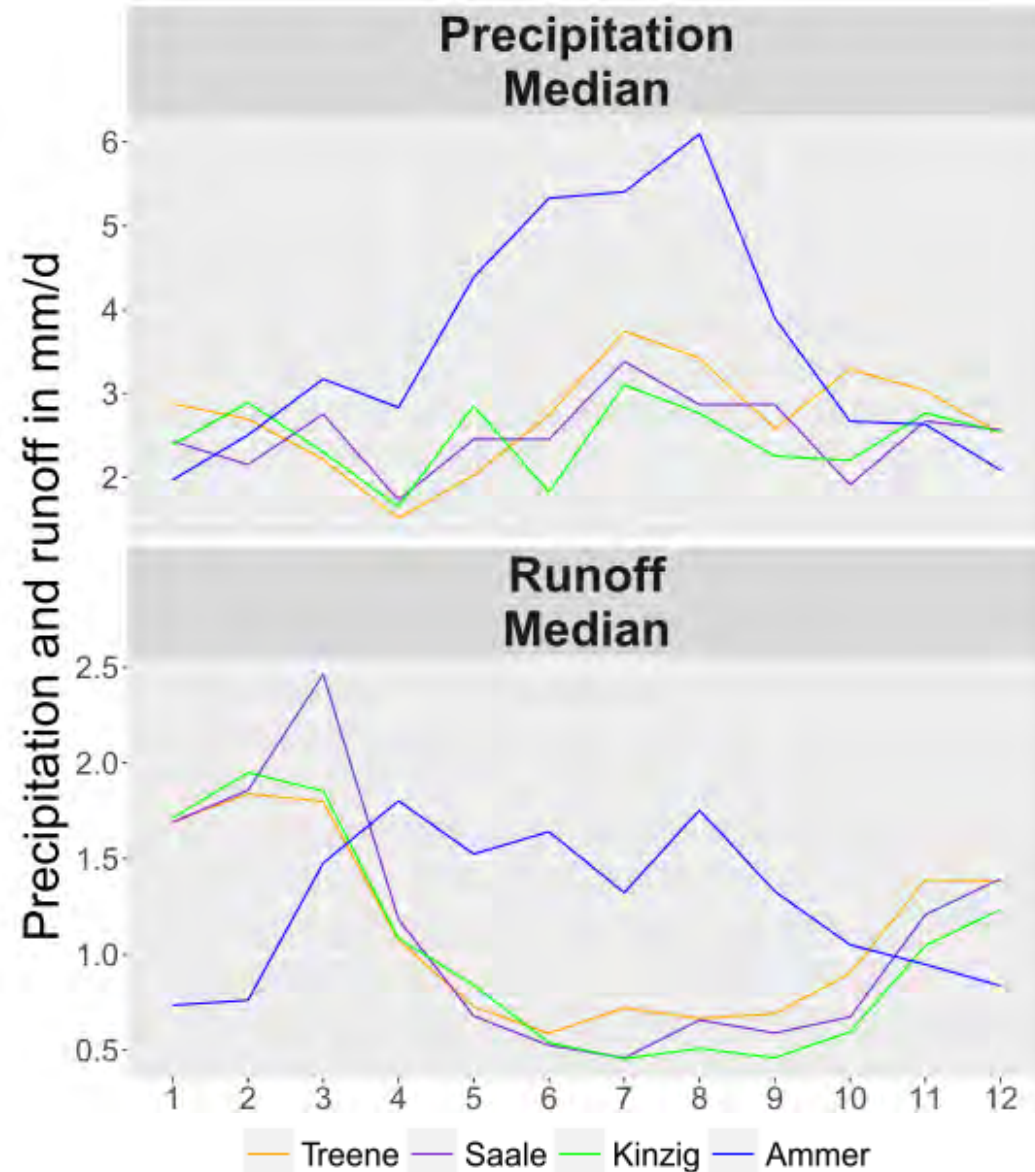

(Guse et al. under review in JOH)

# Catchment processes (obs and sim)

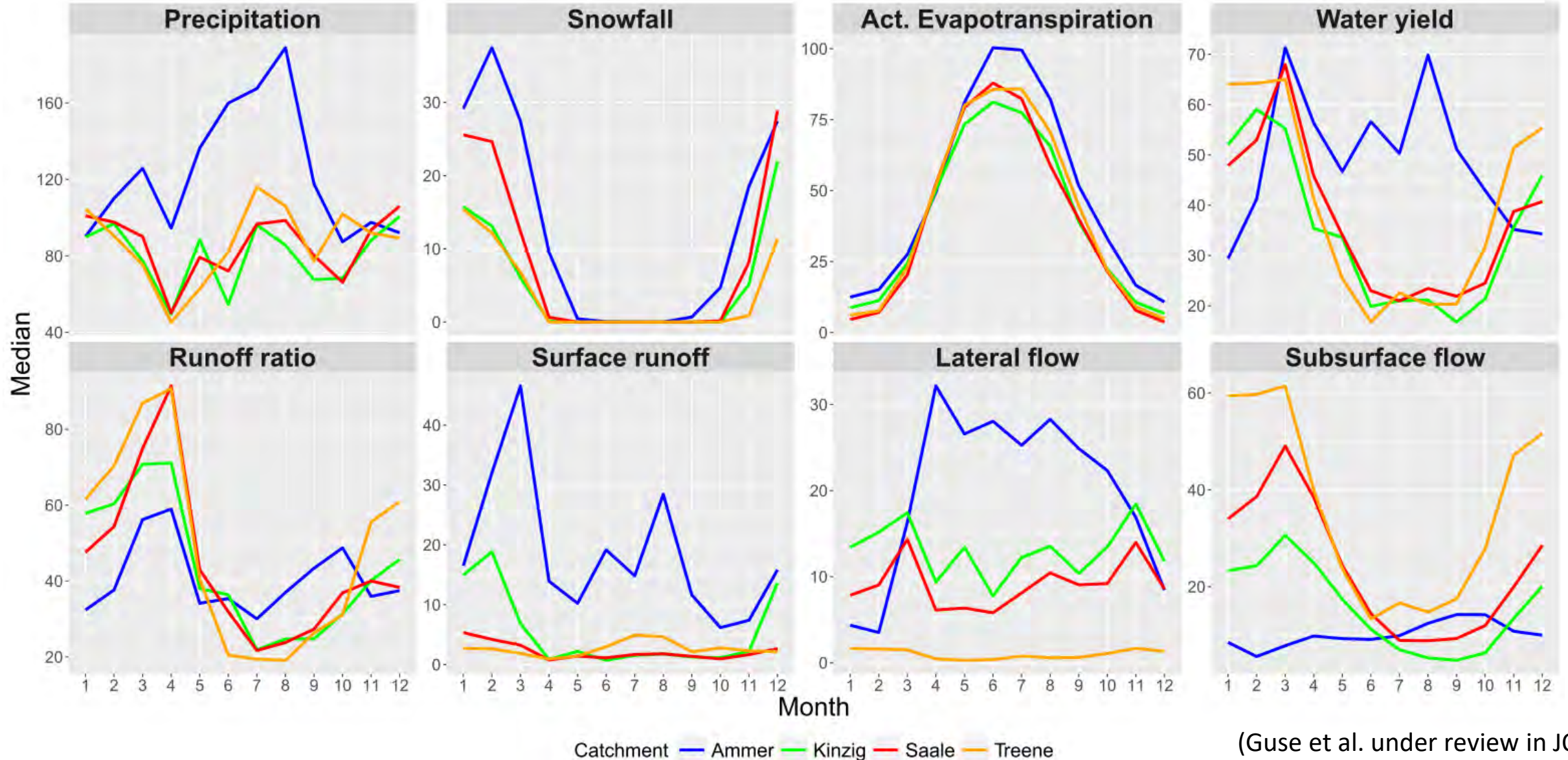

(Guse et al. under review in JOH)

# Auto-correlation as a tool to identify catchment characteristics



Precipitation

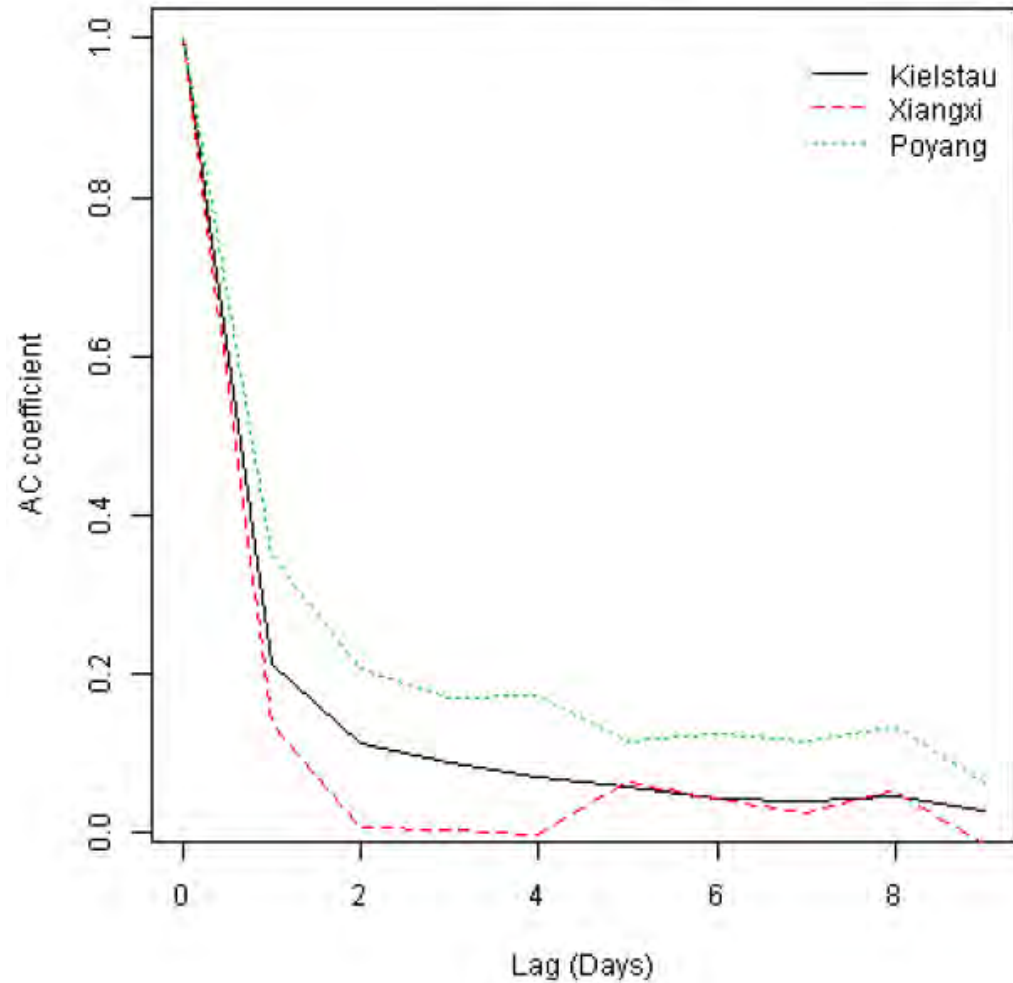

Discharge

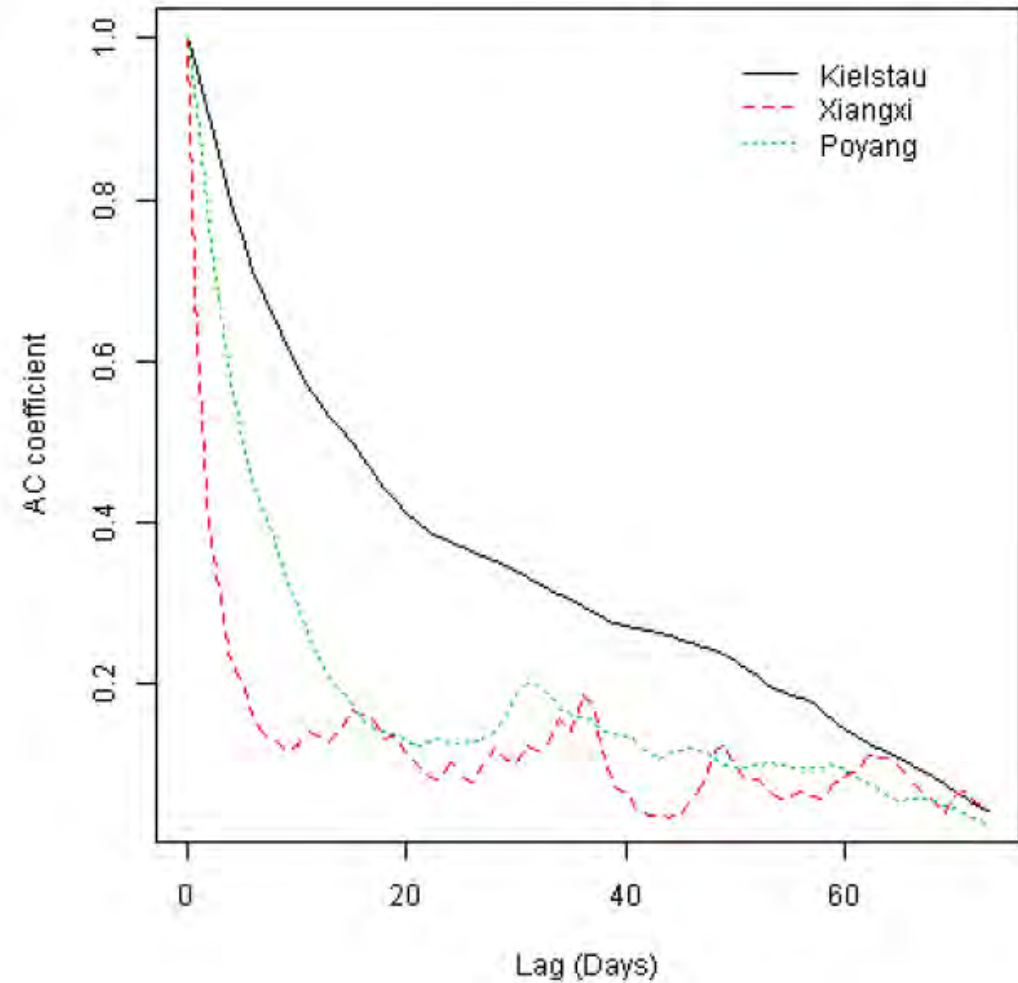

# Own work and joint discussions



- How can we get gridded precipitation input to HEC-HMS?
- TR55 method for time of concentration calculation – theoretical background
- What causes different runoffs though rainfall is similar? – answer that question just from looking at data without modelling. Example from any catchment with appropriate data
- **Which software to use for pre-processing of input data?**
- How do we best simulate complex catchments?
- Free global data sources for regional modelling
- R script for calculating return periods
- Black holes (information paradox)  
<https://www.youtube.com/watch?v=yWO-cvGETRQ>

# Software for pre-processing of data



- Time series data:
  - Excel / **LibreOffice** (few stations, short durations)
  - R with R Studio
  - Python with Pandas
- Spatial data for hydrology:
  - QGIS (+ SAGA)
  - QSWAT
  - GRASS (!!!)
  - TauDEM
- Batch processing of data:
  - Python (and it's modules)
  - QGIS and it's Batch Processing mode

# Own work and joint discussions



- How can we get gridded precipitation input to HEC-HMS?
- TR55 method for time of concentration calculation – theoretical background
- What causes different runoffs though rainfall is similar? – answer that question just from looking at data without modelling. Example from any catchment with appropriate data
- Which software to use for pre-processing of input data?
- **How do we best simulate complex catchments?**
- Free global data sources for regional modelling
- R script for calculating return periods
- Black holes (information paradox)  
<https://www.youtube.com/watch?v=yWO-cvGETRQ>

# Approaches to simulate complex catchments



1. Model conceptualization – abstraction process of the reality
  - What is the target/aim of the project/model?
  - What is important (include), what is certainly negligible (neglect) – if in doubt, include it!
  
2. Find a suitable tool
  - Must be capable to depict the important processes
  - Must be available to you and the project
  - You must be able to handle it, ideally on your own
  - If nothing is available – use the closest and add calculations/processes externally
  
3. Apply the tool
  - Always keep (1) in your mind, e.g.:
    - flooding: resolve and match peak flows and timing
    - water allocation: supply and demand volumes and timings
    - irrigation: available storages and dry periods (baseflows and groundwater)
    - ....

# Own work and joint discussions



- How can we get gridded precipitation input to HEC-HMS?
- TR55 method for time of concentration calculation – theoretical background
- What causes different runoffs though rainfall is similar? – answer that question just from looking at data without modelling. Example from any catchment with appropriate data
- Which software to use for pre-processing of input data?
- How do we best simulate complex catchments?
- **Free global data sources for regional modelling**
- R script for calculating return periods
- Black holes (information paradox)  
<https://www.youtube.com/watch?v=yWO-cvGETRQ>

# Useful global data sources



- Open the table I provided in folder „10\_WrapUp\_Discussion“:  
*“UsefulGlobalDataSources.xlsx”*
- Maximum rooting depth of vegetation – see  
*“MaximumRootingDepth.pdf”* in “10\_WrapUp\_Discussion”

# Own work and joint discussions



- How can we get gridded precipitation input to HEC-HMS?
- TR55 method for time of concentration calculation – theoretical background
- What causes different runoffs though rainfall is similar? – answer that question just from looking at data without modelling. Example from any catchment with appropriate data
- Which software to use for pre-processing of input data?
- How do we best simulate complex catchments?
- Free global data sources for regional modelling
- **R script for calculating return periods**
- Black holes (information paradox)  
<https://www.youtube.com/watch?v=yWO-cvGETRQ>

# Return Periods



- Let's look again at the R script
  - Session 2....

# Own work and joint discussions



- How can we get gridded precipitation input to HEC-HMS?
- TR55 method for time of concentration calculation – theoretical background
- What causes different runoffs though rainfall is similar? – answer that question just from looking at data without modelling. Example from any catchment with appropriate data
- Which software to use for pre-processing of input data?
- How do we best simulate complex catchments?
- Free global data sources for regional modelling
- R script for calculating return periods
- **Black holes (information paradox) ;)**  
<https://www.youtube.com/watch?v=yWO-cvGETRQ>

# Look at the “Kurzgesagt” channel



- Black holes (information paradox) ;)

<https://www.youtube.com/watch?v=yWO-cvGETRQ>

14.05.2018 – 25.05.2018  
at Ilias State University

# Assessment of Suitable Flood Mitigation Measures in Tbilisi, Georgia

- Hydrologic Modelling Training -



Dr. Jens Kiesel  
jkiesel@hydroc.de



May 2018

## Session 10

- Own work, discussions, outlook and wrap-up of the Training -



Dr. Jens Kiesel  
[jkiesel@hydroc.de](mailto:jkiesel@hydroc.de)



# Content



- Questions from yesterday?
- Continuation of own work
- Outlook
- Summary
- Feedback, Evaluation

# Content



- Questions from yesterday?
- **Continuation of own work**
- Outlook
- Summary
- Feedback, Evaluation

# Content



- Questions from yesterday?
- Continuation of own work
- **Outlook**
- Summary
- Feedback, Evaluation

# Outlook



- **Transfer HEC-HMS discharges at all subbasins to HEC-RAS to obtain inundation maps**

# Outlook – Link to HEC-RAS



First indicative results (Juan Fernandez)

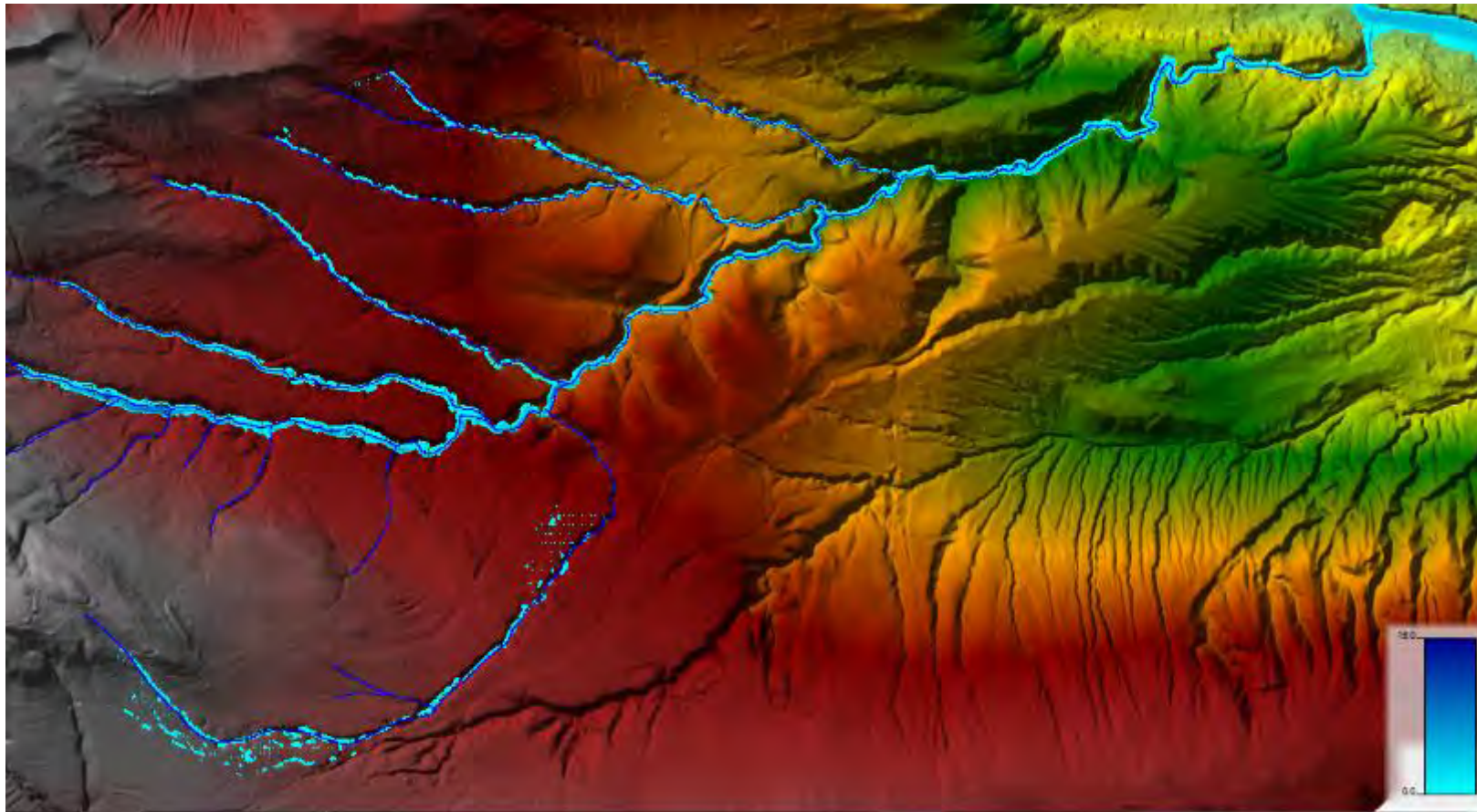

# Outlook – Link to HEC-RAS



First indicative results (Juan Fernandez)



# Outlook – Link to HEC-RAS



First indicative results (Juan Fernandez)



# Outlook – Link to HEC-RAS



First indicative results (Juan Fernandez)



# Outlook – Link to HEC-RAS



First indicative results (Juan Fernandez)



# Outlook – Link to HEC-RAS



First indicative results (Juan Fernandez)



# Outlook



- Transfer HEC-HMS discharges at all subbasins to HEC-RAS to obtain inundation maps
- **This represents the basis for planning mitigation measures**

# Outlook – Flood mitigation measures



- The flood mitigation and adaptation options to be developed as part of the project will be modelled in the hydraulic model when necessary

- **Prevention**
- **Protection**
- **Preparation**

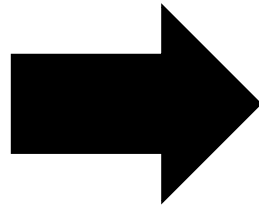

**Structural and  
non-structural  
measures**

- Close collaboration among all stakeholders

# Outlook



- Transfer HEC-HMS discharges at all subbasins to HEC-RAS to obtain inundation maps
- This represents the basis for planning mitigation measures
- **Starting point to refine simulations if new data become available**

# Actual model represents starting point



- All efforts were made to utilize all available data sources, methodologies and analysis in an unprecedented level of detail
- Still, uncertainties of the design estimates are high
- As soon as new data become available (sub-daily rainfall and sub-daily discharge for significant storm events), it is suggested to update the model

# Outlook



- Transfer HEC-HMS discharges at all subbasins to HEC-RAS to obtain inundation maps
- This represents the basis for planning mitigation measures
- Starting point to refine simulations if new data become available
- **Continuous model (e.g. for early warning) requires additional (ET, snowmelt) and different model algorithms selection (soil moisture accounting, linear baseflow)**

# Recommendations regarding early warning system



- For establishing an early warning system, reliable weather forecast and real-time radar data processing is most important due to the fast catchment response
- A first, simple system could be established by combining:
  - the processing of soil moisture data
  - a simple soil moisture model (e.g. on a daily time step)
  - weather forecasts
  - ground-radar data and the movement of storms
  - near-real-time space-borne radar (e.g. GPM) and the movement of storms
- More advanced systems could link the established models – but those need to be adapted (ET, snowmelt, continuous soil moisture, adjustment of time steps)

# Recommendations regarding early warning system



Further reading:

**FLASH FLOOD  
EARLY WARNING SYSTEM  
REFERENCE GUIDE**



[http://www.meted.ucar.edu/communities/hazwarnsys/ffewsrsg/FF\\_EWS.pdf](http://www.meted.ucar.edu/communities/hazwarnsys/ffewsrsg/FF_EWS.pdf)

# Content



- Questions from yesterday?
- Continuation of own work
- Outlook
- **Summary**
- Feedback, Evaluation

# You learned in this training...



- ... that modelling efforts were severely hindered by the temporal data availability
- ... how to deal with this data shortage through:
  1. linear extrapolation of daily rainfall data and utilizing radar data
  2. calibration of the Vere model including parameter transfer
- ... how to prepare spatial input data for HEC-GeoHMS
- ... a step-by step procedure of setting up the model in HEC-GeoHMS

# You learned in this training...



- ... how to use HEC-HMS
- ... that HEC-HMS has multiple algorithms available and how those impact the simulation
- ... what assumptions and parameters are most sensitive in the Leghtvakhevi model
- ... approximate design flows and what might happen under climate change
- ... what can and should be done to improve the simulations and what the implications are for establishing an early warning system

# Content



- Questions from yesterday?
- Continuation of own work
- Outlook
- Summary
- **Discussion, Feedback, Evaluation**

Dr. Jens Kiesel  
jkiesel@hydroc.de

Thank you for your participation and great work!

HYDROC GmbH  
Siegum 4, 24960 Siegum, Germany  
Managing Director: Dr. Georg Petersen

## 2.2 Hydraulic Modelling handout and presentations given during the Training

# ASSESSMENT OF SUITABLE FLOOD MITIGATION MEASURES (BASED ON DUKNISKHEVI RIVER EXTREME FLOOD ANALYSIS) IN TBILISI, GEORGIA

Hydraulic Modelling Training  
Juan Fernandez Sainz  
July 2018

# INDEX

1. Introduction
2. The need for inundation modelling
3. Flow processes in compound channels
4. Flooding processes

# FLOODING

Flooding is an extreme event that could cause great destruction to property, agriculture & farming, and human lives. The definition of an “extreme event” is something that occurs infrequently, and that is in some way greater (or smaller) than the conditions that exist for most of the time.

The first step in comparing flood events is to decide which characteristic is the most important.

# FLOODING

## Characteristics of a flood

1. The magnitude : How severe or intense is it at the most severe?
2. The duration: How long did the event last?
3. The frequency: How long, on average, is it since the last event of similar size?

# NEED FOR RIVER HYDRAULIC STUDIES

- Flood Control
- Navigation
- Erosion Control
- Water Management
  - Irrigation
  - Hydropower
  - Water supply
  - etc

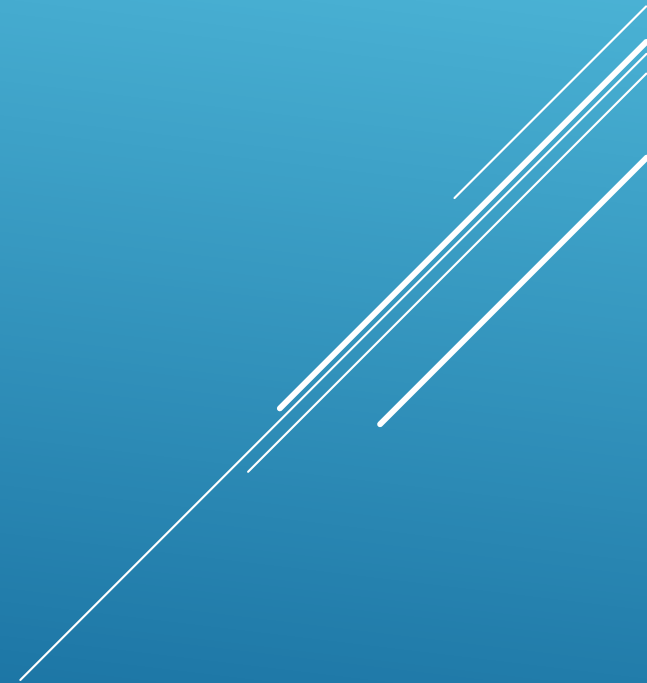

# FLOW BEHAVIOUR

- ▶ Modelling river flows requires an in-depth understanding of flow behaviour in open channels as well as an understanding as to how those channels might change their geometry as the bed or banks erode and hence the river changes its direction or at least cross sectional area. These changes in:
  1. Bed roughness: movement of sediments, exposure of rock strata, water weed,
  2. Velocity: collapsed banks, increased flow rates and tidal influences may induce significant and rapid velocity changes,
  3. Slope and Depth: Depositing sediments or erosion of the bed cause slope and depth changes with time,
  4. Plan-form: Rivers change course in complex ways and braided streams, meandering

# TYPES OF FLOW

- Laminar flow versus Turbulent flow
- Steady flow versus Unsteady flow
- Uniform flow versus non-uniform flow
- Sub-critical versus supercritical flow



# REYNOLDS NUMBER

## ► Reynolds Number Effects

The non-dimensional Reynolds number quantifies the relative influence of the Viscous and Inertia forces on the character of the flow. The magnitude of the following ratio, Reynolds Number,

$$\text{Re} = \frac{\rho u L}{\mu} = \frac{u L}{\nu}$$

Where

- $u$  = Velocity, m/s
- $\rho$  = water density, 1000 kg/m<sup>3</sup>
- $\mu$  = water viscosity, kg/ms
- $\nu$  = kinematic viscosity, m<sup>2</sup>/s
- $L$  = a characteristic length, commonly taken as the cross sectional area of the flow measured perpendicular to the flow direction divided by the wetted perimeter. This parameter is referred to as the Hydraulic radius.

# REYNOLDS NUMBER

## ▶ Laminar Flows

A Reynolds number less than 500 implies that the flow is laminar. Thus the viscous nature of the water dominates and flow is very ordered with streamlines being parallel and free from major transverse flows. Mixing between layers of fluid is therefore minimal.

## ▶ Turbulent Flows

Above a Reynolds number of 2000 the inertia forces dominate and velocity effects dominate the flow. Intense mixing occurs and parcels of fast moving liquid are moved from areas far from the solid boundary to the boundary and vice the versa. This would imply in fixed bed flows that there is a strong likelihood of sedimentary movement with the high velocities scouring and transferring the particles into the upper levels of the flow.

## ▶ Transitional Flows

Between  $Re=500$  and  $Re=2000$  the flow is in transition and exhibits characteristics somewhere between those described above. In closed pipe flows the following two sketches illustrate the difference between these two flow regimes.

# MORE TYPES OF FLOWS

## *Steady Vs. Unsteady Flow*

- ▶ **Steady flow** happens if the conditions (flow rate, velocity, depth etc) do not change with time.
- ▶ Obviously the flow that does change with time is unsteady flow.

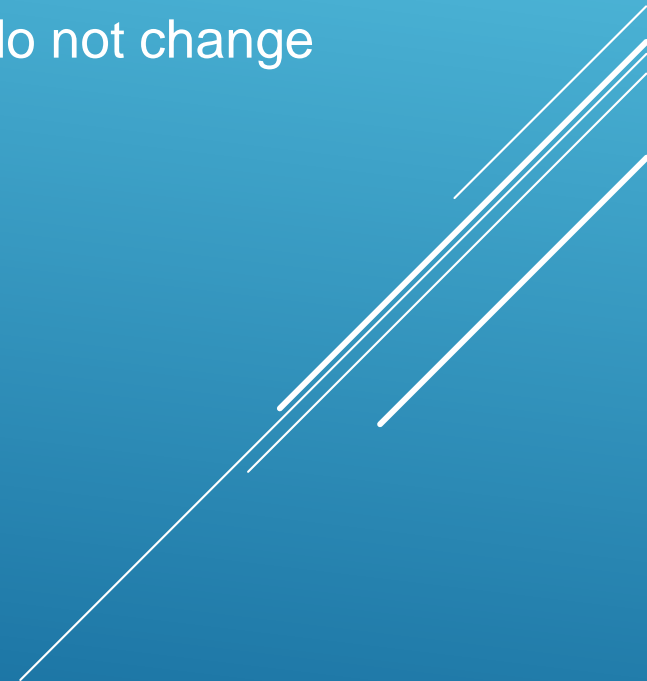

# WHEN TO USE UNSTEADY FLOW

- ▶ Tidal/estuary fluctuation
- ▶ Off-channel storage
- ▶ Dam breach routing
- ▶ Channels with flat slopes
- ▶ Levee overtopping
- ▶ Hydraulic structures affected by changing backwater
- ▶ Large amounts of storage behind roads or culverts

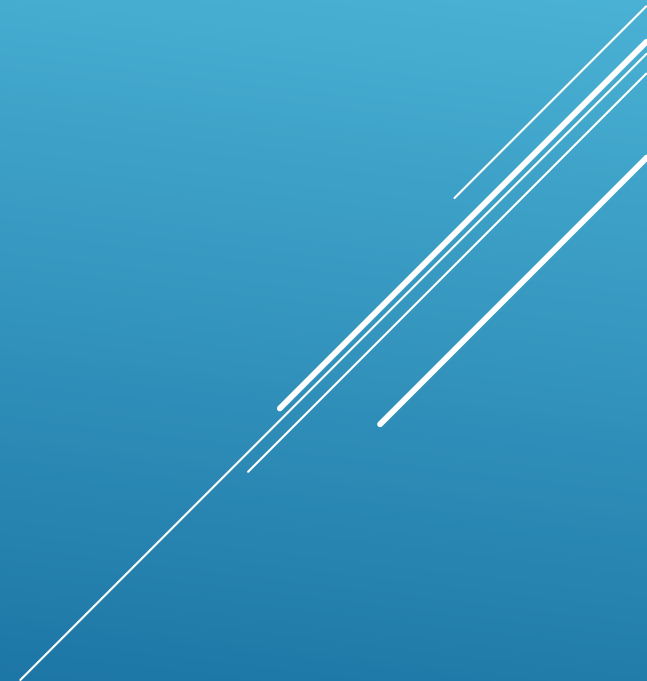

# STEADY VS. UNSTEADY

- ▶ Difference in handling boundary friction and other losses
- ▶ Difference in numerical solution algorithm
- ▶ Difference in handling non-flow areas
- ▶ Difference in flow and boundary condition data requirements
- ▶ Difference in calibration strategy
- ▶ Difference in application strategy

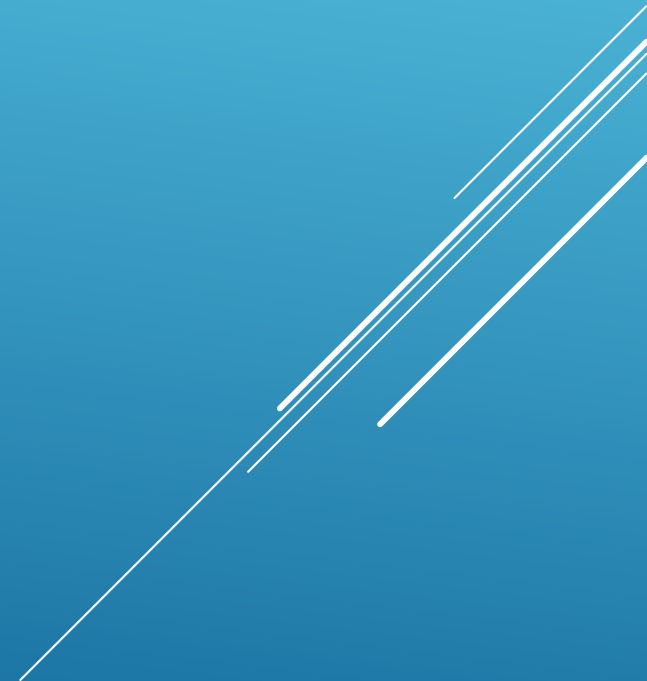

# PRE-COMPUTATION OF HYDRAULIC PROPERTIES

Steady – Compute exact hydraulic properties at a section for each trial water surface elevation from the elevation/station points, *n*-values.

Unsteady – Hydraulic properties are pre-computed for all possible water surface elevations at each cross section (hydraulic table)

# MORE TYPES OF FLOWS

## *Uniform Vs. Non-uniform flow*

- ▶ **Uniform flow** occurs if the conditions do not vary from cross section to cross section (i.e., with distance).
- ▶ **Non-Uniform Flows** implies that the flow varies in velocity with distance downstream. It is accepted that the flow is non-uniform perpendicular to the flow as well because of the boundary layers experienced on the bed and on the submerged sections of the riverbanks.

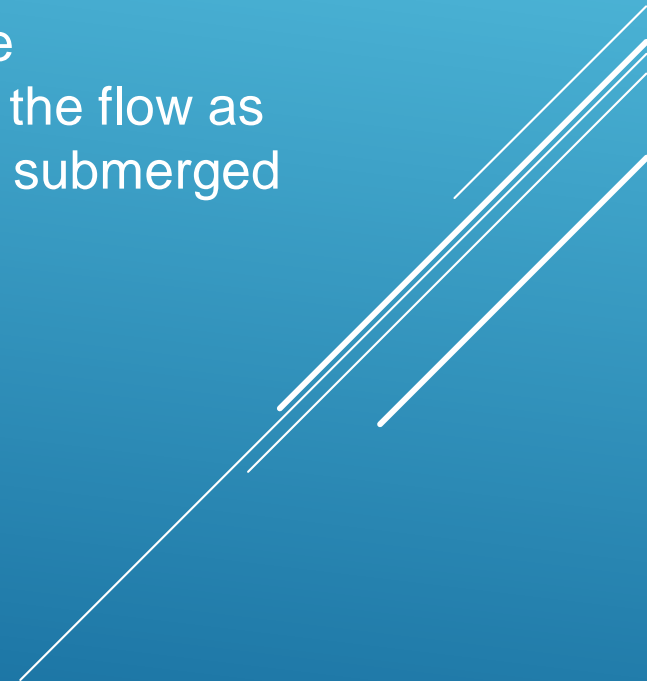

# FROUDE NUMBER

## ▶ Froude Number, Fr

The Froude number, relates the relative strength of Gravity effects and Viscous effects. This number is of use in open channel flows where a free water surface is in contact with the air. The Froude number is defined as follows,

$$Fr = \frac{V}{\sqrt{gL}}$$

where

- ▶  $V$  = flow velocity, m/s
- ▶  $g$  =gravitational acceleration, m/s<sup>2</sup>
- ▶  $L$  = characteristic length i.e. commonly the cross sectional flow area measured perpendicular to the flow divided by the river surface width in contact with the air.

# FROUDE NUMBER

## ► Sub-Critical or Tranquil flows

In sub-critical flows the denominator of equation 3 is greater than the numerator i.e. Froude number less than unity and this flow regime is referred to as the tranquil flow. The denominator clearly has dimensions of m/s and is an indication of the velocity of a shallow wave. Thus since the Froude number is less than unity the velocity of the shallow wave (celerity) is in excess of the mean flow velocity,  $V$ . This implies that a disturbance will propagate upstream against the flow of the river.

# FROUDE NUMBER

## ► Supercritical or Rapid flows

In cases of rapid flow i.e. with the Froude number,  $Fr > 1$  a shallow wave disturbance will have a lower velocity than the prevailing stream velocity. In other words this will result in the wave being unable to make headway upstream and it will be swept downstream with the flow.

# HYDRAULIC JUMP

A hydraulic jump occurs when water in an open channel is flowing supercritical and is slowed by a deepening of the channel or obstruction in the channel. The slowing causes the water to suddenly jump to the other specific energy state (slow, deep flow). One example of the formation of a hydraulic jump is at the downstream of a dam spillway

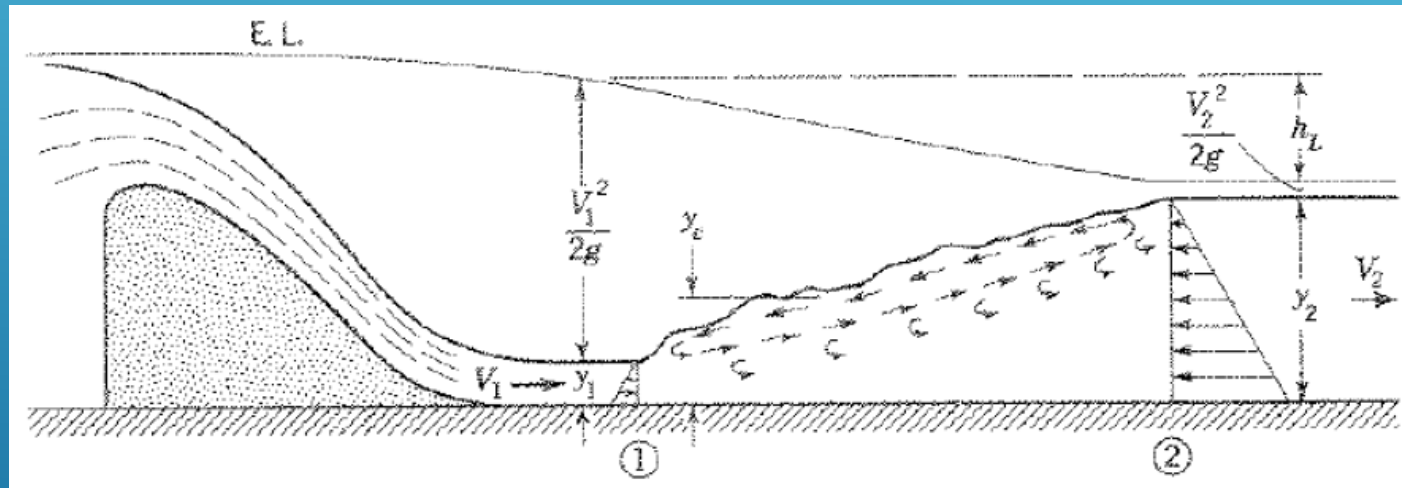

For a hydraulic jump to occur the flow before the jump must be super-critical (fast and thin) and the Froude Number must be greater than 1 ( $Fr > 1$ ).

# STEADY UNIFORM FLOW

- ▶ Steady Uniform flow occurs when the force that drives flow (gravitational) balances the opposing force (friction at the channel bottom). The flow depth when this happens is the Normal depth. The expression derived by balancing these forces is known as the now popular “Manning’s Equation” developed by Robert Manning:

$$V = \frac{1}{n} R^{2/3} S^{1/2}$$

Where

- ▶ V: Average velocity (m/s)
- ▶ n: Manning’s Number (Dimensionless) – a measure of the channel resistance
- ▶ R: Hydraulic Radius (m)
- ▶ S: Slope of the channel (Dimensionless)

# MANNING NUMBER

**Table 11.2:** Typical Manning's n values

Channel description	Manning's n
Glass, copper, plastic, or other smooth surfaces	0.01
Smooth, unpainted steel, planed wood	0.012
Painted steel, coated cast iron	0.013
Smooth asphalt, clay drainage tiles, trowel-finished concrete, glazed brick	0.013
Uncoated cast iron, wrought iron, vitrified clay	0.014
Brick in cement mortar, float-finished concrete, concrete pipes	0.015
Formed, unfinished concrete, spiral steel pipe	0.017
Smooth earth	0.018
Clean excavated earth	0.022
Corrugated metal storm drain	0.024
Natural channel – stones and weeds	0.003
Natural channel – light bush	0.05
Natural channel – tall grass and reeds	0.06
Natural channel – heavy brush	0.1



# NUMERICAL MODELLING TOOLS

# FLOOD INUNDATION MODELLING

- ▶ Model types are classified according to their dimensionality.
- ▶ The most significant ones are the 1D, Quasi2D and 2D methodologies.
- ▶ Three-dimensional numerical models are also available
- ▶ All the numerical model types are based on the same Navier-Stokes equation, and the dimensionality depending on that equation is integrated.

# ONE-DIMENSIONAL MODELS

- ▶ One-dimensional models are based on some form of the one-dimensional St-Venant or shallow water equations, which can be derived by integrating the Navier-Stokes equations over the cross-sectional surface of the flow.
- ▶ The assumptions used in the derivation of the St-Venant equations limit their use to where the direction of water movement is aligned to the centre line of the river channel.

# ONE-DIMENSIONAL MODELS

- ▶ The 1D approach poses two main issues:
  1. Floodplain flow is assumed to be in one direction parallel to the main channel, which is often not the case
  2. The cross-sectional averaged velocity predicted by the St-Venant has a less tangible physical meaning in a situation where large variations in velocity magnitude exist across the floodplain.
  
- ▶ In the other hand, one of the principal strengths of 1D river models is their capability to simulate flows over and through a large range of hydraulic structures such as weirs, gates, sluices and so on.

# ONE-DIMENSIONAL MODELS

## ► Steady flow

The steady flow computation uses the continuity equation and an equation for the friction loss to compute the velocity and location of the water surface. Manning's formula is most commonly used.

The computation starts with measuring the geometry of a number of cross-sections in the river. The distance and elevation of a number of points in the cross-sections are recorded. The distances between the cross-sections are also measured.

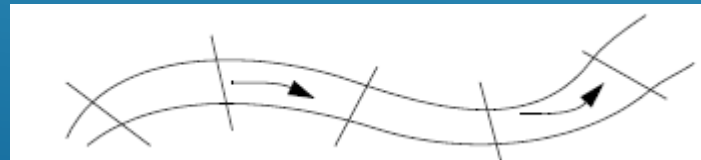

# ONE-DIMENSIONAL MODELS

## ► Steady flow

For each section, a curve is made with the wetted area as a function of the water level. This curve is used in the following computations.

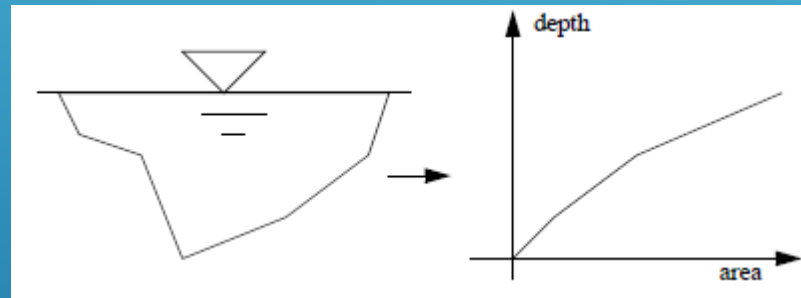

The computation of the water elevation usually starts with a given value downstream, as this is the controlling value for subcritical flow. Then the water elevation of the upstream cross-section is to be found.

# ONE-DIMENSIONAL MODELS

- ▶ Unsteady flow

The one-dimensional water flow is governed by the Saint-Venant equations

Computation of discharge and water level is carried out in every cross section.

Stability issues.

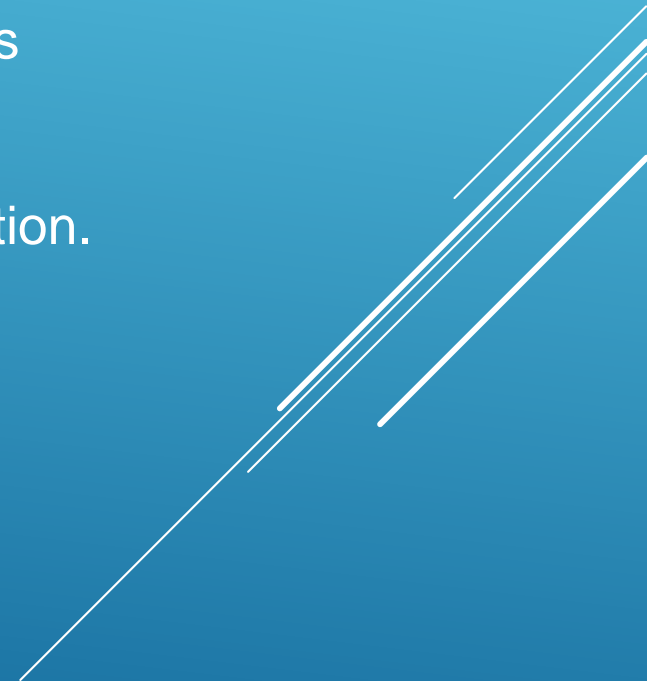

# TWO-DIMENSIONAL MODELS

- ▶ Two-dimensional hydrodynamic numerical models are based on the two-dimensional shallow water equations (SWE). The SWE can be derived by integrating the Reynolds-averaged Navier-Stokes equations over the flow depth.
- ▶ Hydrostatic pressure distribution is assumed.
- ▶ A solution to these equations can be obtained from a variety of numerical methods (such as **finite difference, finite element or finite volume**) and use different numerical grids (**such as Cartesian or boundary fitted, structured or unstructured**) all of which have advantages and disadvantages in the context of floodplain modelling.

# TWO-DIMENSIONAL MODELS

- ▶ A structured grid is a grid that can be conceptually represented on a rectangular matrix. Structured square grids have an obvious advantage over unstructured grids in that the construction of the physical geometry of the grid is straightforward and entirely defined by a small number of user-defined parameters, for example resolution, lower left corner coordinates, and dimensions

# TWO-DIMENSIONAL MODELS

- ▶ An unstructured grid is a grid that cannot be represented on a rectangular matrix. The main strength of unstructured grid models lies in the possibility to follow irregular floodplain contours, and to apply a non-uniform resolution. It can be refined locally to take into account fine features in the flow, while keeping a low resolution in areas where refinement is not needed, thereby ensuring optimal use of computer power. However, the finer areas usually dictate that a smaller time step be used which can increase computation time.

# ADVANTAGES OF 3D MODELLING

- ▶ Simplifies modelling
  - ▶ Artificial approximations or simplifications are not needed
  - ▶ Makes model set-up and calibration significantly easier
- ▶ Corresponds directly to real physical processes
- ▶ Improves considerable modelling accuracy



# ADVANTAGES OF 3D MODELLING

- ▶ Makes possible the modelling of (i.e.):
  - ▶ Stratification
  - ▶ Vertical turbulence
  - ▶ Irregular vertical flow and concentration profiles
  - ▶ Flow within and above vegetation
  - ▶ Irregular near-bottom and near-surface processes
  - ▶ Return flow
- ▶ Especially appropriate for sediment modelling
- ▶ Does not require more data than 2D-modelling
- ▶ Natural description of river profiles
- ▶ Additional need of computation power is reasonable



# COUPLED 1D-2D MODELS

A number of commercial software packages include the possibility to link a 1D river model to 2D floodplain grids. This has become popular in recent years because it allows the modeller to take advantage of the established tradition of 1D river modelling while at the same time modelling floodplains in two dimensions. This also results in computational savings over structured fully 2D approaches where a finer grid would be required to correctly represent the river channel geometry.

# COUPLED 1D-2D MODELS

Several techniques exist to date to link 1D and 2D models. The most widely used technique for 1D river and 2D floodplain linking is the lateral link, where the exchange flows are typically modelled using broad crested weir equations or depth-discharge curves, based on water level differences. A limitation of the approach is that the complicated momentum exchange processes that characterise the river-floodplain boundary are not modelled (due to the fact that these processes intimately depend on complex 3D flow patterns in the river, which by definition are not resolved in a 1D river model).

# COUPLED 1D-2D MODELS

Other linking approaches include the longitudinal link, which one may use to model a watercourse partly in 1D (upstream) and partly in 2D (downstream), or to connect the downstream extremity of a 1D model to a 2D grid. In this approach the flow from the 1D enters the 2D model as a “source”, and the water level in the 2D model at the junction is used as a downstream boundary condition in the 1D model. Some combined 1D+2D models also offer the possibility to use small 1D components to represent pipes or culverts within an otherwise 2D model.

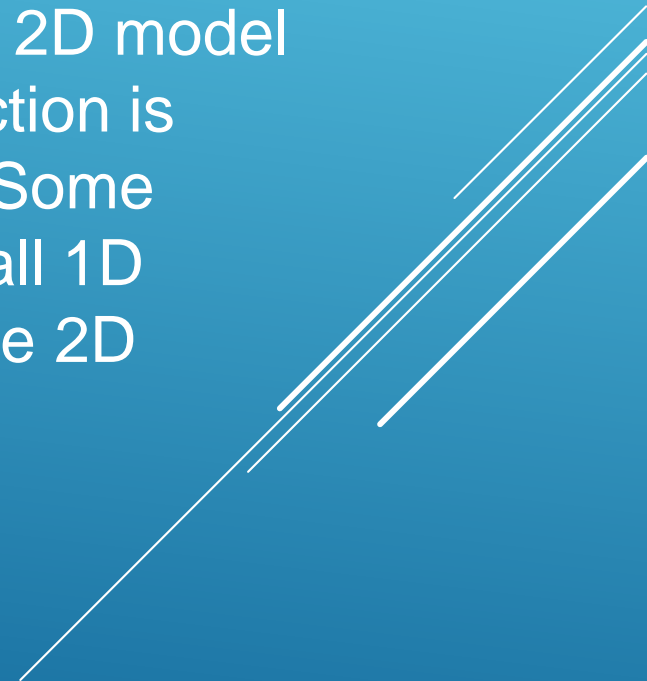

# HOW TO CHOOSE A NUMERICAL MODELLING TOOL

The choice between a 1D or 2D (or 1D+2D) model is relevant primarily in the context of river floodplain modelling.

One-dimensional models are appropriate for narrow floodplains, typically where their width is not larger than three times the width of the main river channel. The underlying assumption should be that the contribution of the floodplains to conveyance can be quantified using recent advances in the estimation of compound channel conveyance.

An additional condition for such models to be valid is that the floodplains should not be separated from the main channel by embankments, levees or any raised ground, where the channel floodplain unit effectively behaves as a single channel.

# HOW TO CHOOSE A NUMERICAL MODELLING TOOL

One-dimensional river models have limitations that can become significant in many practical applications.

The flow is assumed to be unidirectional (generally happening in the direction parallel to the main channel flow), and where this is not true (recirculation areas) conveyance predictions can be severely overestimated.

Situations where floodplain flow “makes its own way” are frequent, but perhaps an even more significant issue is the fact that 1D cross-sections will offer a rather crude representation of floodplain storage capacity in the case of large floodplains.

# HOW TO CHOOSE A NUMERICAL MODELLING TOOL

2D modelling of river floodplains can itself be divided into two important classes of approaches, namely the one where only floodplains are modelled in 2D (as part of a combined 1D+2D model) and the one where floodplain flow and channel flow are modelled as part of the same 2D grid.

The main advantage of 2D modelling (over any other approach for floodplain modelling) is that local variations of velocity and water levels and local changes in flow direction can be represented.

# HOW TO CHOOSE A NUMERICAL MODELLING TOOL

The approach does not suffer from the limitations of the 1D. It allows in principle a better representation of floodplain conveyance, but a major limitation of combined 1D+2D models for river and floodplain systems is that the exchange processes between the river and the floodplains are still modelled crudely (momentum transfer is not modelled).

A major drawback of 2D models is their computational cost. Thus, the approach where the whole river and floodplain system is represented as part of a 2D unstructured grid deserves special attention.

Mode	Advantages	Disadvantages
1D	<ul style="list-style-type: none"> <li>• Accurate hydraulic description in rivers/channels which are one-dimensional flow;</li> <li>• Less computational points relative to 2D model;</li> <li>• Easy to analyse and extract results.</li> </ul>	<ul style="list-style-type: none"> <li>• Flow paths must be known beforehand;</li> <li>• Substantially more effort required for model schematisation</li> <li>• Depth and width averaged flow; no detailed flow descriptions in floodplains</li> </ul>
2D	<ul style="list-style-type: none"> <li>• 2D flow simulated dynamically without prescribing flow patterns;</li> <li>• Flexibility for tailoring grid resolution within the model (unstructured grids);</li> <li>• Detailed information on velocity, depths etc. on floodplains;</li> </ul>	<ul style="list-style-type: none"> <li>• Requires fine grid in rivers/channels in order to define conveyance accurately.</li> <li>• Requires more computational effort than 1D engine</li> </ul>
1D+2D	<ul style="list-style-type: none"> <li>• Contains the benefits from both 1D and 2D Engines</li> <li>• Integration of floodplains, rivers and coasts systems</li> <li>• Visual presentation of flood results</li> <li>• Allows sub-grid scale features (hydraulic structures) to be accurately represented</li> </ul>	<ul style="list-style-type: none"> <li>• Two models must be maintained instead of one;</li> <li>• Computational effort</li> </ul>

# HOW TO CHOOSE A NUMERICAL MODELLING TOOL

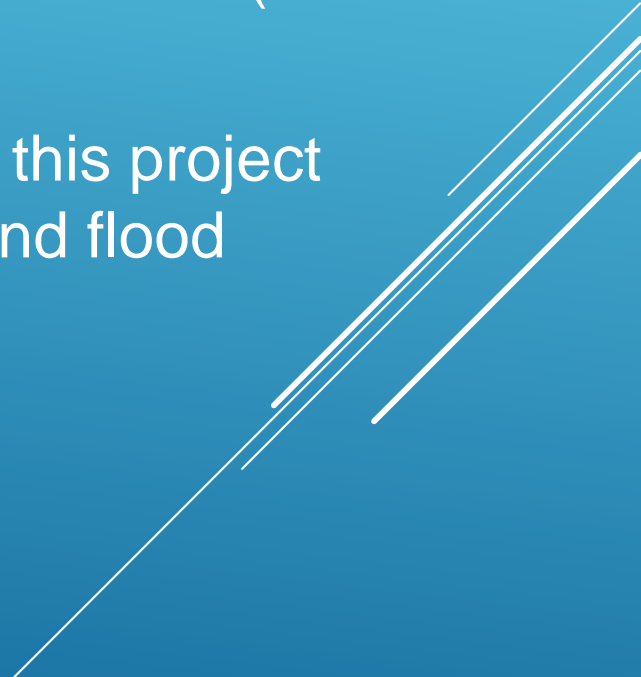
- ▶ There are some key questions to consider before choosing a type of numerical model, such as what are the phenomena to study, or the required results, the study area or the available data and resources (time and budget).
  - ▶ The main objectives concerning the hydraulic modelling for this project are flood hazard mapping, flood vulnerability assessment and flood mitigation options.
- 



# MODEL IMPLEMENTATION – 1D

# BEFORE YOU START... LAYOUT THE MODEL

- ▶ Extent of study area
- ▶ Area of interest
- ▶ Boundary conditions
- ▶ Section locations and orientation



# GEOMETRY DATA - THE BASICS

- ▶ Cross-section information
- ▶ Roughness coefficients
- ▶ Distance between sections
- ▶ Bridge/culvert data

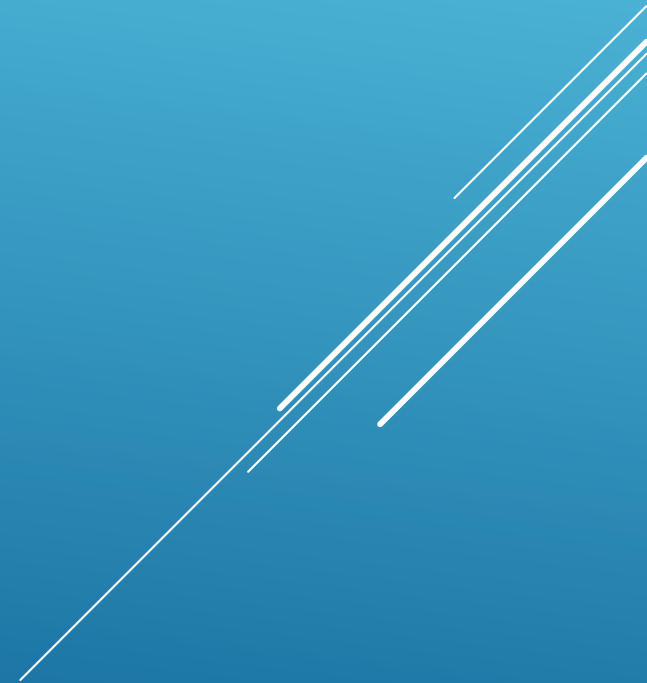

# CROSS SECTION LOCATIONS

A changes in:

- ▶ Slope
- ▶ Discharge
- ▶ Roughness
- ▶ Channel shape
- ▶ Control (bridge, levee, weir, etc)

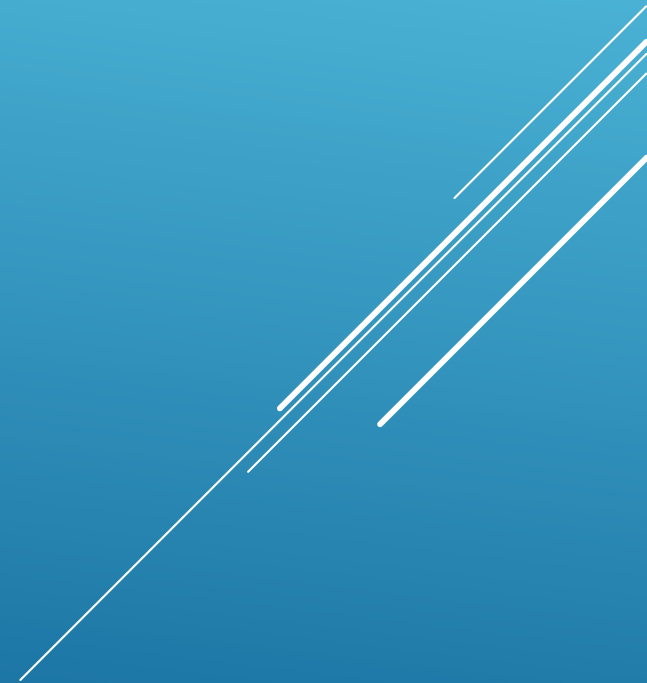

# CROSS SECTION ORIENTATION

- ▶ Survey perpendicular to flow
- ▶ May not be a straight line

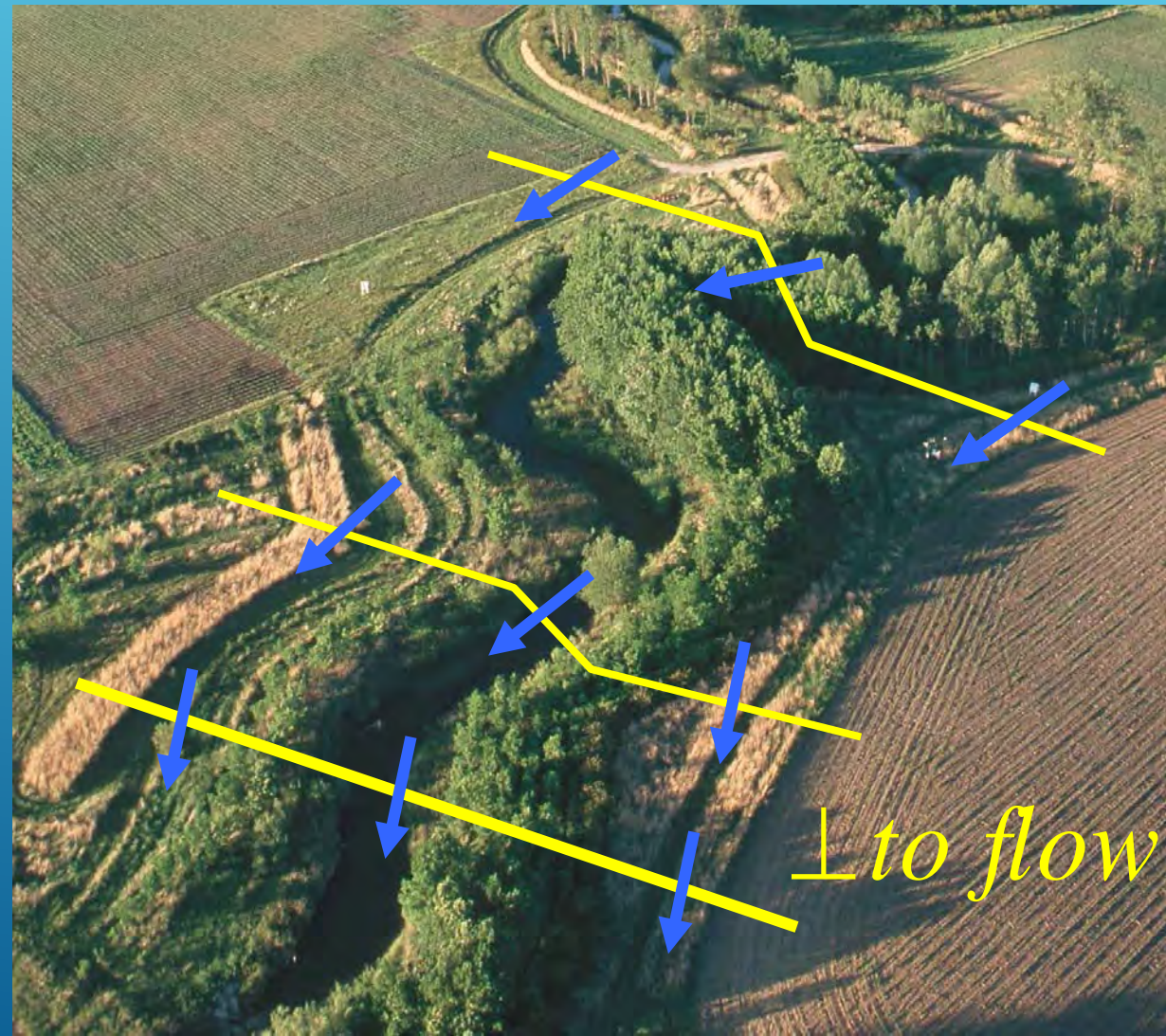

# CROSS SECTION SPACING

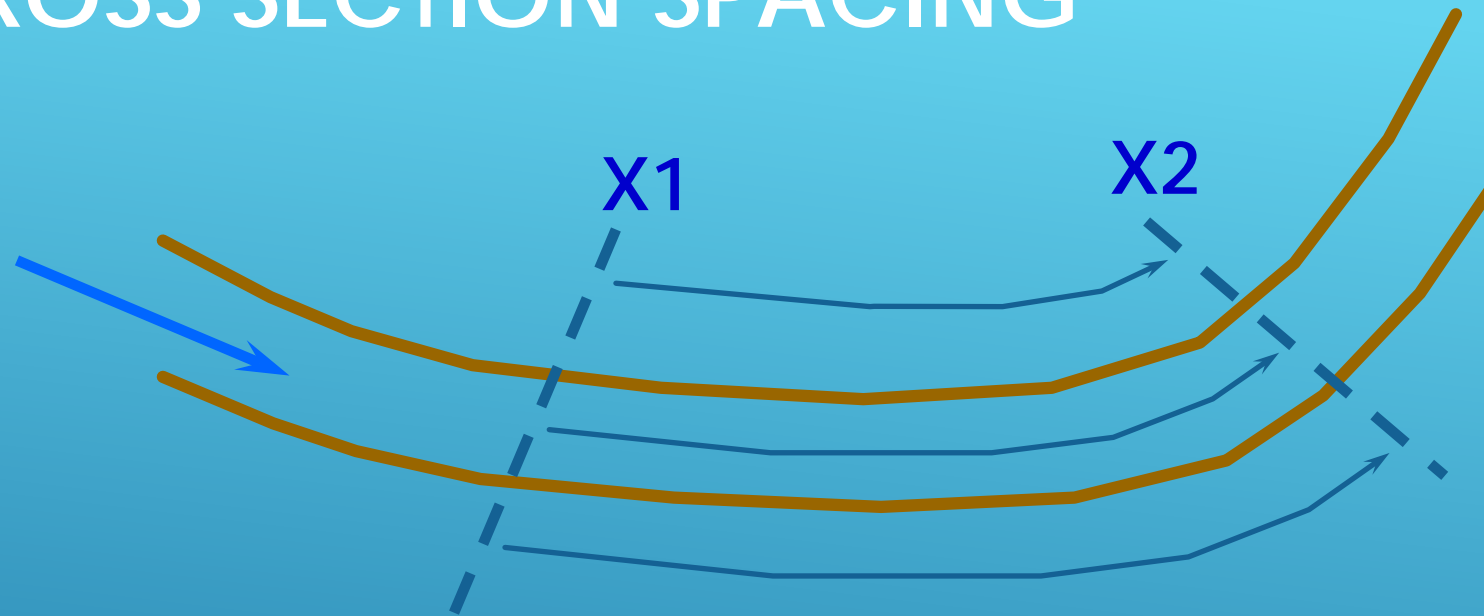

In general:

- Widely spaced for flat, very large rivers and closer for steep small streams
- Very large rivers (Mississippi) on the order of a mile
- For large rivers on the order of 1000 feet
- For slower streams on the order of 200 feet
- For small creeks on the order of 25 feet
- For supercritical reaches, on the order of 10 to 50 feet
- For drop structures, as low as 5 feet
- Can interpolate if reasonable (check results)
- Not too close (1', may drop friction losses)

# Reach Lengths - Are they constant?

High flow  
Low flows

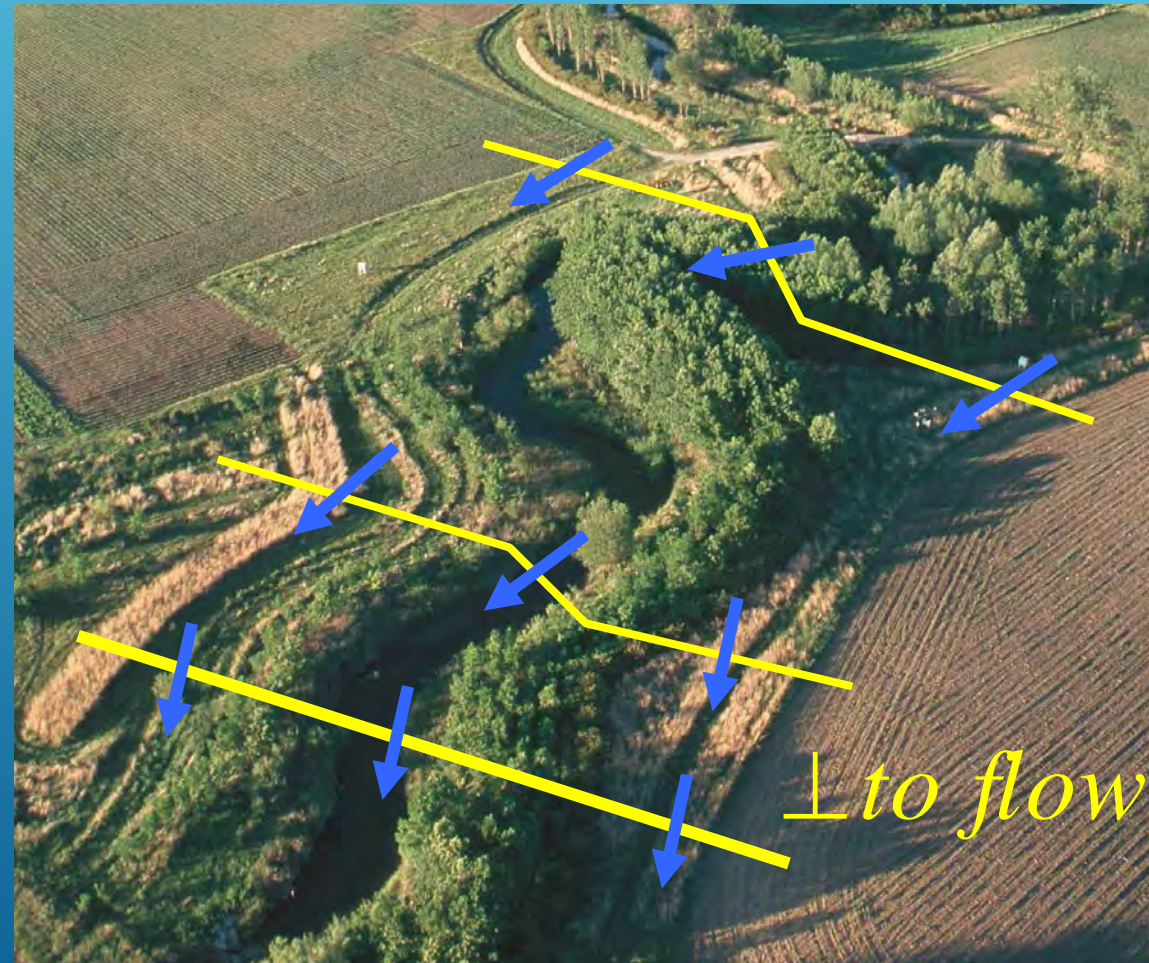

# SURVEY

- ▶ Survey shots must describe the channel and overbank flow area
  - ▶ Section should extend across the entire floodplain
  - ▶ Plot cross-section data, especially electronic surveys
  - ▶ Take photographs
  - ▶ Assume modeler has never seen the stream
  - ▶ Note vegetation changes in cross-section e.g. field, trees, grass buffer, etc.
  - ▶ No 3-point cross-sections
- 

# BRIDGE SURVEYS

- Profile road and bridge deck centerline
- Pier width, location
- Low Chord Elevation
- Skew Angle (bridge - stream)
- Bridge opening

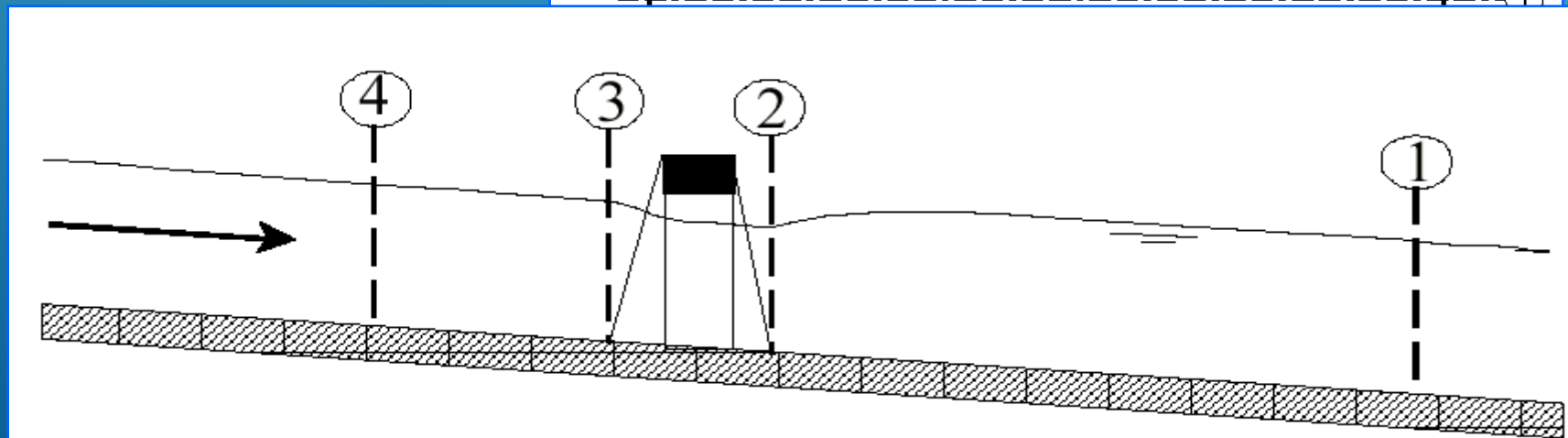
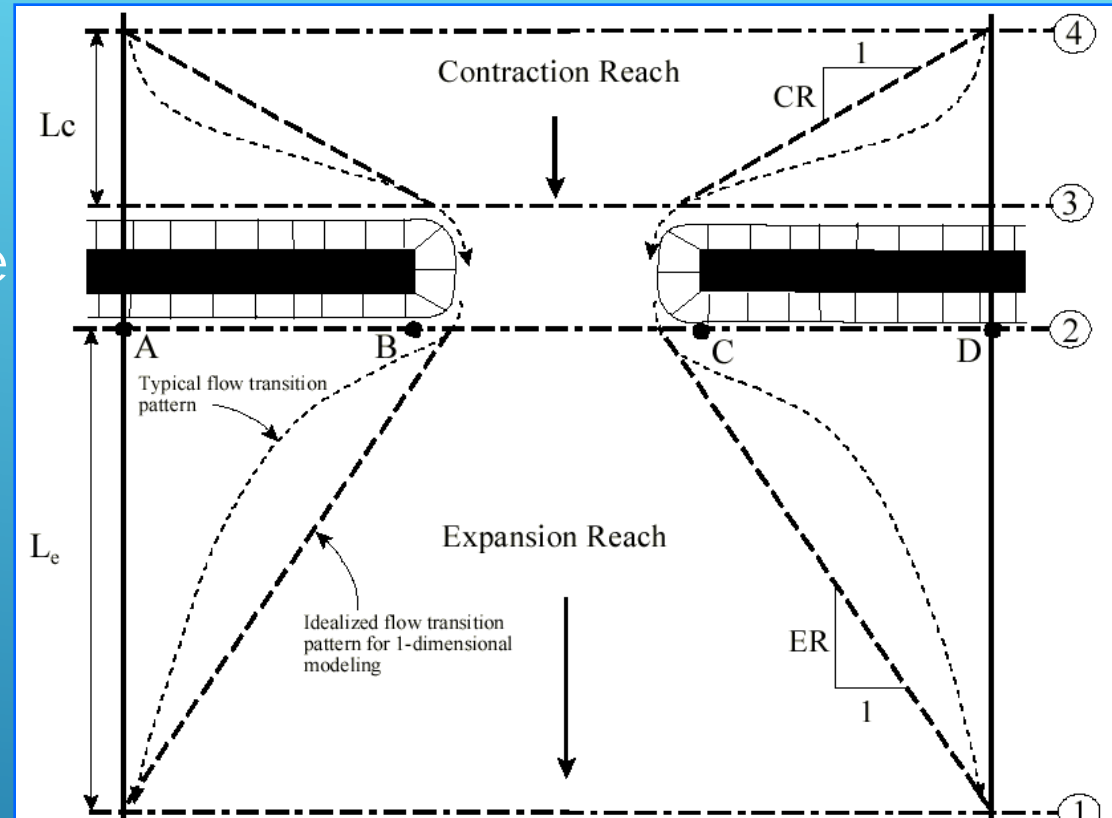

# INDEX – MODEL BUILD 1D

1. CREATING THE PROJECT FILE
2. DEFINE THE PROJECT PROJECTION
3. DEFINE GEOMETRY FILE
4. DEFINE THE BOUNDARY CONDITIONS
5. RUN THE MODEL
6. EXAMINE THE RESULTS

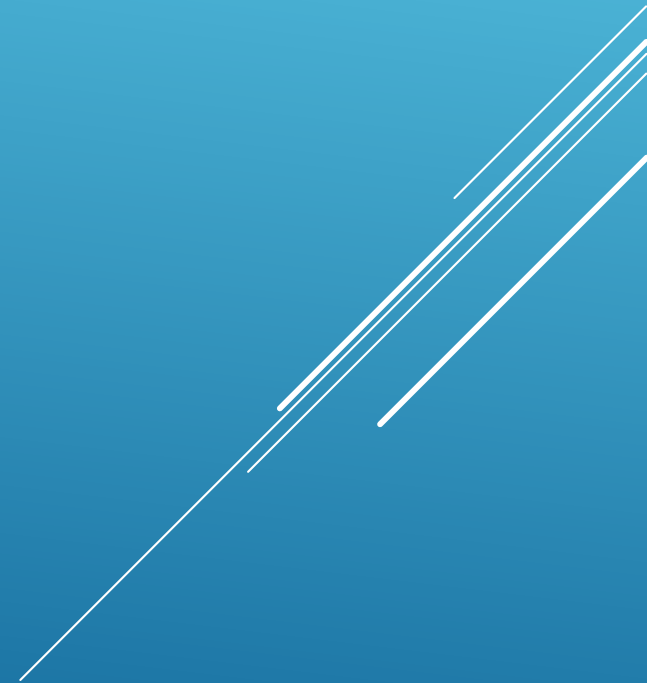

# BUILDING A MODEL

The image shows the HEC-RAS 5.0.0 software interface with various tool icons and descriptive text boxes. The interface includes a menu bar (File, Edit, Run, View, Options, DSS Tools, Help), a toolbar with icons for file operations, simulation, and analysis, and a project information table.

Project:	Bald Eagle Creek Example Dam Break Study	File	HEC Data\HEC-RAS\Unsteady Examples\BaldEagleDamBrk.prj
Plan:	PMF - Froehlich Breach Parameters	Edit	HEC Data\HEC-RAS\Unsteady Examples\BaldEagleDamBrk.p06
Geometry:	Existing GIS Data for Dam Break	Run	HEC Data\HEC-RAS\Unsteady Examples\BaldEagleDamBrk.g02
Steady Flow:		View	
Unsteady Flow:	PMF Event from HMS	Options	HEC Data\HEC-RAS\Unsteady Examples\BaldEagleDamBrk.u02
Description:	The United States Army Corps of Engineers has granted access to the information in this	DSS Tools	HEC-RAS 5.0.0

US Customary Units

**Unsteady Flow Data:** Edit and/or enter unsteady flow data

**Unsteady Flow Analysis:** Perform an unsteady flow simulation

**XYZ Perspective Plot:** View 3D multiple cross section plot

**Open Project:** Open an existing project

**Water Quality Data:** Enter and edit water quality data

**Cross Sections:** View cross section plots

**Hydraulic Properties:** Plots and tables of hydraulic properties

**Geometric Data:** Edit and/or enter geometric Data

**Water Quality Analysis:**

**General Profile Plot:** View computed variables along the channel

**Profile Summary Table:** View summary output at multiple locations by profile

**View DSS:** View Data stored in DSS

**Save Project:** Save an existing project

**Sediment Data:** Enter/edit sediment data

**Sediment Analysis:** Perform Sediment Transport Analysis

**RAS Mapper:**

**Rating Curve:** View computed rating curves

**Sum Errs, Warn, Notes:** Summary of Errors, Warnings, and Notes

**Steady Flow Data:** Edit and/or enter steady flow data

**Hydraulic Design Functions:** Perform hydraulic design computations

**Profile Plot:** View water surface profile plots

**Detailed Output Table:** View detailed output at cross-sections, bridges, culverts, etc...

**Steady Flow Analysis:** Perform a steady flow simulation

**Stage and Flow Hydrographs:** Plot stage and flow hydrographs

# BUILDING A MODEL

Start New Project continued..

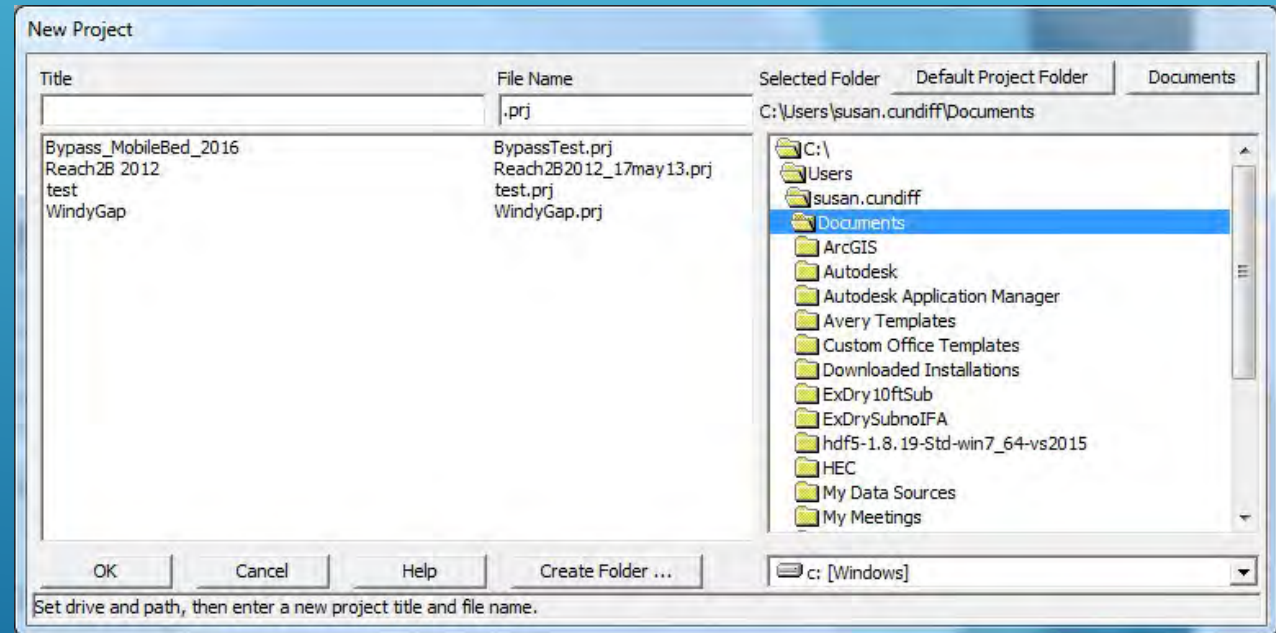
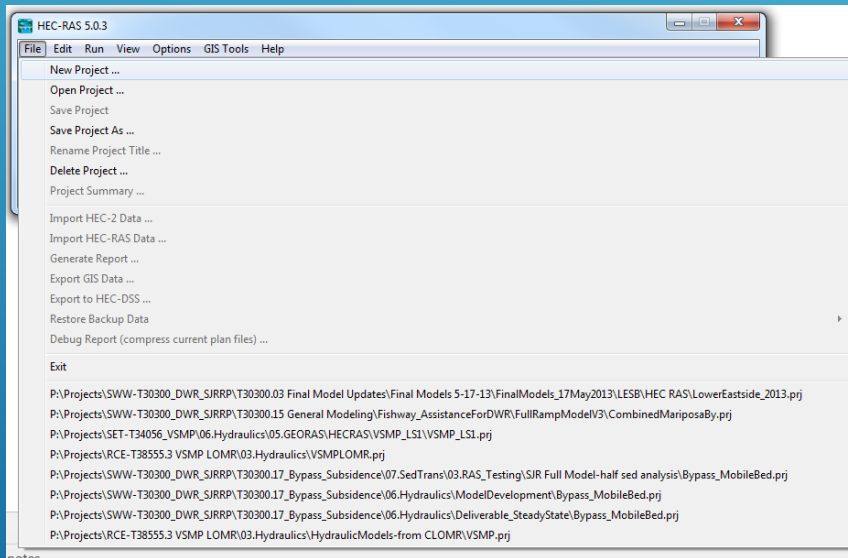

# BUILDING A MODEL

## Create New Geometry

- ▶ Import geometry data
- ▶ CAD/GIS program
- ▶ RAS Mapper

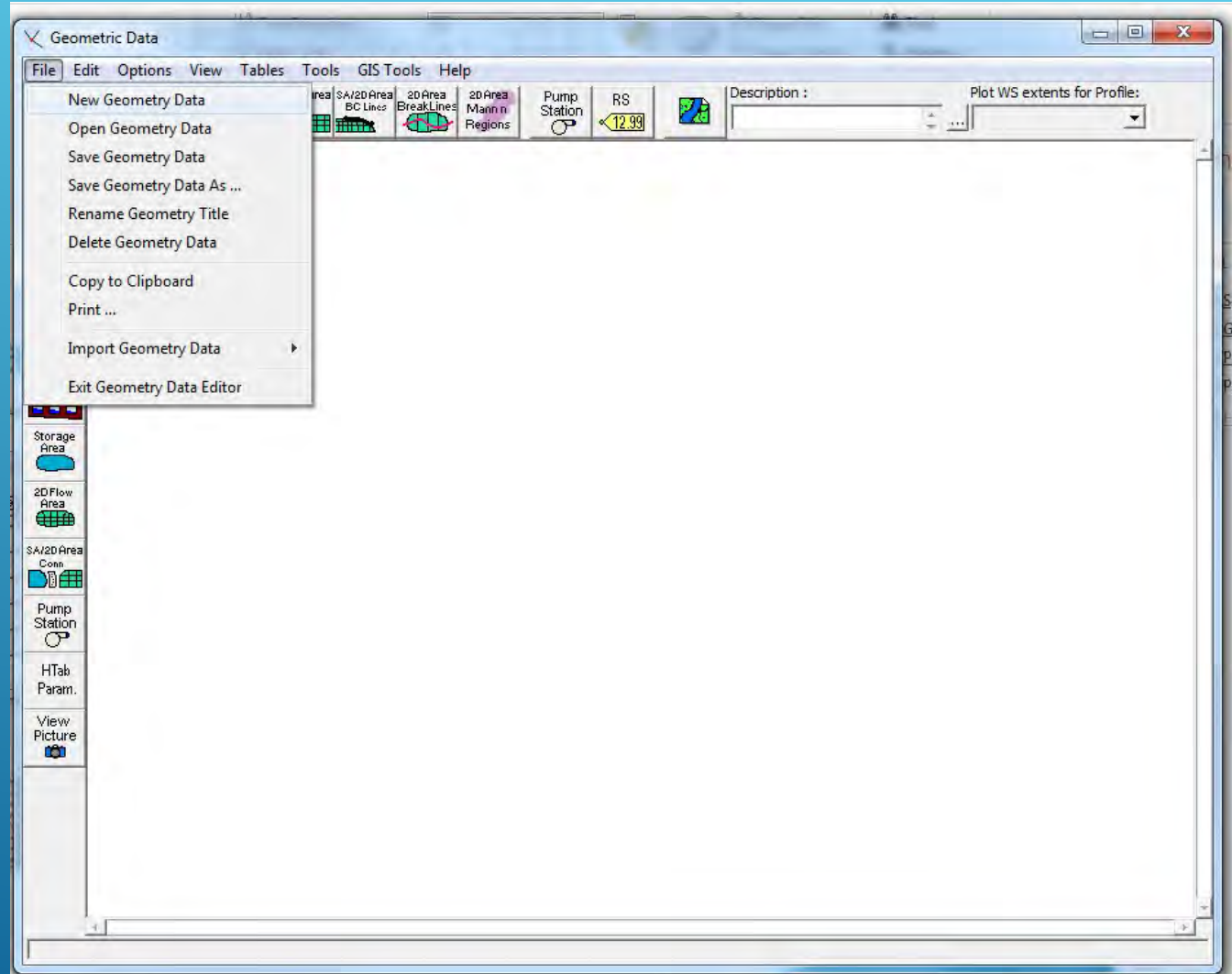

# BUILDING A MODEL

## ► Editing Geometry

- Bank Stations
- Levees
- Ineffective Flows
- Blocked Obstructions
- Mannings n-values
- Reach Lengths
- Coefficients

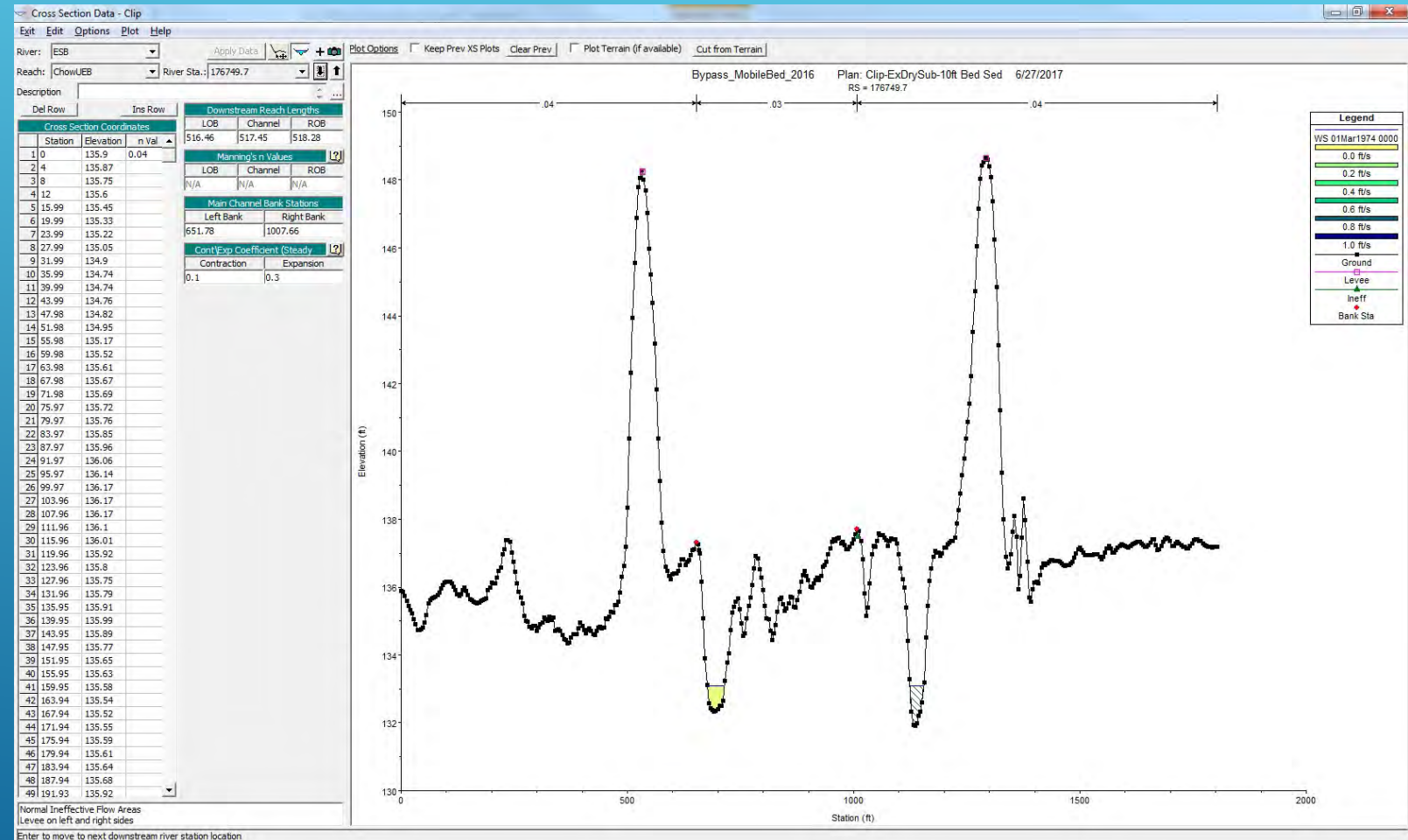

# BUILDING A MODEL

## Defining Hydrology

### ▶ Boundary Conditions

- ▶ Normal Depth
- ▶ Known WSEL
- ▶ Critical Depth
- ▶ Rating Curve

Steady Flow Data

File Options Help

Enter/Edit Number of Profiles (32000 max): 3 Reach Boundary Conditions ... Apply Data

Locations of Flow Data Changes

River: Fall River Add Multiple...

Reach: Lower Reach River Sta. 9.6 Add A Flow Change Location

Flow Change Location			Profile Names and Flow Rates			
	River	Reach	RS	PF 1	PF 2	PF 3
1	Fall River	Upper Reach	10	500	2000	5000
2	Fall River	Lower Reach	9.79	600	2500	6500
3	Fall River	Lower Reach	9.6	650	2700	7000
4	Butte Cr.	Tributary	0.2	100	500	1500

Enter to edit the boundary conditions

# BUILDING A MODEL

## ► Defining Hydrology Continued

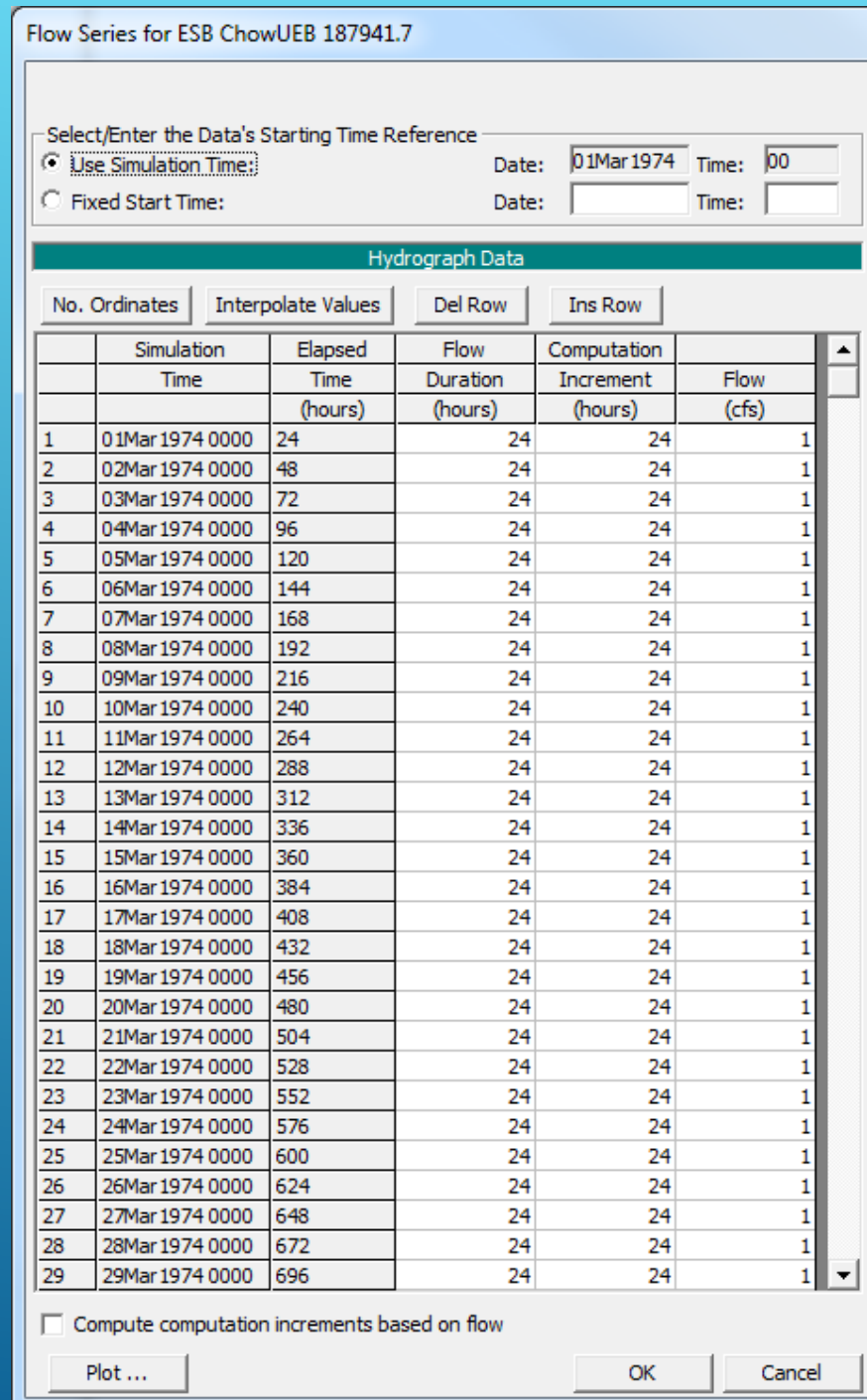
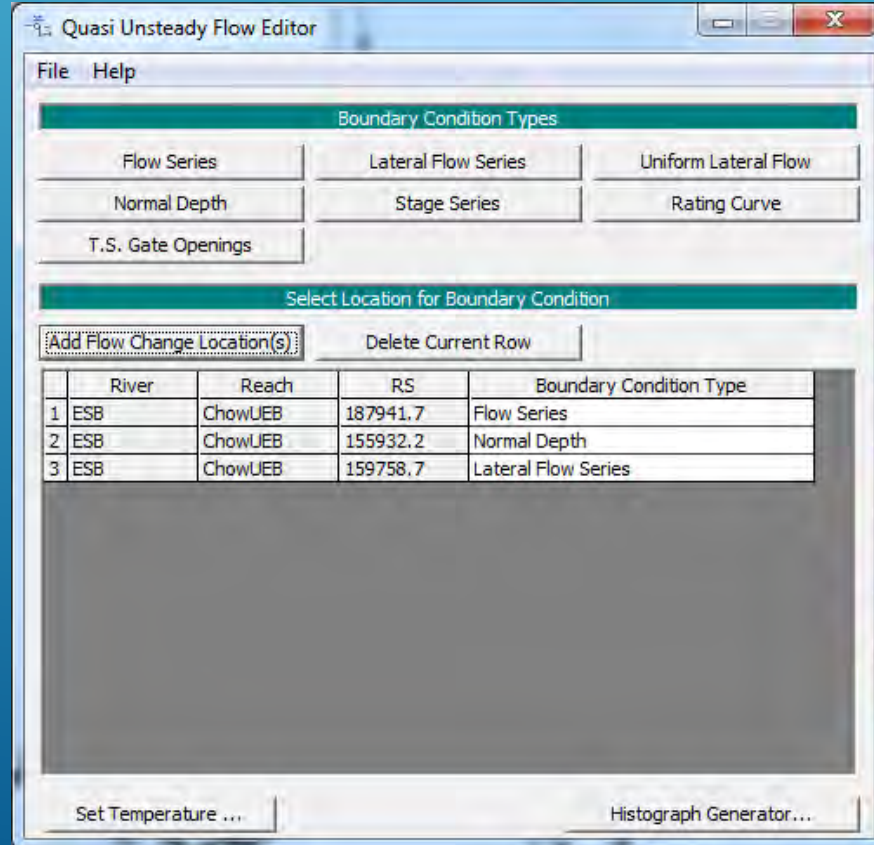

# EXECUTING A MODEL

Build your Plan

- ▶ Geometry
  - ▶ \*.g0x
- ▶ Hydrology
  - ▶ Steady: \*.f0x
  - ▶ Unsteady: \*.u0x
  - ▶ Quasiunsteady: \*.q0x
- ▶ Sediment Data
  - ▶ \*.s0x

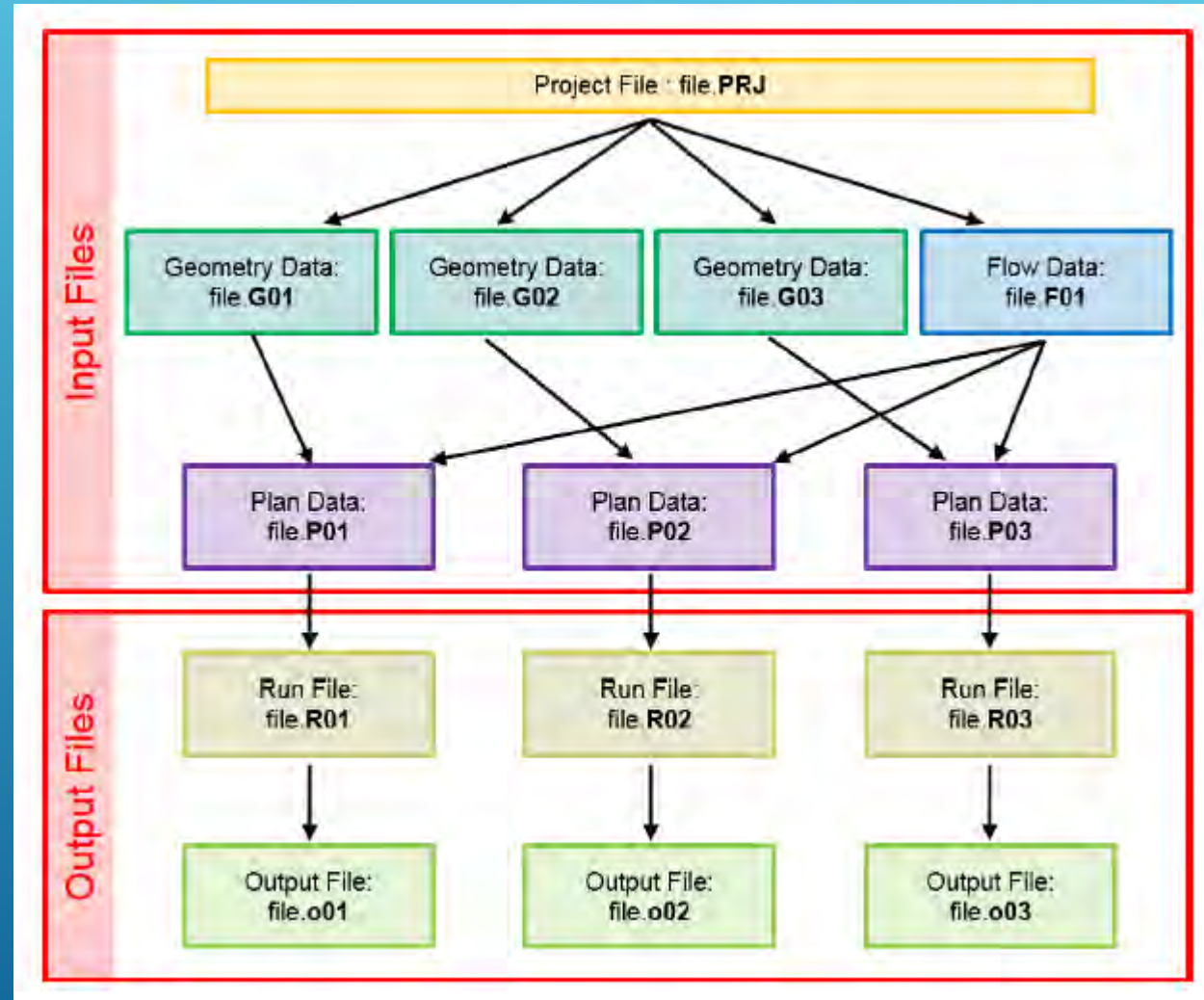

# EXECUTING A MODEL

- ▶ Options Define
  - ▶ Methods
    - ▶ Conveyance Calculations
    - ▶ Frictions Slope Methods
    - ▶ Critical Depth Calc
  - ▶ Tolerances
    - ▶ Number of iterations
    - ▶ WS Calcs
    - ▶ Sediment Transport

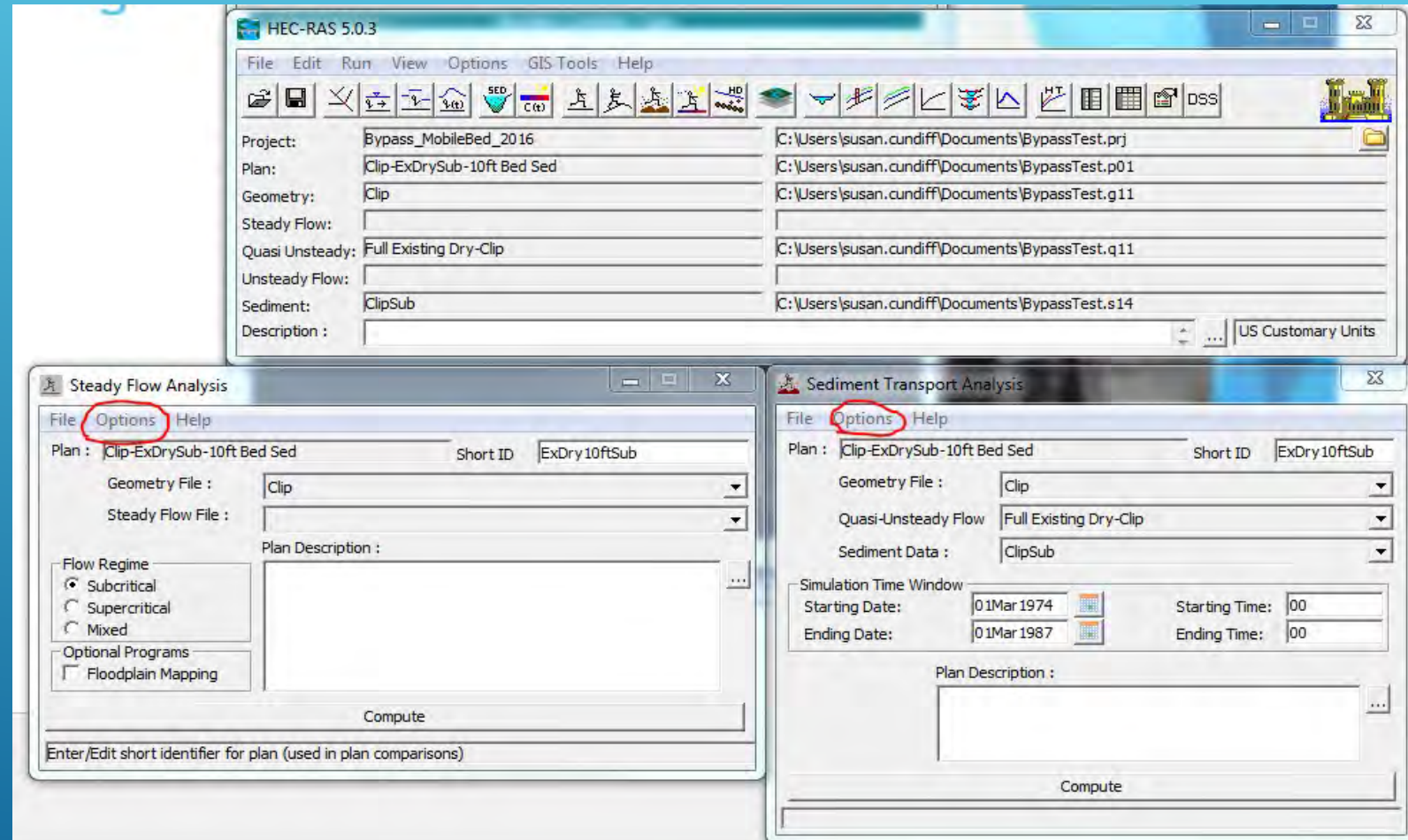

# GEOMETRY DATA



Suggested order of data entry:

Add River Reach(es) along with any Junctions (actually, this must be first).

Add Cross-Section names, elevation-station data, 'n' values, bank stations, reach lengths, loss coefficients, etc.

Add Road/Bridge/Culvert and/or Weir/Spillway data.

- ▶ Must be added before any other features
- ▶ Draw and connect the reaches of the stream system.
- ▶ Draw from upstream to downstream, which will coincide with a flow direction arrow - generally from top of screen to bottom. Double click on last point to end.
- ▶ Connection of 3 reaches is a junction.
- ▶ Can model from single reach to complicated networks. The river can even split apart and then come back together
- ▶ Can accentuate by adding background bitmap.



To add a River Reach, select the River Reach button from the Cross-Section Editor Window:

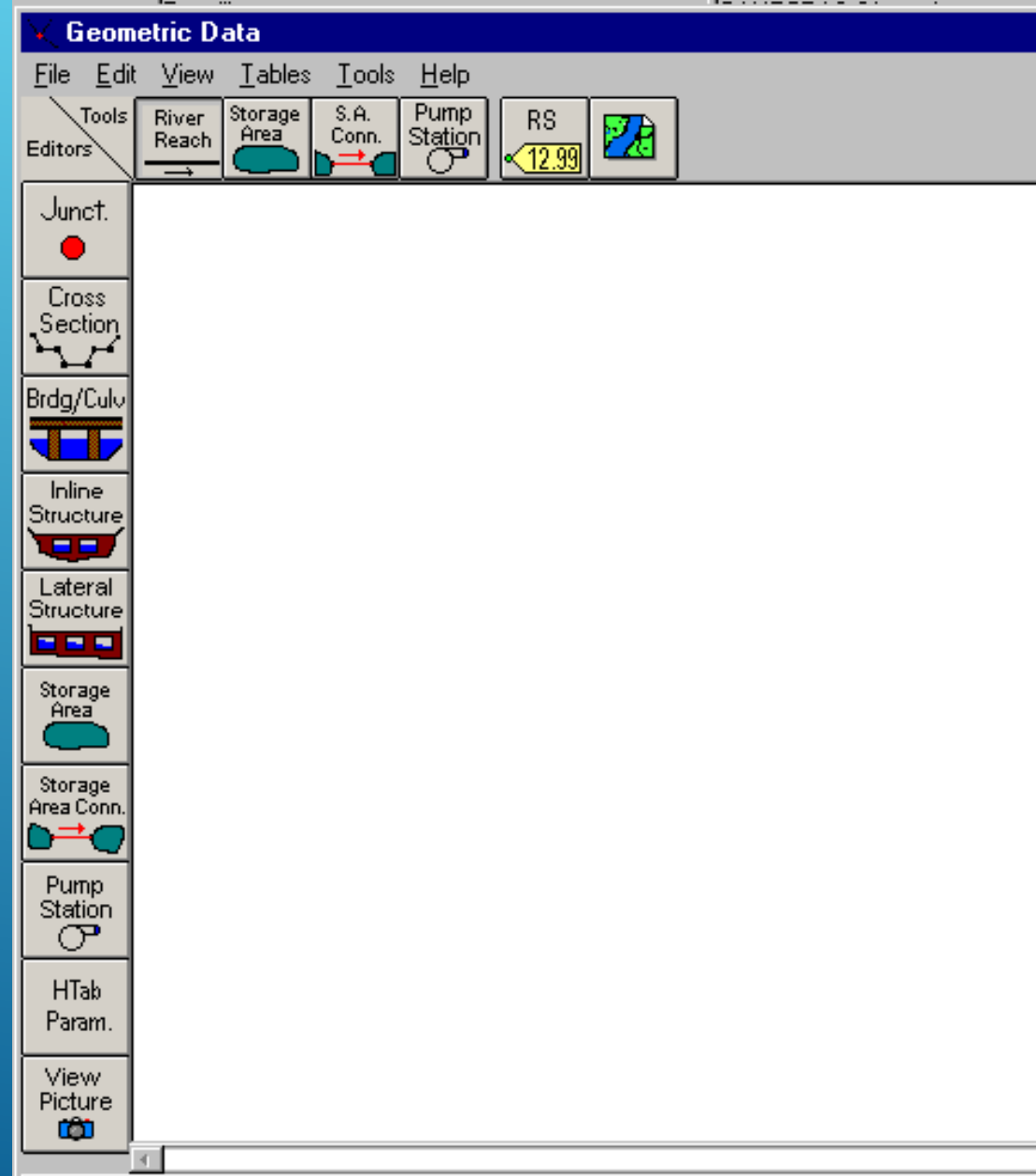

Then add line(s) representing the schematic of the river(s) you are modeling. Single click between each segment of the line. After your last line segment, double click to end:

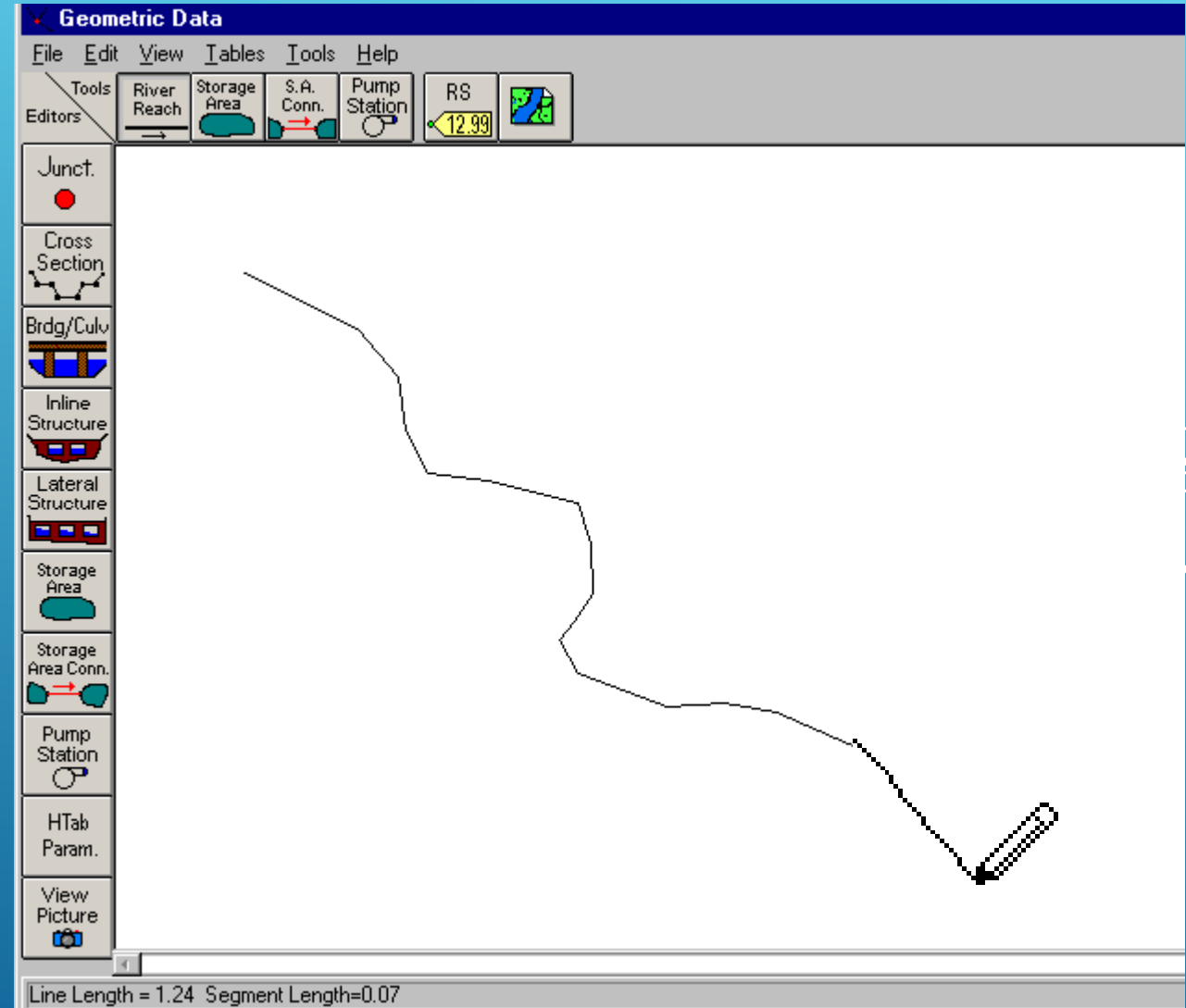

A window then pops up to allow you to enter the River name and the Reach name:



The dialog box has a dark blue title bar with a close button (X) in the top right corner. The main area has a green background with white text that reads: "Select existing River or enter a new River name (16 Char Max), and enter Reach name (16 Char Max)." Below this text are two input fields. The first is labeled "River:" and is a dropdown menu with a small downward arrow on the right side. The second is labeled "Reach:" and is a standard text input field. At the bottom of the dialog box are two buttons: "OK" and "Cancel".

The program then displays the river and its name in blue. The reach name is in black.

Tributaries and/or additional reaches can be added to the main reach using the same procedure.

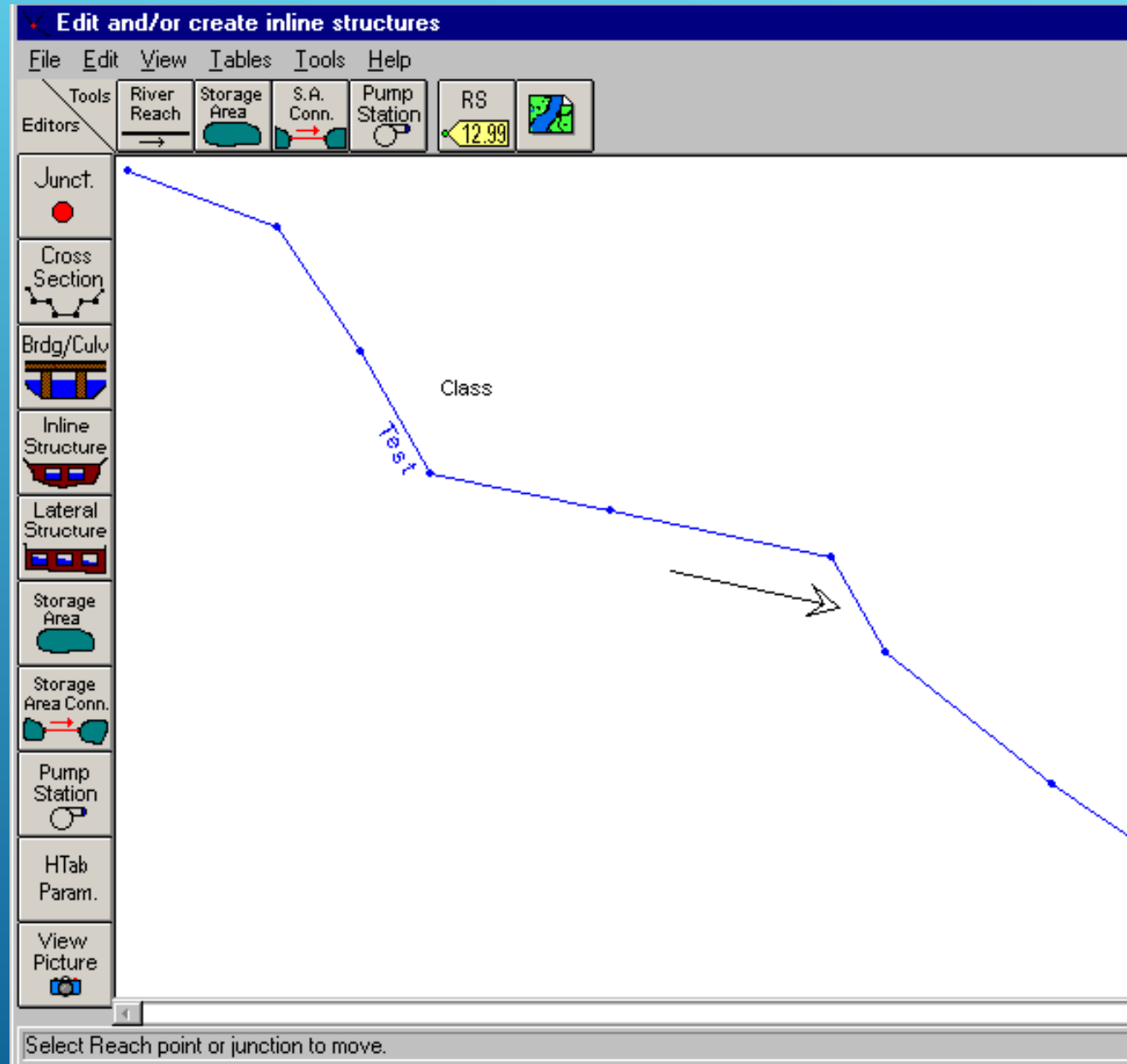

# ADDING CROSS SECTIONS TO REACHES

To add cross-section data, click on the "Cross-Section" button from the Geometry Data Window

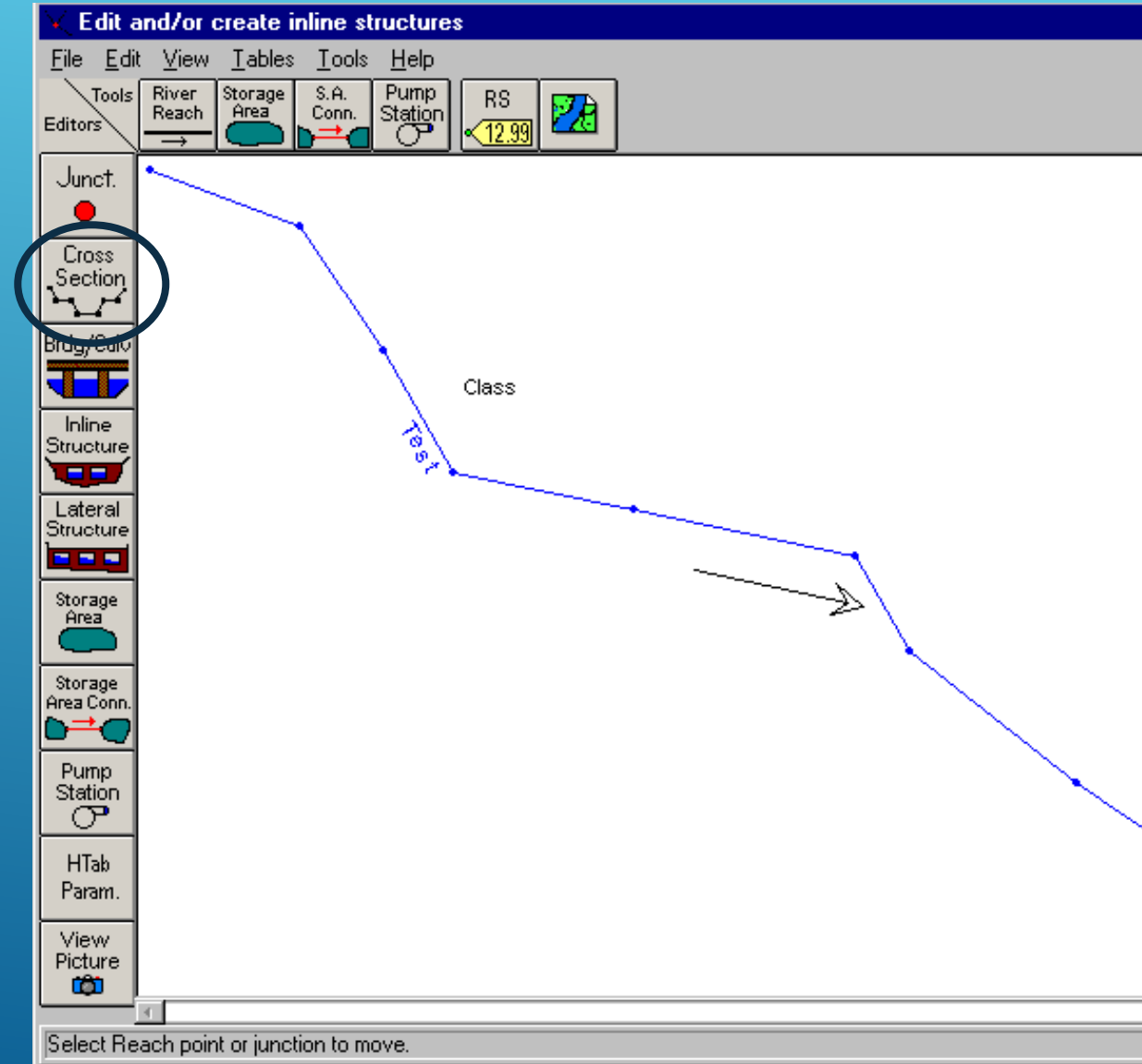

# ADDING CROSS SECTIONS TO REACHES

This brings up the Cross Section Data window from where you choose "Options" and then "Add a new Cross-Section..."

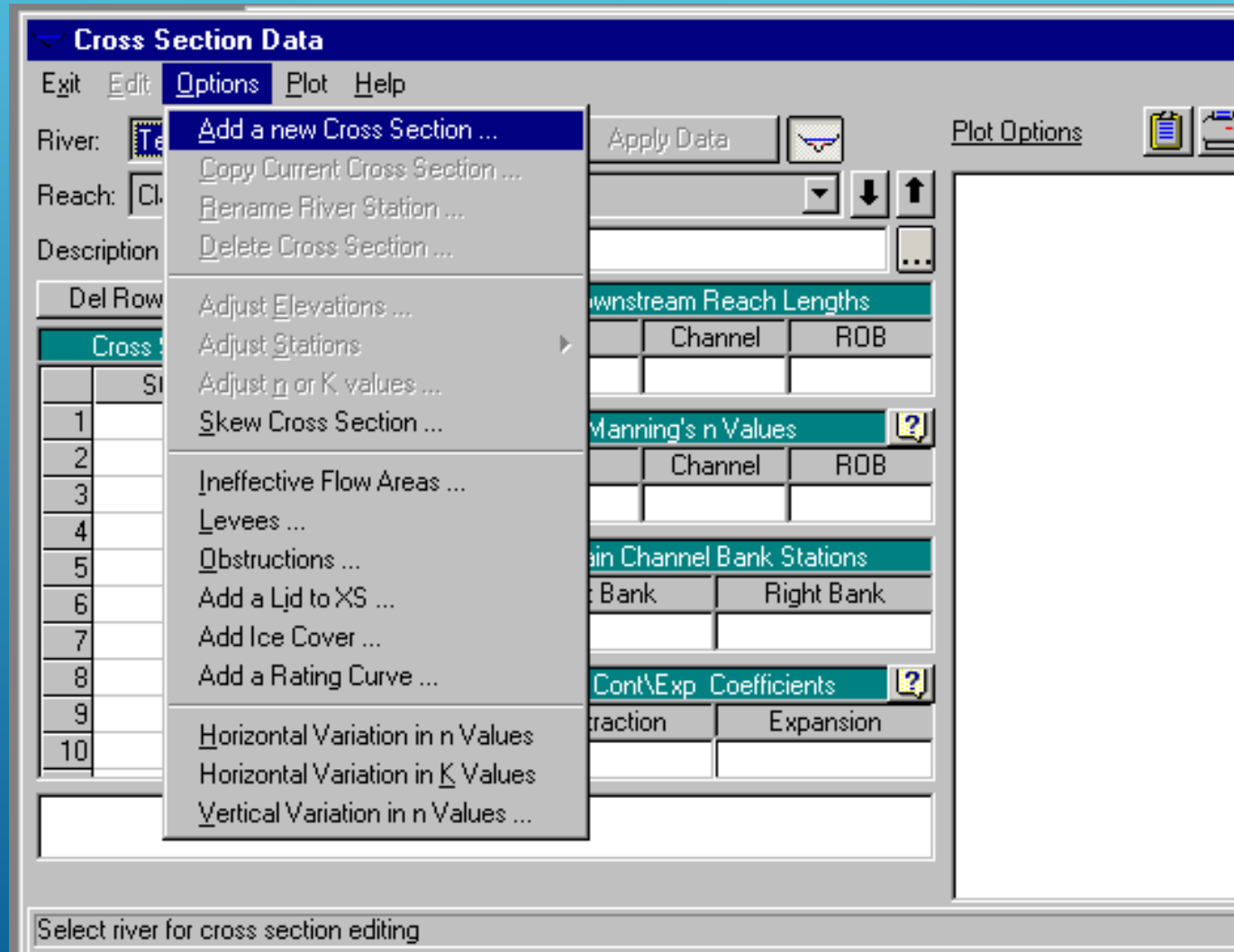

# ADDING CROSS SECTIONS TO REACHES

Enter the cross-section name (it must be a number - and it must be in numerical order - upstream = highest number) and select OK.

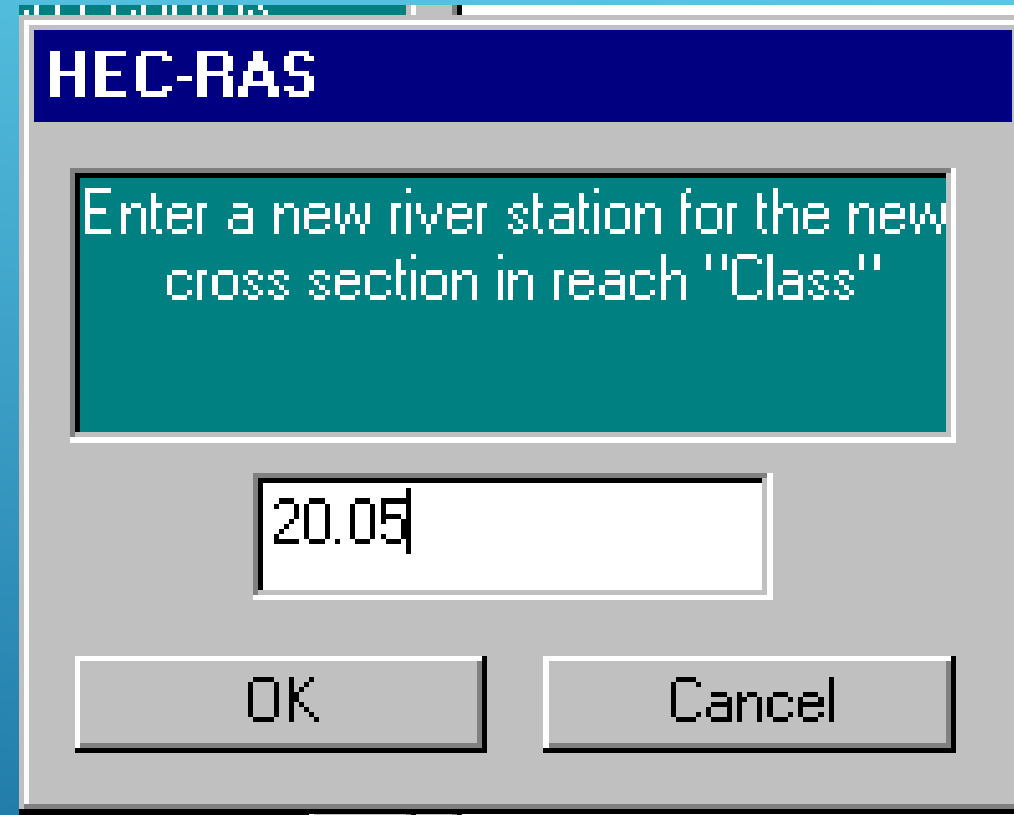
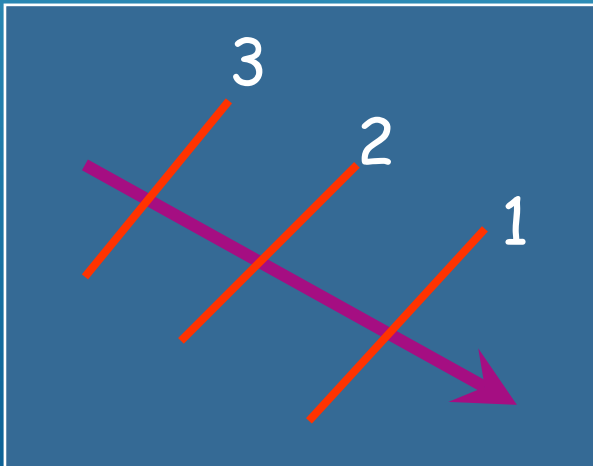

# ENTERING CROSS SECTION DATA

You can enter a lengthy description of the cross-section.

**Cross Section Data - seeley crk COE existing/FIS 9/12/...**

Exit Edit Options Plot Help

River: seeley creek Apply Data

Reach: study reach River Sta.: 1

Description: FIS station a, section 1  
Bradford County: Wells Township  
Downstream Corp. Limit

Cross Sec		Station	Flow	Sub	Channel	Sub
1	0					
2	20					
3	31	1051.9		N/A	N/A	N/A
4	45	1053.4				
5	53	1052.5				
6	63	1054.5				
7	85	1054.4				
8	104	1054.3				
9	109	1051.3	0.047			
10	118	1050.6				

**Main Channel Bank Stations**

Left Bank	Right Bank
109	176

**Cont\Exp Coefficients**

Contraction	Expansion
0.1	0.3

Edit Cross Section Description

# ENTERING CROSS SECTION DATA

This is the main Cross-Section Data window. Here you enter the basic cross-section data such as elevation-station data, reach lengths, 'n' values, bank stations, and contraction and expansion loss coefficients.

**Cross Section Data - seeley creek FIS study run dated 9 dec87**

Exit Edit Options Plot Help

River: seeley creek Apply Data + [Camera Icon]

Reach: study reach River Sta.: 11 [Down Arrow] [Up Arrow]

Description: station K 127+00 [Ellipsis]

Del Row Ins Row

Cross Section X-Y Coordinates			
	Station	Elevation	
1	0	1202.9	
2	28	1199.2	
3	129	1189.4	
4	163	1185.4	
5	197	1180.8	
6	200	1178.8	
7	212	1178.4	
8	219	1178.6	
9	223	1180.1	
10	272	1179.4	

Downstream Reach Lengths		
LOB	Channel	ROB
1300	1300	1249.82

Manning's n Values		
LOB	Channel	ROB
0.075	0.047	0.075

Main Channel Bank Stations	
Left Bank	Right Bank
200	219

Cont\Exp Coefficients	
Contraction	Expansion
0.5	0.7

Edit Station Elevation Data (ft)

Note: Orientation is looking downstream

# ENTERING CROSS SECTION DATA

There are several options available to further refine the cross section data.

**Cross Section Data - seeley creek FIS study run dated 9 dec87**

Exit Edit **Options** Plot Help

River: [sl] Reach: [sl] Description: [ ]

Del Row

Cross	St
1	0
2	28
3	129
4	163
5	197
6	200
7	212
8	219
9	223
10	272

Apply Data [ + ] [ ]

[ 11 ] [ ] [ ] [ ]

**Downstream Reach Lengths**

	Channel	ROB
	1300	1249.82

**Manning's n Values**

	Channel	ROB
	0.047	0.075

**Main Channel Bank Stations**

	Left Bank	Right Bank
		219

**Cont/Exp Coefficients**

	Contraction	Expansion
		0.7

Edit Station Elevation Data (ft)

# ENTERING CROSS SECTION DATA

A quick visual check of the data is available through the "Plot Cross Section (in separate window)" option.

**Cross Section Data - St Croix EWP revised**

Exit Edit Options **Plot** Help

River: StCroix

Reach: StCroix

Description: Sta. 11+30

Cross Section X-Y Coordinates			
	Station	Elevation	
1	320	105	
2	400	100	
3	468.03	96.96	
4	555	96	
5	573.7	96	
6	589	88.35	
7	600	88.35	
8	611	88.35	
9	628.3	97	
10	800.91	97	

Downstream Reach Lengths		
LOB	Channel	ROB
10	10	10

Manning's n Values		
LOB	Channel	ROB
0.07	0.03	0.07

Main Channel Bank Stations	
Left Bank	Right Bank
573.7	628.3

Cont/Exp Coefficients	
Contraction	Expansion
0.1	0.3

# ENTERING CROSS SECTION DATA

The plot displays 'n' values, bank stations, a legend, and elevation station coordinates as the mouse is moved around.

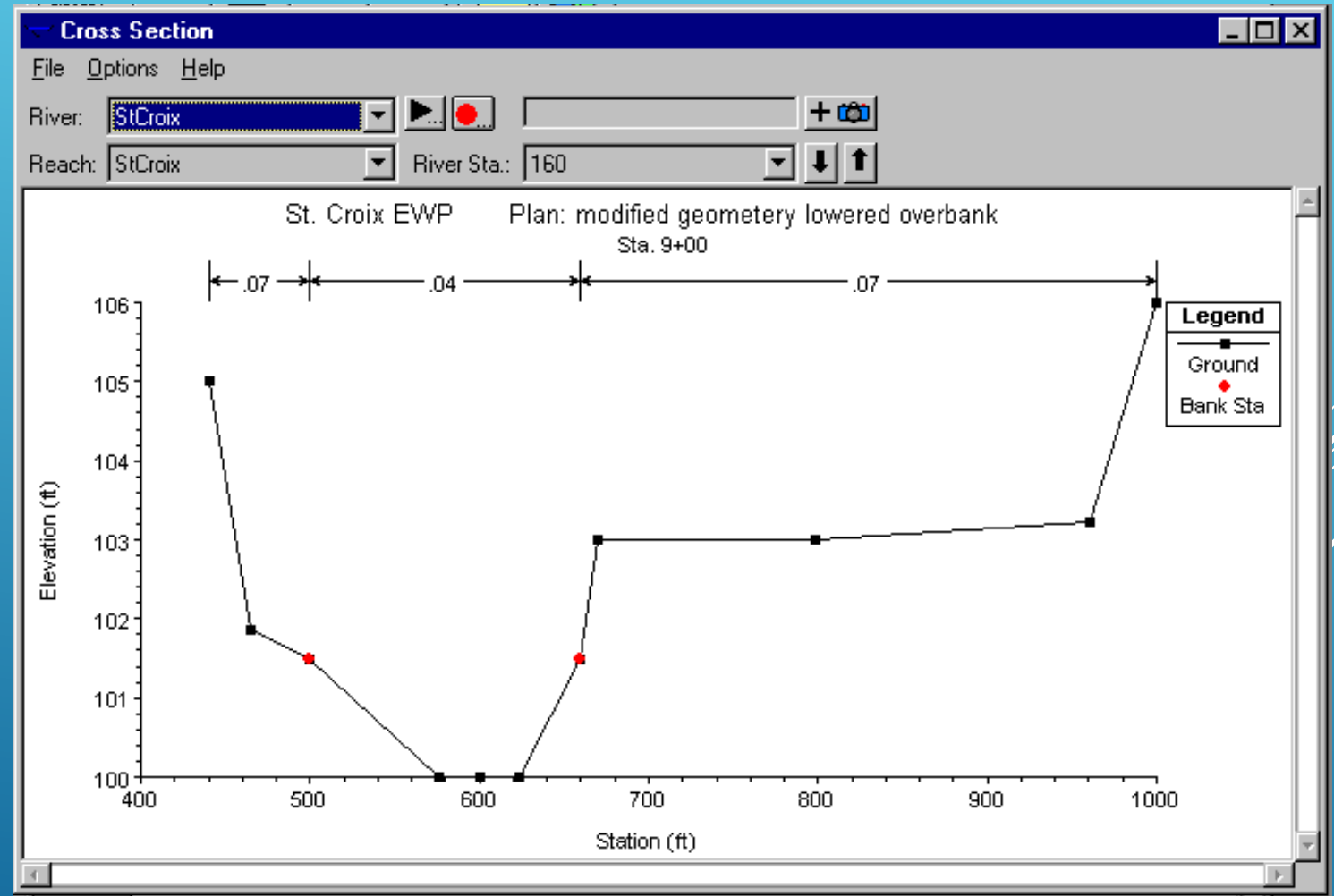



Note: Orientation is looking downstream

# ENTERING CROSS SECTION DATA

Or plot it directly in the editor

**Cross Section Data - St Croix EWP revised**

Exit Edit Options Plot Help

River: **StCroix** Apply Data  + 

Reach: **StCroix** River Sta.: **90** ↓ ↑

Description: **Sta. 11+30** ...



Del Row	Ins Row	
	Cross Section X-Y Coordinates	
	Station	Elevation
1	320	105
2	400	100
3	468.03	96.96
4	555	96
5	573.7	96
6	589	88.35
7	600	88.35
8	611	88.35
9	628.3	97
10	800.91	97

Downstream Reach Lengths		
LOB	Channel	ROB
10	10	10

Manning's n Values		
LOB	Channel	ROB
0.07	0.03	0.07

Main Channel Bank Stations	
Left Bank	Right Bank
573.7	628.3

Cont\Exp Coefficients	
Contraction	Expansion
0.1	0.3

Plot Options    Keep Prev XS Plots Clear Prev

St. Croix BMP Plan: modified geometry lowered outbank 1/3/03  
River = St Croix Reach = St Croix RS = 90 Sta. 11+30

**Legend**

- Ground
- Bank Sta

Select river for cross section editing

# ENTERING CROSS SECTION DATA

Can show other sections on the plot

**Cross Section Data - St Croix EWP revised**

Exit Edit Options Plot Help

River: StCroix Apply Data Plot Options  Keep Prev XS Plots Clear Prev

Reach: StCroix River Sta.: 140

Description: Sta. 10+20

Del Row	Ins Row	Cross Section X-Y Coordinates	
		Station	Elevation
		380	105
1		440	100
2		452.19	97.46
3		503.3	97.25
4		578	97.25
5		583	94.6
6		600	94.6
7		617	94.6
8		623	97.5
9		794.92	97.5
10			

Downstream Reach Lengths		
LOB	Channel	ROB
20	20	20

Manning's n Values		
LOB	Channel	ROB
0.07	0.03	0.07

Main Channel Bank Stations	
Left Bank	Right Bank
578	623

Cont\Exp Coefficients	
Contraction	Expansion
0.1	0.3

St. Croix EWP Plan: modified geometry lowered overbank 1/30/03

River = StCroix Reach = StCroix RS = 140 Sta. 10+20

Elevation (ft)

Station (ft)

Enter to move to next downstream river station location

- ▶ X-sections should extend across the entire floodplain and be perpendicular to anticipated flow lines (approximately perpendicular to ground contour lines).
- ▶ X-sections should accurately represent stream and floodplain geometry. Put in where changes occur in discharge, slope, shape, roughness, and bridges.
- ▶ Enter X-Section elevation-station data from left to right as seen when looking downstream.
- ▶ Cross-Sections should start far enough D.S. to “zero out” any errors in boundary conditions assumptions (for sub-critical profile). The opposite is true for super-critical flow.

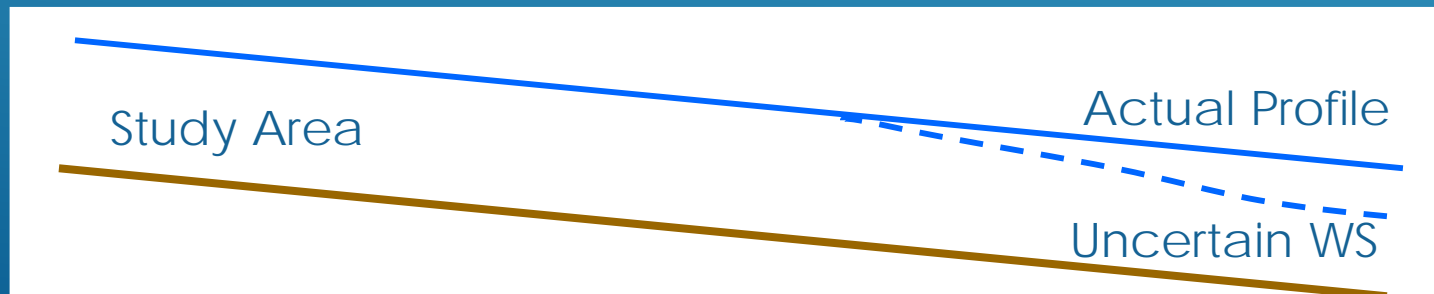

- ▶ Location of X-sections within a reach varies with the intensity of the study and the conditions of the reach
- ▶ The choice of friction loss equations will also affect X-section spacing and predicted flood elevations
- ▶ Higher number X-section river stations are assumed to be upstream of lower number river stations
- ▶ The left side of the X-section, looking downstream, is assumed to have the lower X values and progress right as the X values increase, (can not narrow the section)

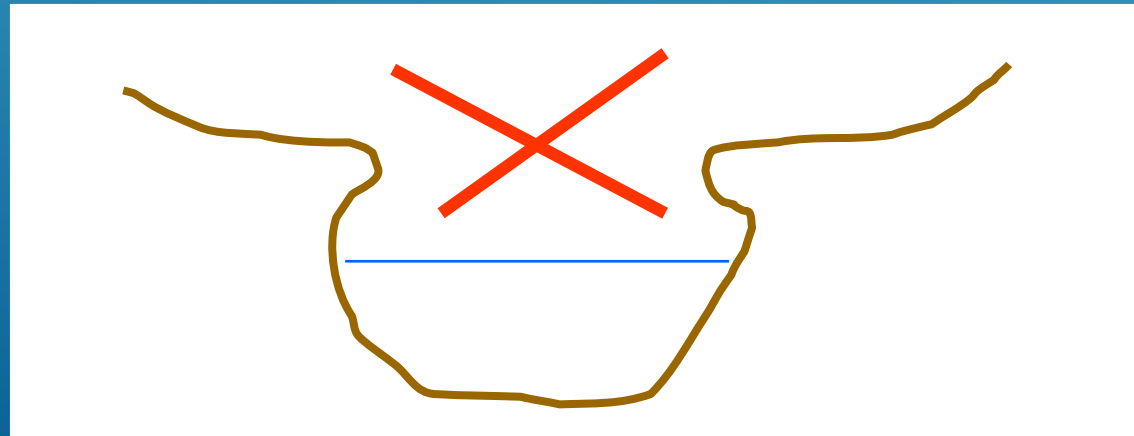

# NOTES ON CROSS-SECTION DATA (CONT.)

- ▶ The left and right channel bank must be given at a station located in the X-section elevation-station data set.
- ▶ Boundaries are fixed, can not reflect changes during a storm (scour deposition).
- ▶ X-section **endpoints** that are below the computed water surface profile will be extended vertically to contain the routed flows with area/wetted perimeter reflecting this boundary condition.

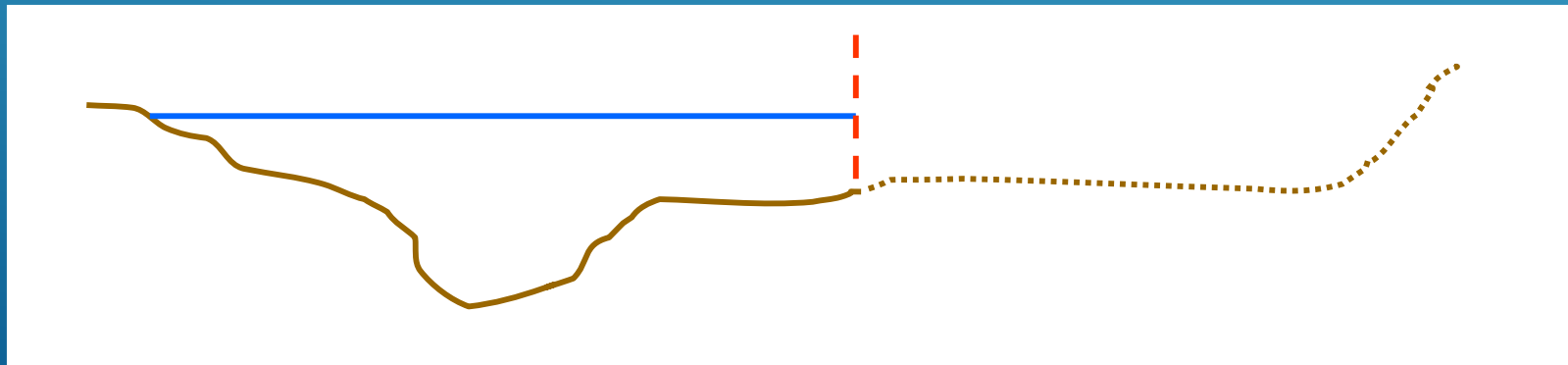

# NOTES ON CROSS-SECTION DATA (CONT.)

- ▶ Consider what is being modeled. The program can only reflect what is being entered.

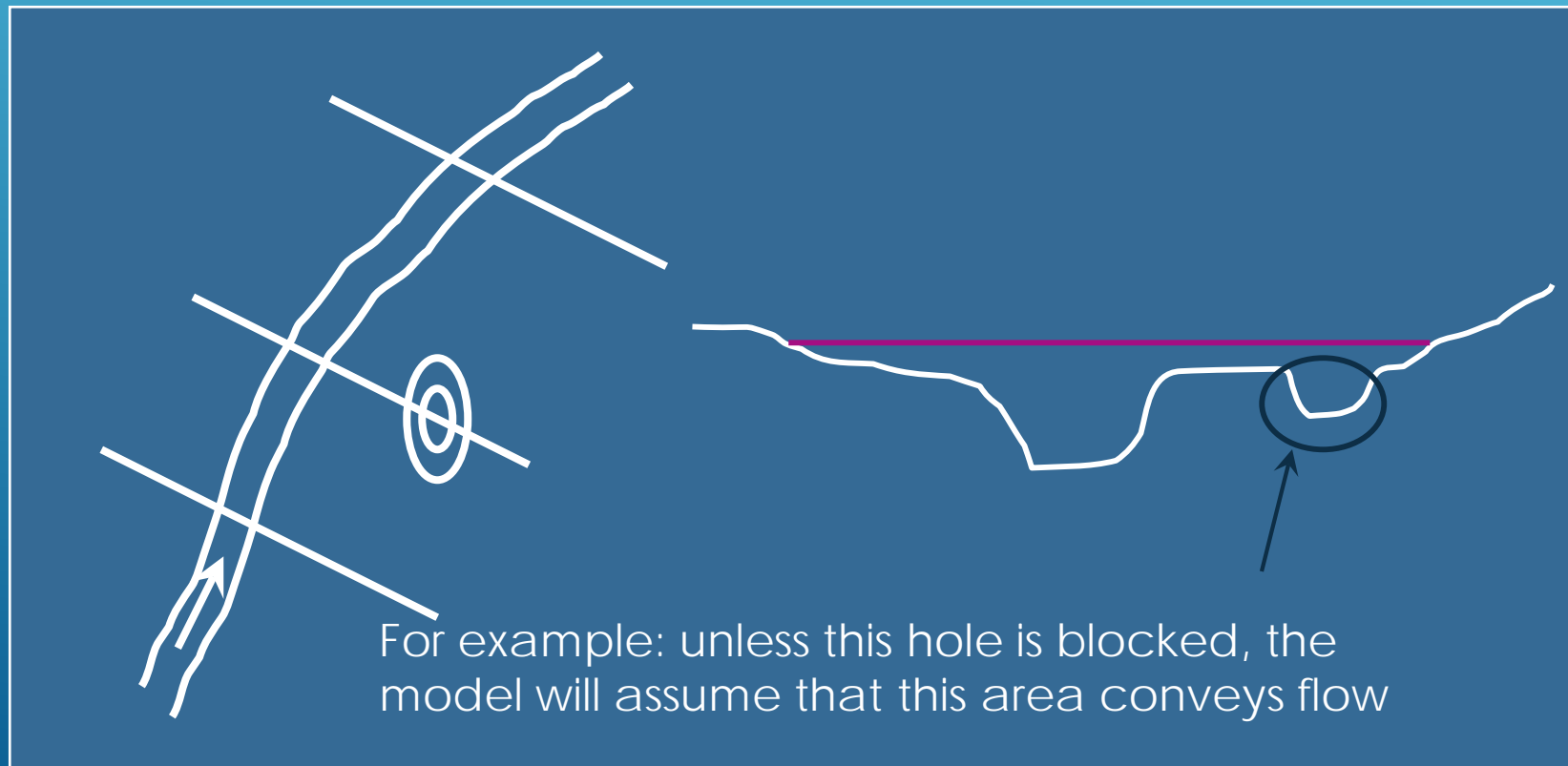

# NOTES ON CROSS-SECTION DATA (CONT.)

- HEC-RAS has an option to create interpolated cross sections.

By reach

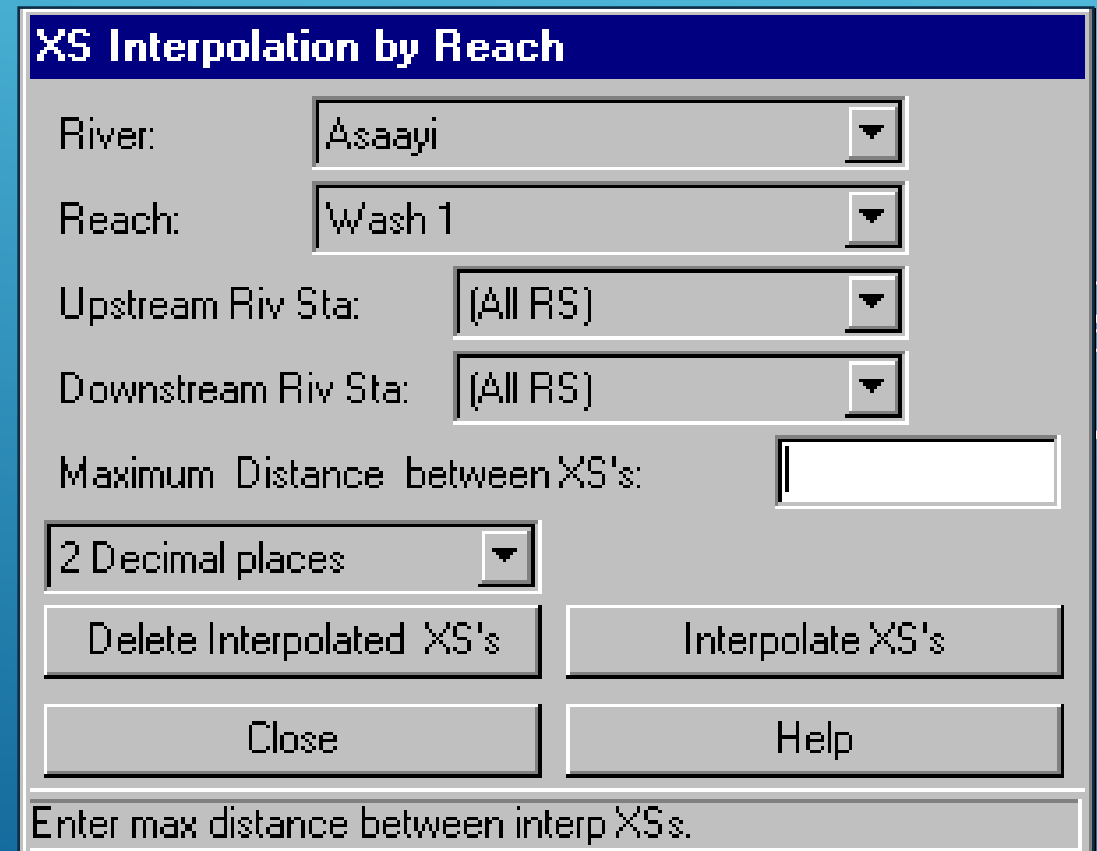
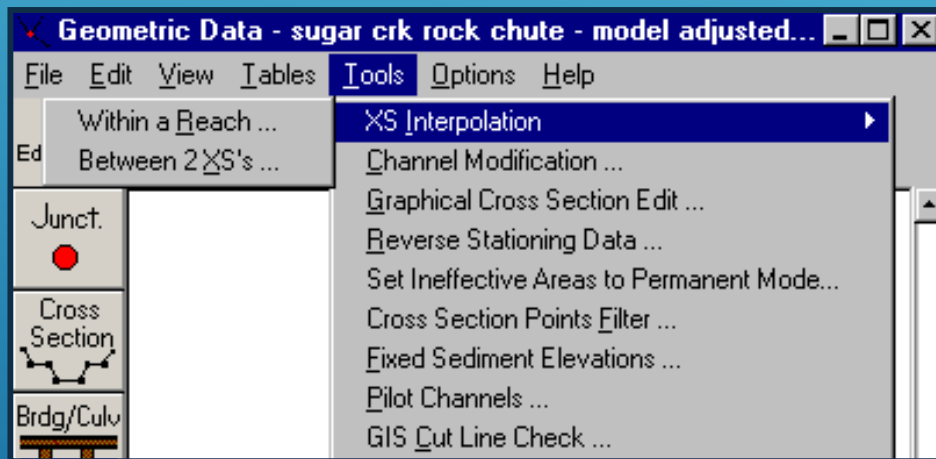

# NOTES ON CROSS-SECTION DATA (CONT.)

- HEC-RAS has an option to create interpolated cross sections.

or between two sections

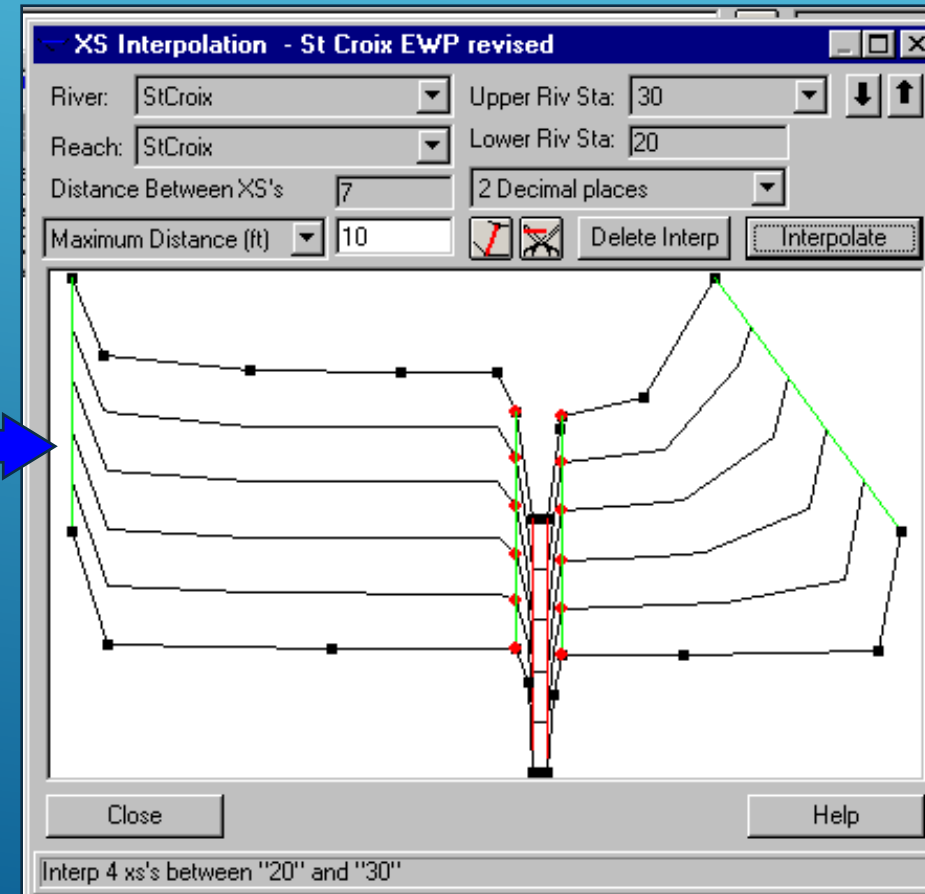
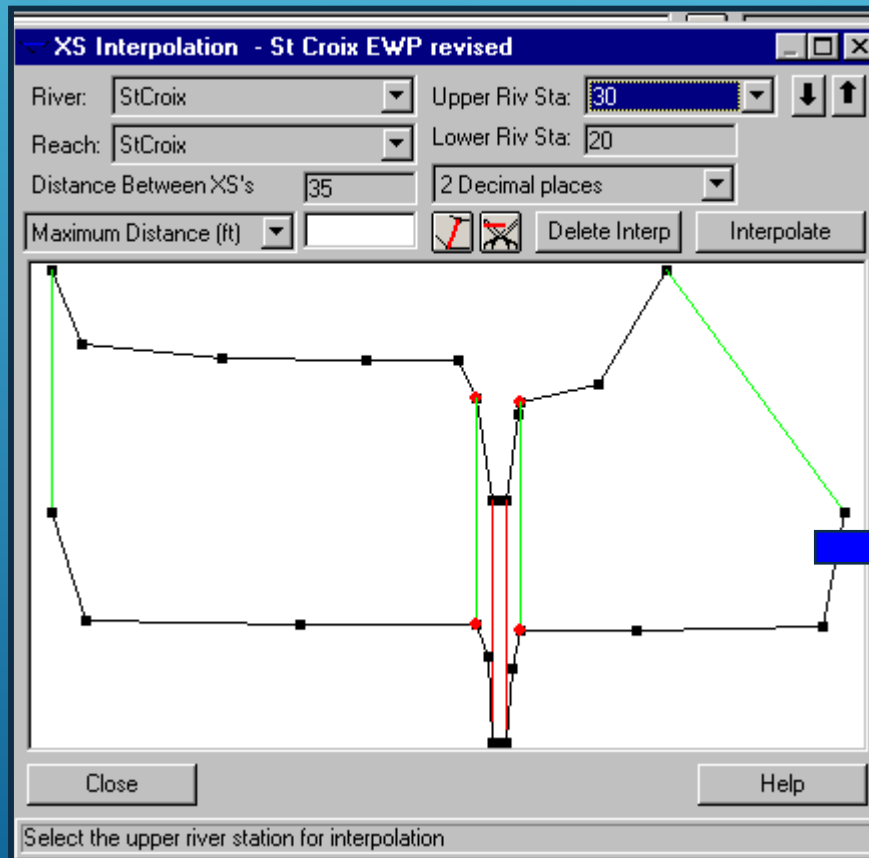

- ▶ Measured distances between X-Sections, reported as distance to D.S. X-Sections.

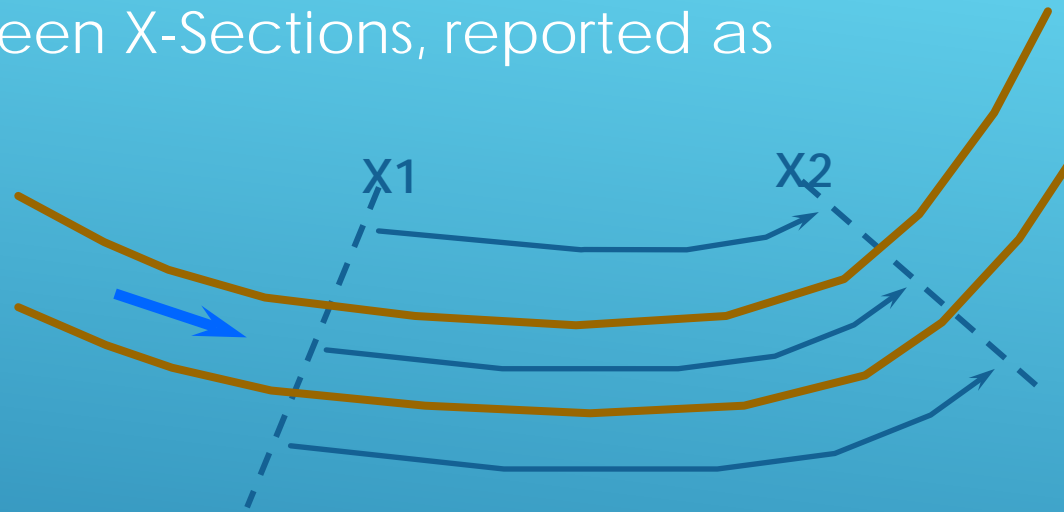

- ▶ Left overbank, right overbank, and channel
- ▶ Can be very different for channels with large meander or in a bend of a river.
- ▶ A discharge weighted total reach length is determined based on the discharges in the main channel and left and right overbank segments.

$$L = \frac{L_{lob} \bar{Q}_{lob} + L_{ch} \bar{Q}_{ch} + L_{rob} \bar{Q}_{rob}}{\bar{Q}_{lob} + \bar{Q}_{ch} + \bar{Q}_{rob}}$$

# EXPANSION & CONTRACTION COEFFICIENTS

	<b>Contraction</b>	<b>Expansion</b>
<b>No Transition</b>	<b>0.0</b>	<b>0.0</b>
<b>Gradual Transition</b>	<b>0.1</b>	<b>0.3</b>
<b>Typical Bridge Transition</b>	<b>0.3</b>	<b>0.5</b>
<b>Abrupt Transition</b>	<b>0.6</b>	<b>0.8</b>

- ▶ Typical values for gradual transitions in supercritical flow are 0.05 for contraction and 0.10 for expansions.
- ▶ Constructed prismatic channels should have expansion and contraction coefficients of 0.0

# INEFFECTIVE FLOW AREAS

- ▶ Ineffective flow areas are used to model portions of the cross-section in which water will pond, but the velocity of that water in the downstream direction is equal to zero.
- ▶ This water is included in the storage and wetted cross section parameters, but not in the active flow area.
- ▶ No additional wetted parameter is added to the active flow area (unlike encroachments).
- ▶ Once ineffective flow area is overtopped, then that specific area is no longer considered ineffective.
- ▶ Commonly used near road crossings.

# INEFFECTIVE FLOW AREAS

- ▶ Two types of Ineffective Flow Areas :
  - ▶ 1. **Normal** where you supply left and right stations with elevations which block flow to the left of the left station and to the right of the right station
  - ▶ 2. **Blocked** where you can have multiple (up to 10) blocked flow areas within the X-section

Once water surface goes above the established elevations, then that specific area is no longer considered ineffective.

*Normal  
Ineffective  
Flows*

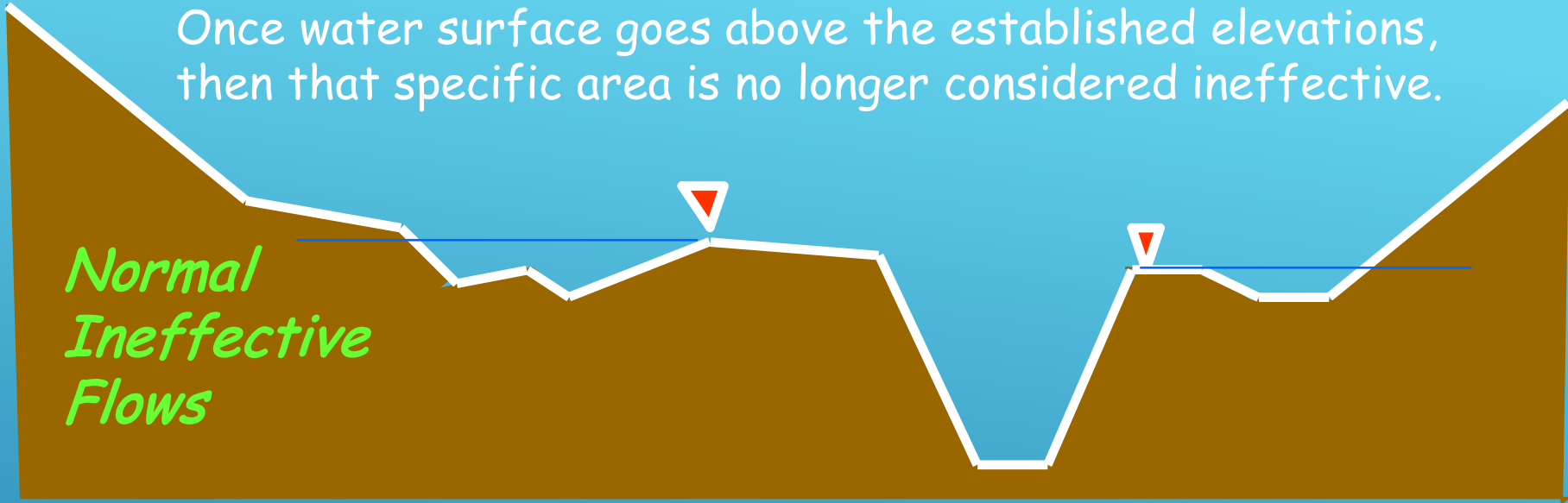

Once water surface goes above the established elevations of the block, then that specific area is no longer considered ineffective.

*Blocked  
Ineffective  
Flows*

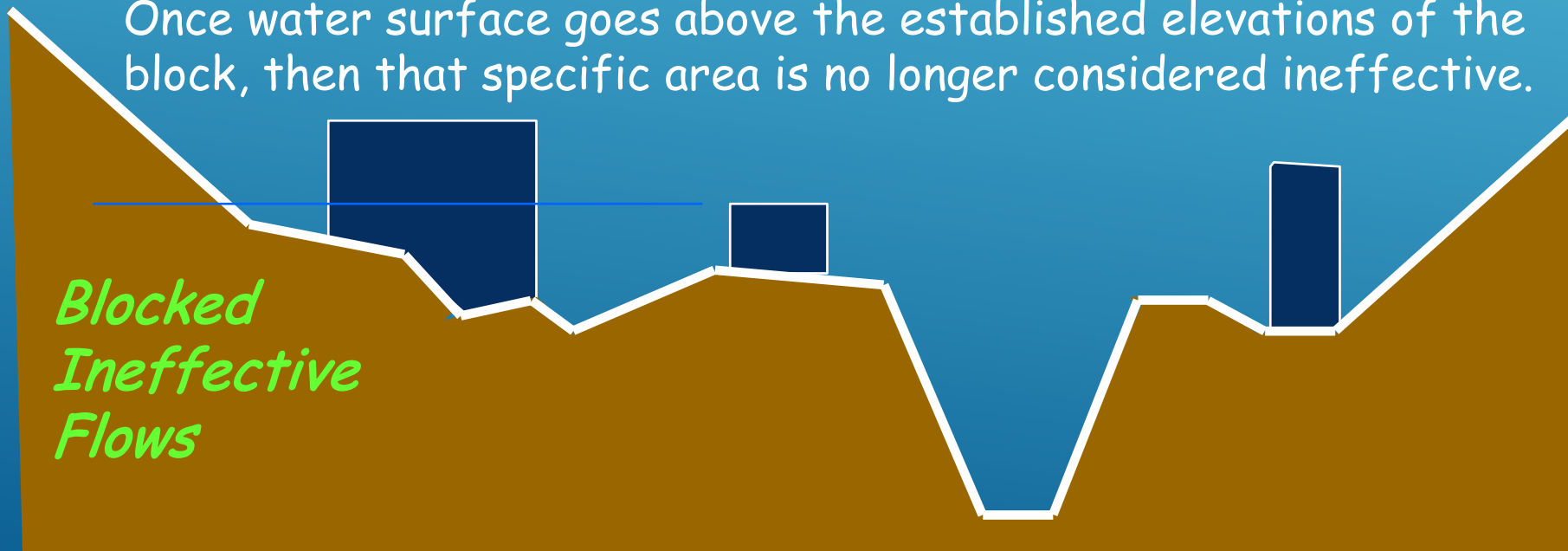

# INEFFECTIVE FLOW AREAS

Option is from x-section

Del Row	Cross	St
1	100	
2	131.3	
3	400.7	
4	571	
5	582	
6	590	
7	600	
8	610	
9	618	
10	633	

Downstream Reach Lengths	
Channel	ROB
63	63

Manning's n Values	
Channel	ROB
0.04	0.07

Main Channel Bank Stations	
Bank	Right Bank
	633

Cont\Exp Coefficients	
Contraction	Expansion
	0.3

Select river for cross section editing

which brings up this window:

Select Ineffective Mode

Normal     Multiple Blocks

Left                      Right

Station                                           

Elevation                                           

Permanent     Permanent

OK    Cancel    Defaults    Clear

# INEFFECTIVE FLOW AREAS

The plotted x-section looks like this:

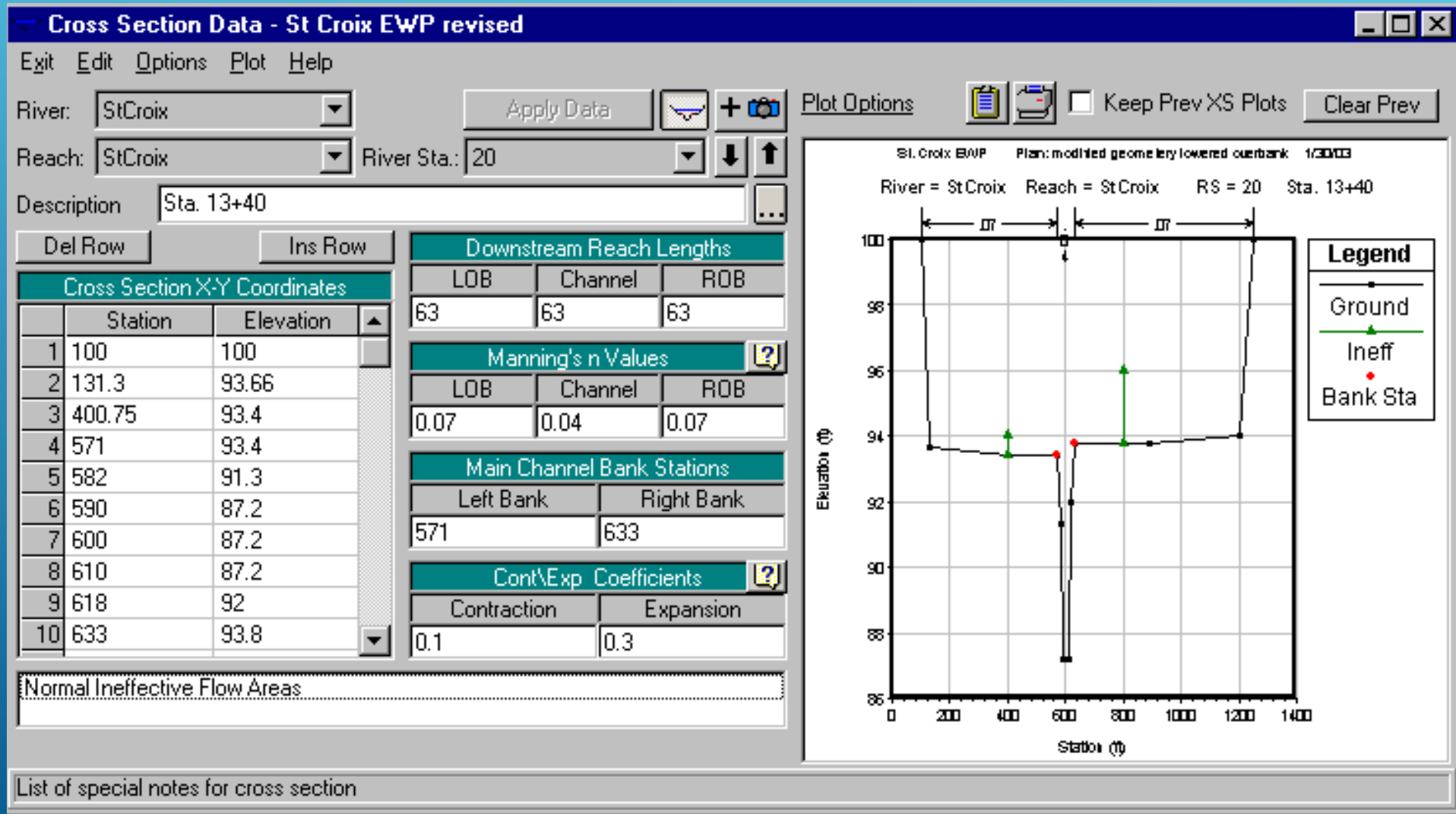

# INEFFECTIVE FLOW AREAS

*Think of them as  
dead storage  
zones*

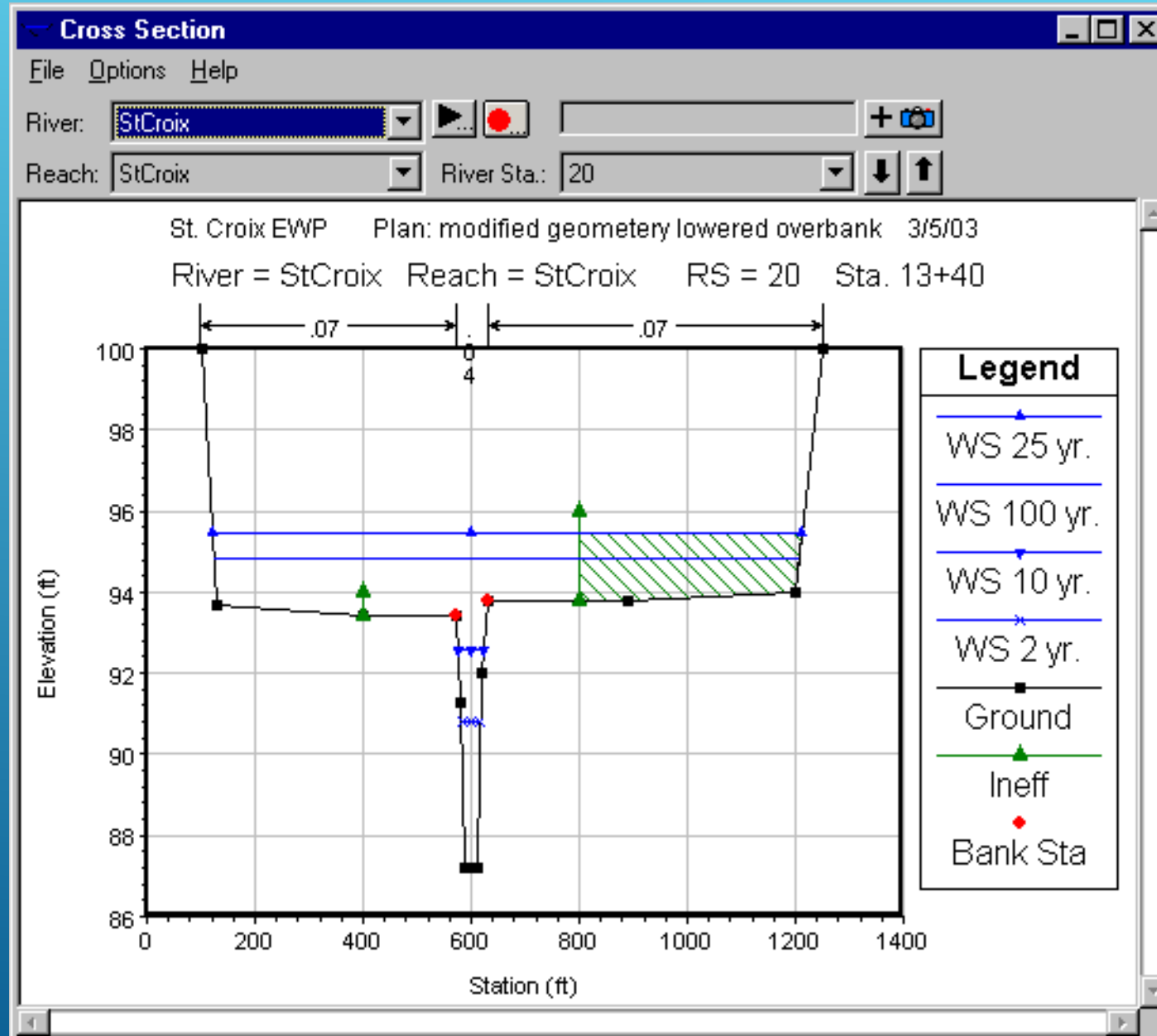

- ▶ Used to define areas that will be permanently blocked out.
- ▶ Decreases flow area and increases wetted perimeter when the water comes in contact with it.
- ▶ Two types of blocked obstructions are available - Normal and Multiple. They are very similar to the Ineffective Flow areas, except that the blocked areas are never available as water flow areas.
- ▶ Water can get to the off-sides of these obstructions.

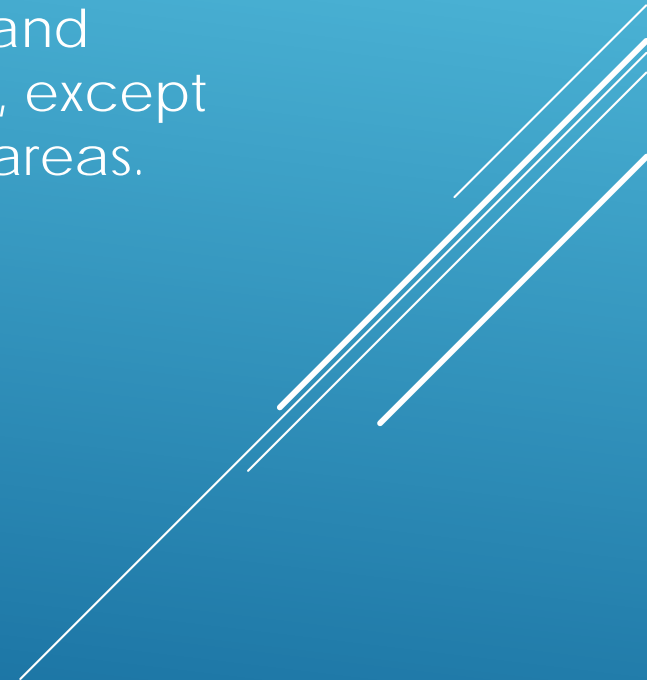

the blocked areas are never available as water flow areas.

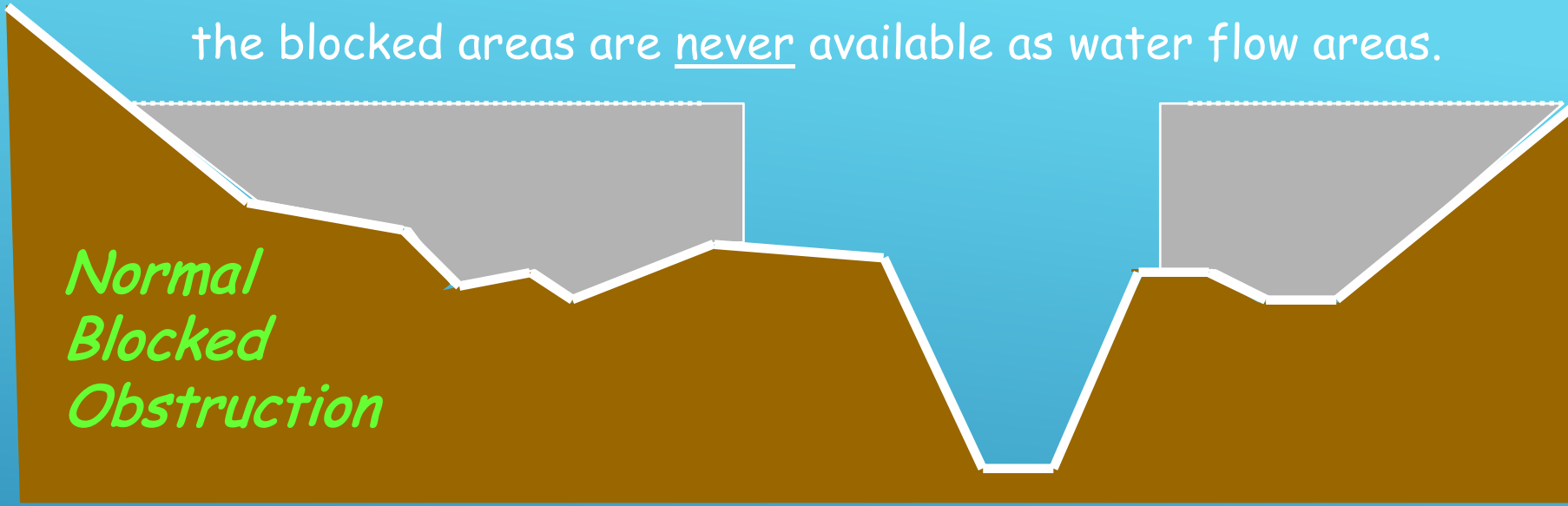

the blocked areas are never available as water flow areas.

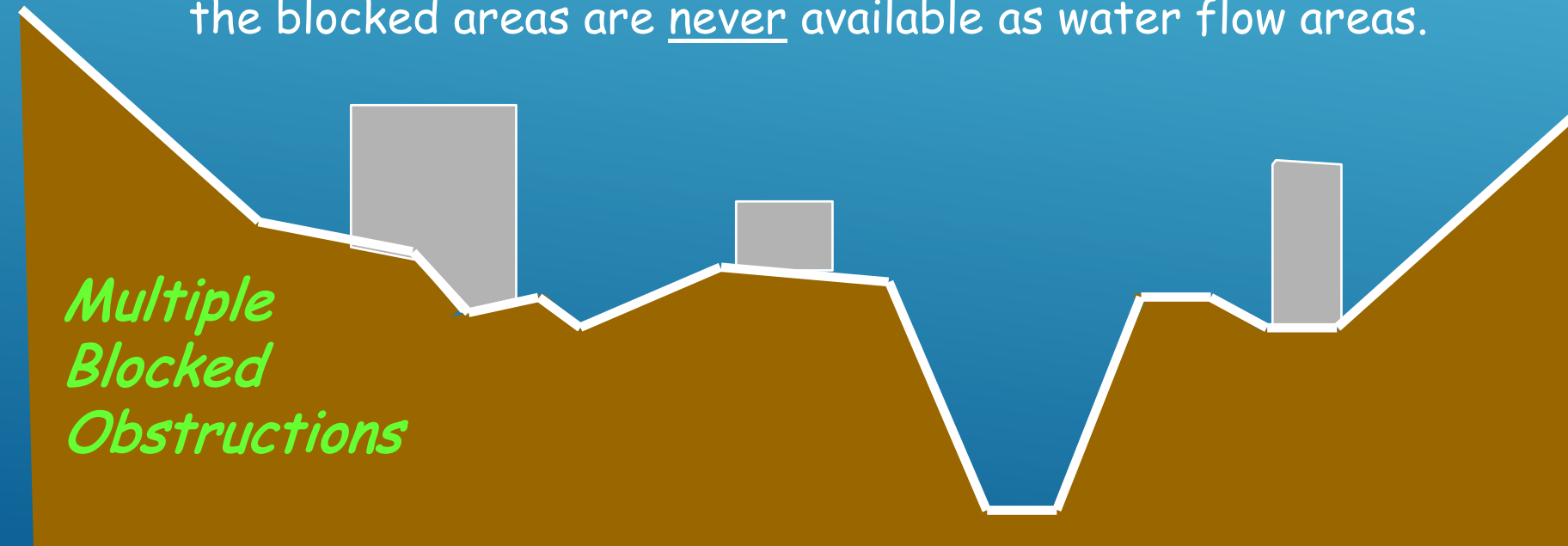

# BLOCKED OBSTRUCTIONS

Option is from x-section window...

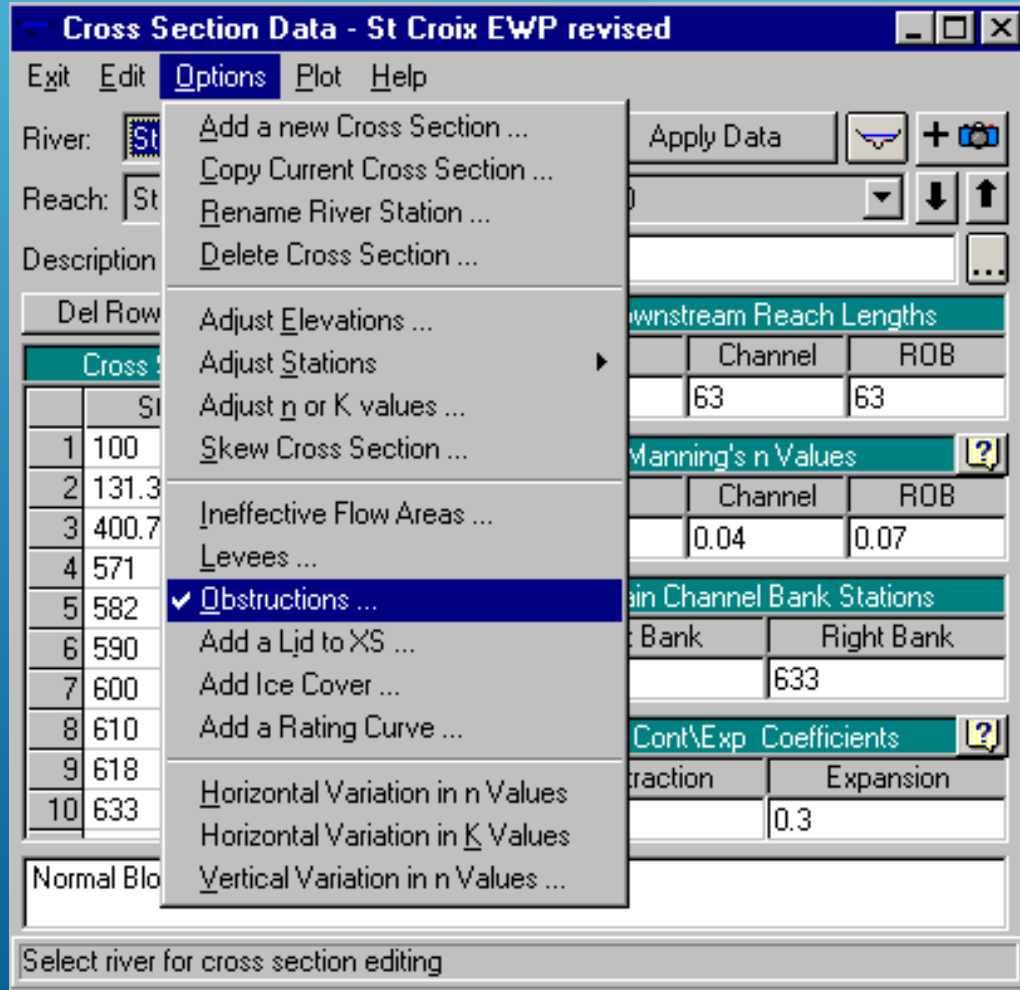

which brings up this window:

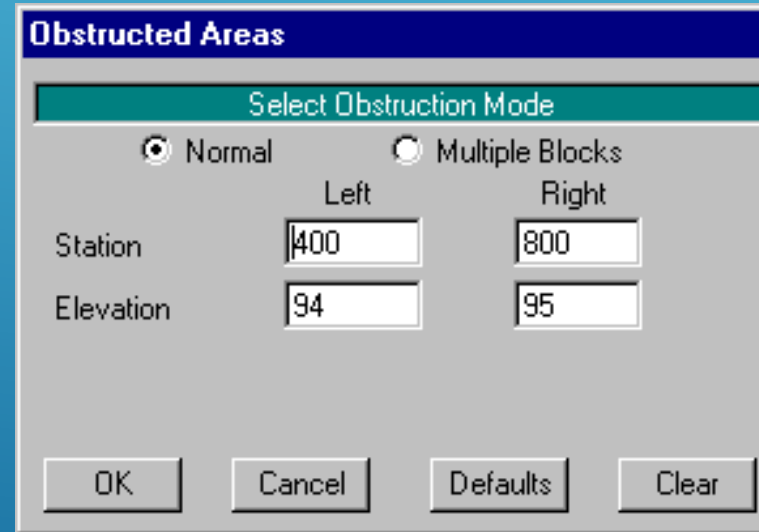

# BLOCKED OBSTRUCTIONS

The plotted x-section looks like this:

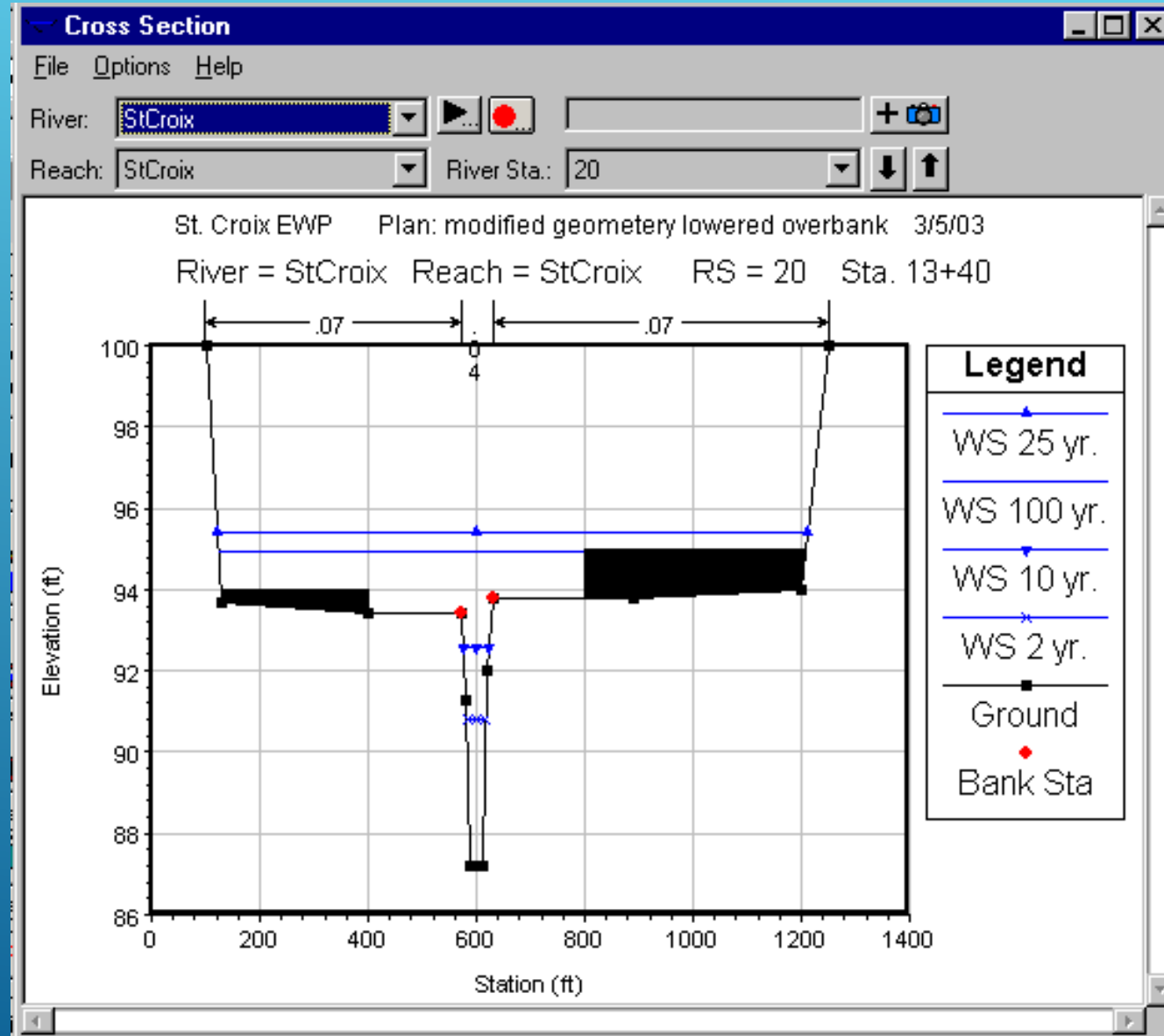

# LEVEES

- ▶ No water can get outside of a levee until it is overtopped.
- ▶ Simulated by a vertical wall.
- ▶ Additional wetted perimeter is included when water comes in contact with the levee wall.

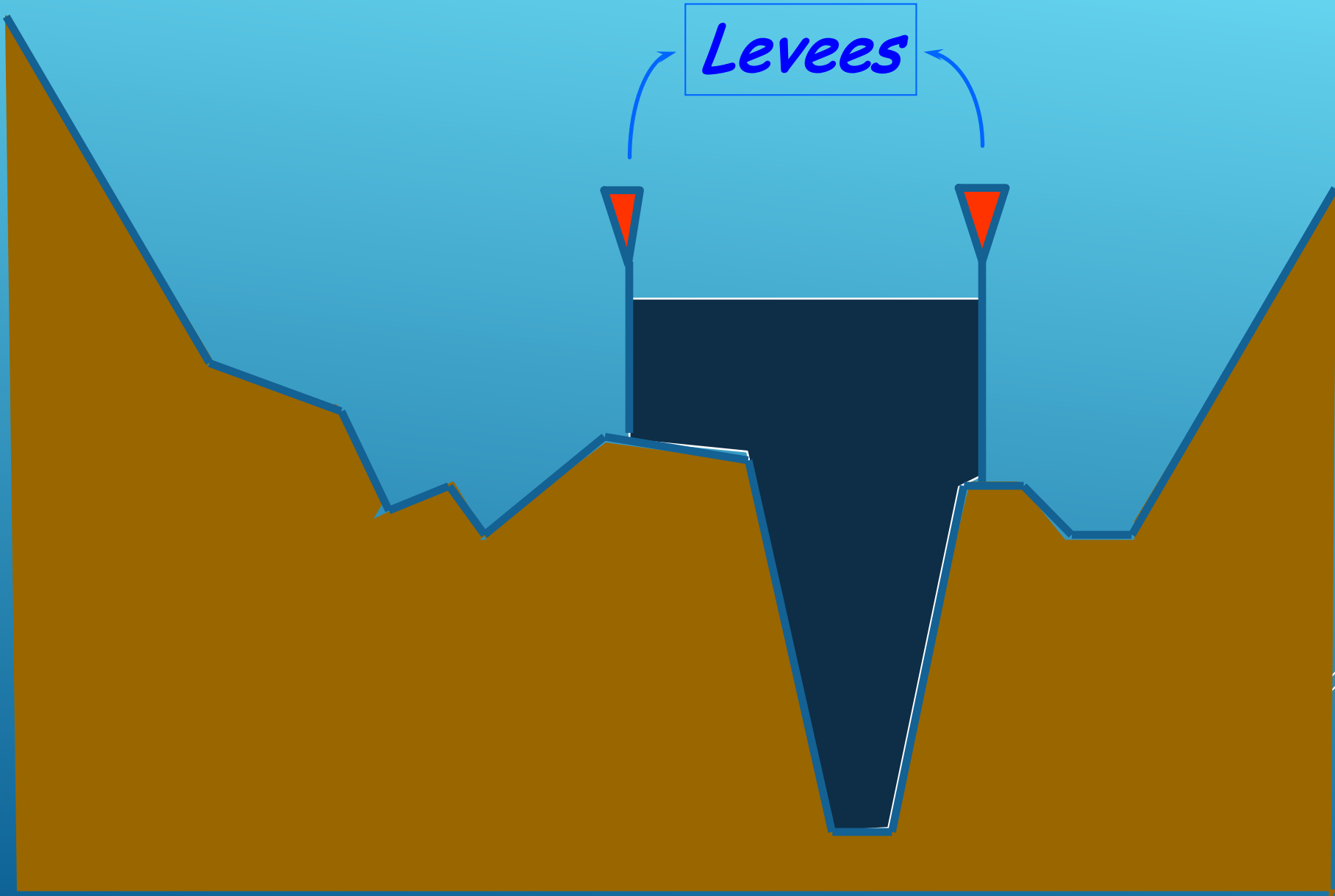

# LEVEES

Option is from x-section window...

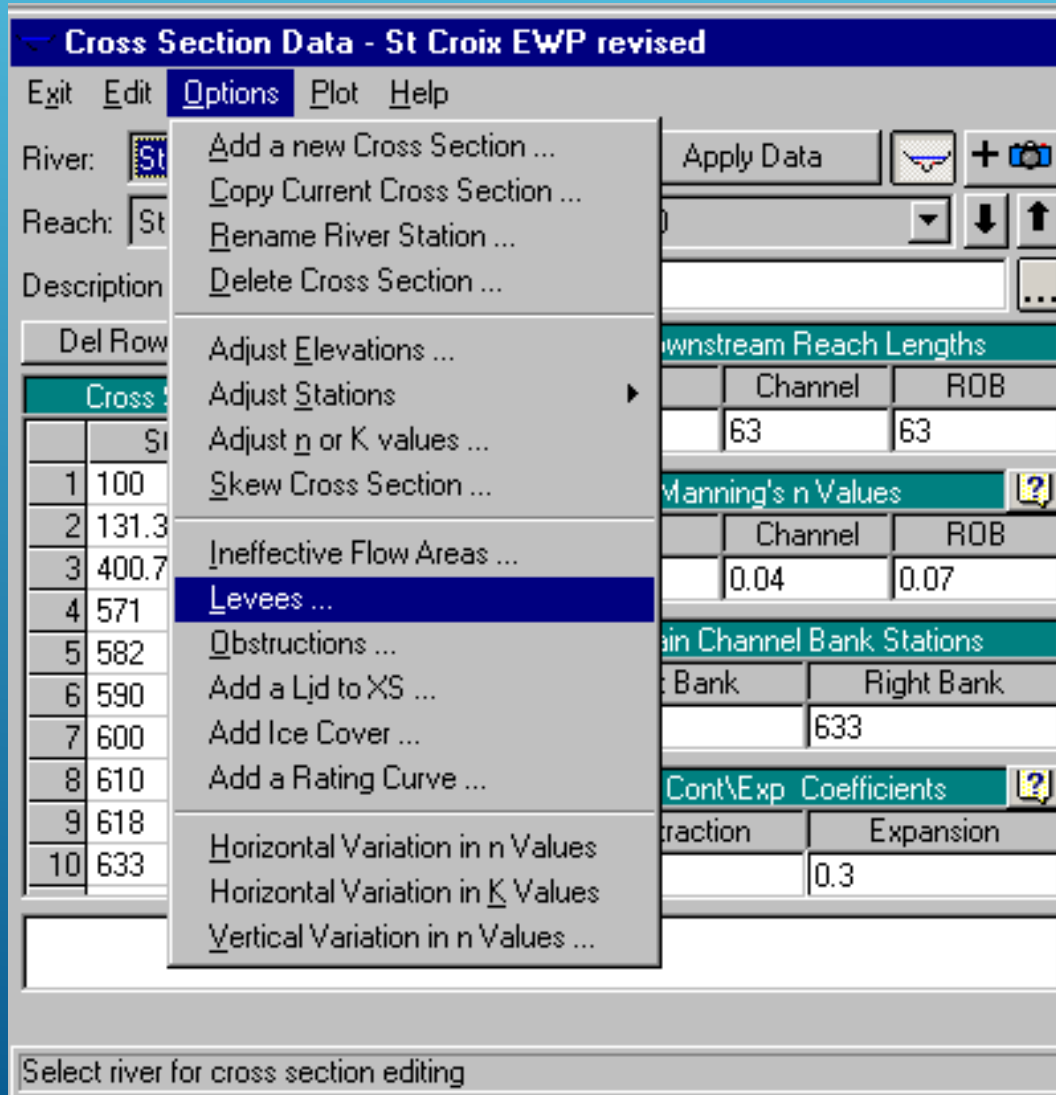

which brings up this window:

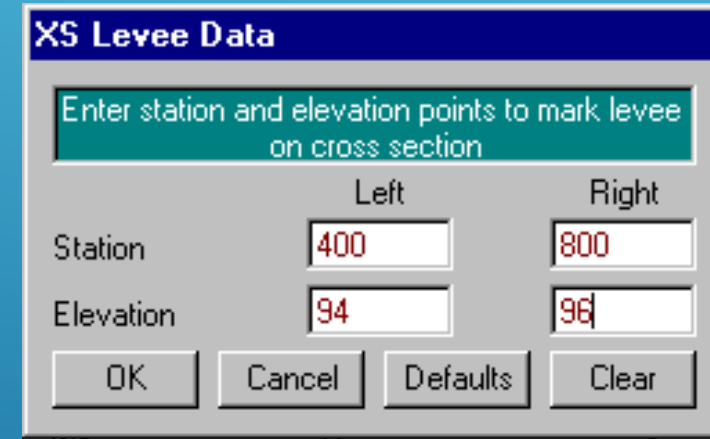

The plotted x-section looks like this:

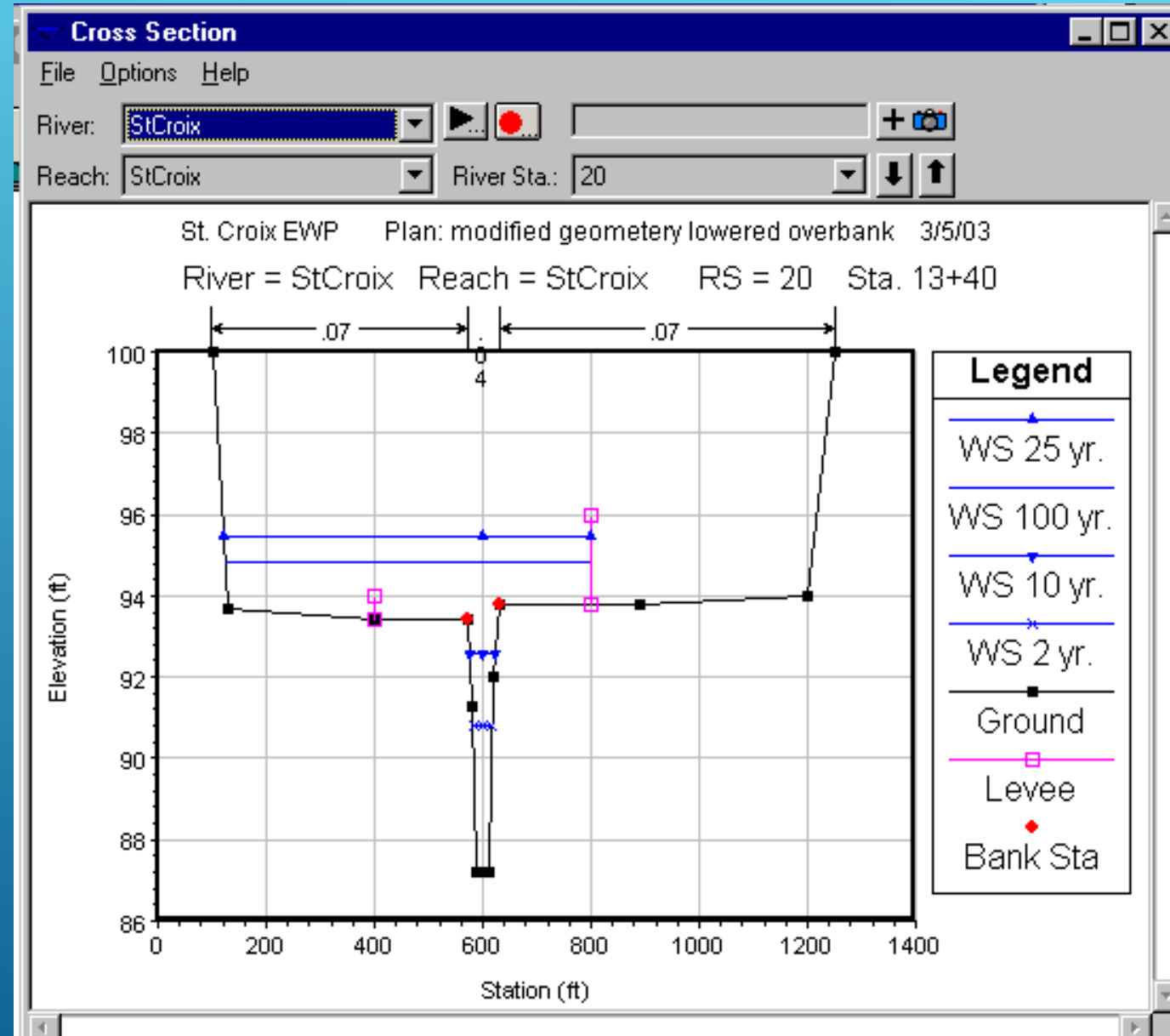

# LEVEES VS. INEFFECTIVE FLOW AREAS

- ▶ Are conceptually similar but very different hydraulically
- ▶ Ineffective flow areas is used where water is present to the left/right of the ineffective station but the velocity is zero. Volume included in storage and wetted perimeter calculations but not in conveyance. (think: ponded area)
- ▶ A levee acts as a vertical wall. No water occupied the space to the left/right of the levee unless the levee elevation is exceeded. The distance that the levee is in contact with the water is included in the wetted perimeter calculations. (think: wall)



# ENTERING CROSS SECTION DATA

After entering geometry data, it is wise to save it. Recommend doing this often as you enter data.

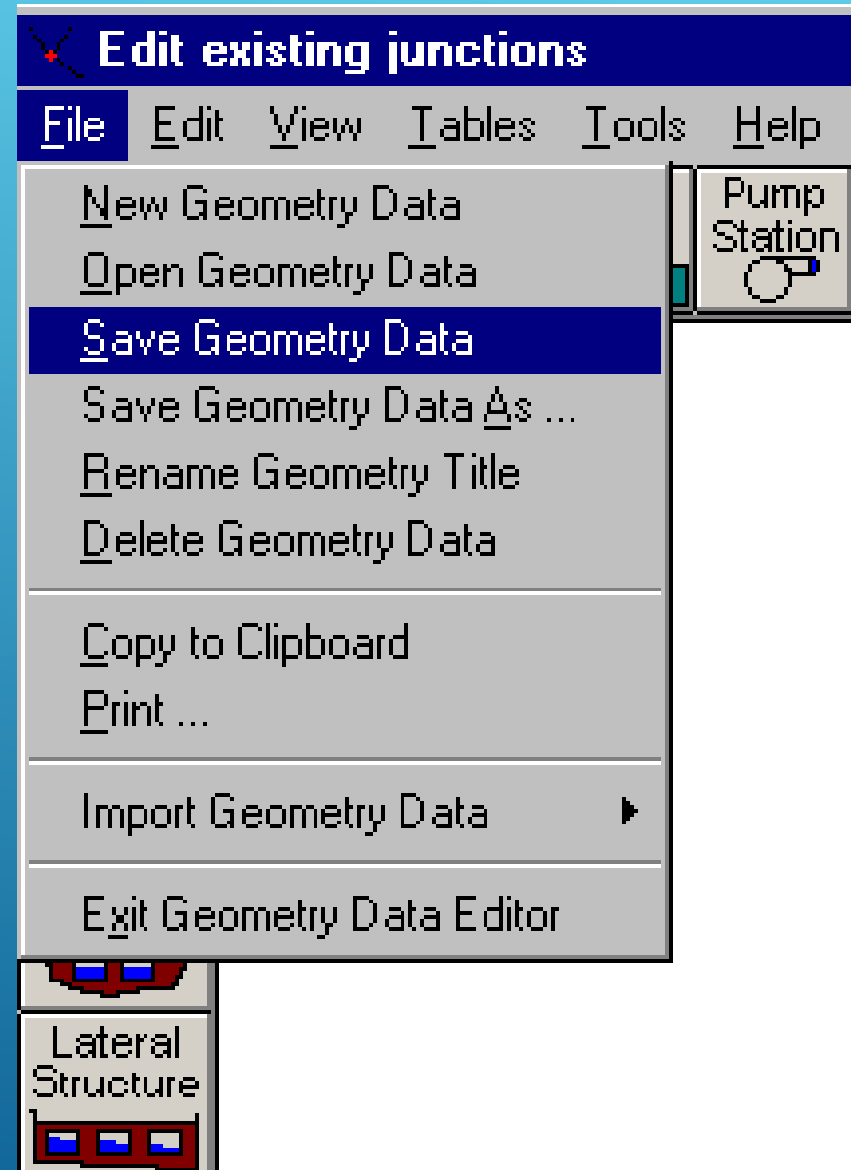

# FLOW DATA

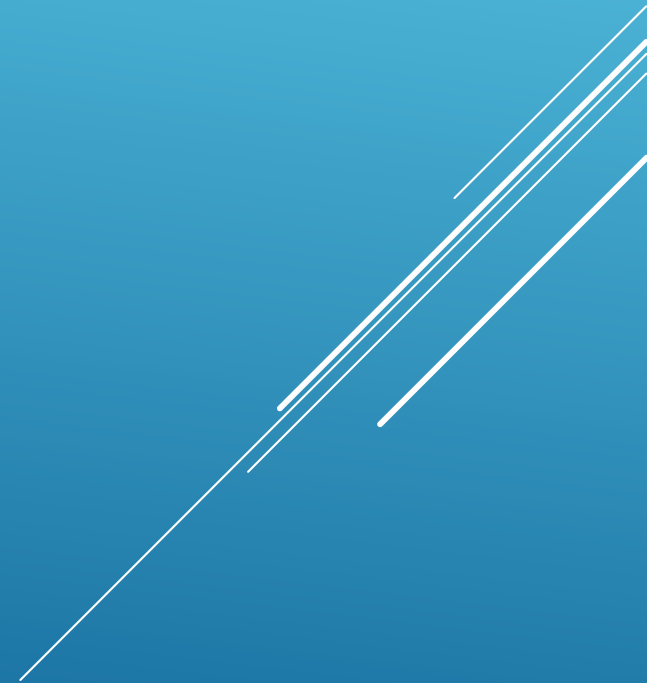

# ENTER FLOW DATA

Enter the Steady Flow Data Editor from the main menu

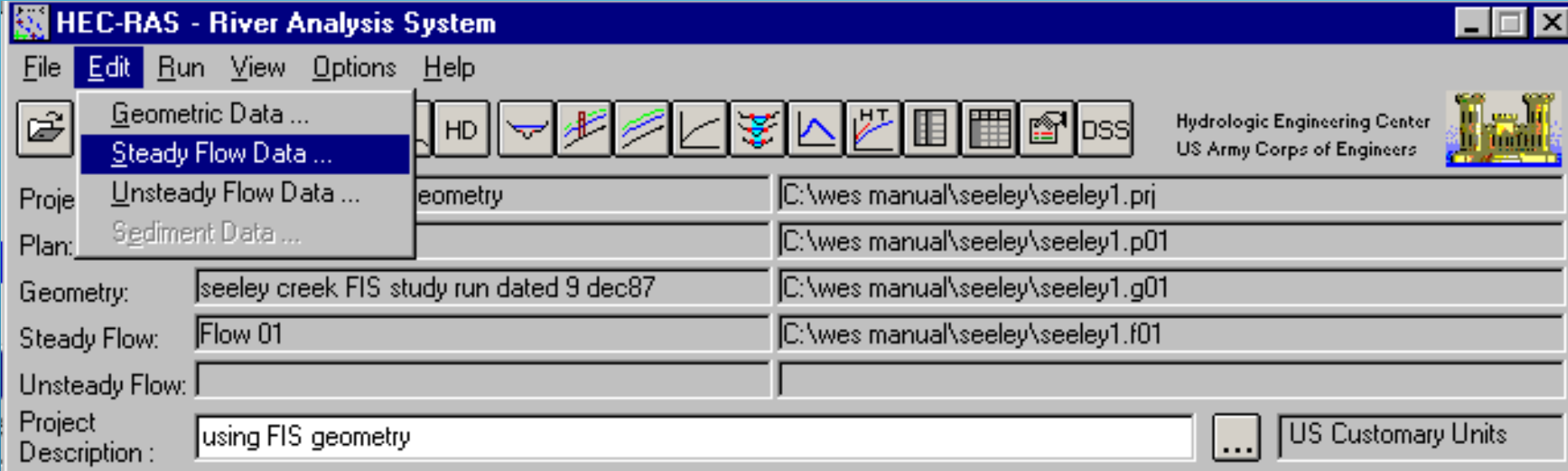

Or, you can select the Steady Flow Data button:

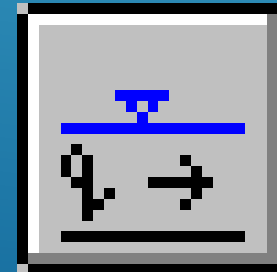

# ENTER FLOW DATA

This brings up the Steady Flow Data Window:

**Steady Flow Data - trial 1 flows**

File Options Help

Enter/Edit Number of Profiles (2000 max):

**Locations of Flow Data Changes**

River:

Reach:   River Sta.:

Flow Change Location				Profile Names and Flow Rates	
	River	Reach	RS	PF 1	
1	Mill Creek	project area	100		

Edit Steady flow data for the profiles (cfs)

# ENTER FLOW DATA

You can have up to 100 profiles. Note it brought up 3 boxes when 3 profiles were specified.

**Steady Flow Data** [ - ] [ □ ] [ X ]

File Options Help

Enter/Edit Number of Profiles (100 max):

Locations of Flow Data Changes

River:

Reach:   River Sta.:

Flow Change Location				Profile Names and Flow Rates		
	River	Reach	RS	PF 1	PF 2	PF 3
1	Test	Main	20.05			

[Edit Steady flow data for the profiles (cfs)]

# ENTER FLOW DATA

Enter the discharges for each profile in appropriate box.

**Steady Flow Data** File Options Help

Enter/Edit Number of Profiles (100 max):

Locations of Flow Data Changes

River:    
 Reach:   River Sta.:

Flow Change Location				Profile Names and Flow Rates		
	River	Reach	RS	PF 1	PF 2	PF 3
1	Test	Main	20.05	100	250	400

Edit Steady flow data for the profiles (cfs)

# ENTER FLOW DATA

Can add flow changes along reach.

- Select River Station
- Click “Add a Flow Change Location”

**Steady Flow Data - trial 1 flows**

File Options Help

Enter/Edit Number of Profiles (2000 max):

**Locations of Flow Data Changes**

River:    
 Reach:   River Sta.:

Flow Change Location		
River	Reach	RS
1	Mill Creek	project area
2	Mill Creek	project area

Profile Names and Flow Rates	
Profile Name	Flow Rate
PF 3	

Select river station for adding a new flow change location.

# ENTER FLOW DATA

Then you simply specify the flows at that location.

**Steady Flow Data**

File Options Help

Enter/Edit Number of Profiles (100 max):

**Locations of Flow Data Changes**

River:    
 Reach:   River Sta.:

Flow Change Location				Profile Names and Flow Rates		
	River	Reach	RS	PF 1	PF 2	PF 3
1	Test	Main	20.05	100	250	400
2	Test	Main	18	120	265	410

Edit Steady flow data for the profiles (cfs)

# ENTER FLOW DATA

Set the boundary conditions by selecting “Reach Boundary Conditions”

**Steady Flow Data**

File Options Help

Enter/Edit Number of Profiles (100 max):

Locations of Flow Data Changes

River:

Reach:  River Sta.:

Flow Change Location				Profile Names and Flow Rates		
	River	Reach	RS	PF 1	PF 2	PF 3
1	Test	Main	20.05	100	250	400
2	Test	Main	18	120	265	410

Edit Steady flow data for the profiles (cfs)

# ENTER FLOW DATA

This brings up Steady Flow Boundary Conditions window. You can set the boundary for all profiles at once, or ...

**Steady Flow Boundary Conditions**

Set boundary for all profiles
  Set boundary for one profile at a time

Available External Boundary Condition Types

Selected Boundary Condition Locations and Types

River	Reach	Profile	Upstream	Downstream
Mill Creek	project area	all		

Enter to accept data changes.

# ENTER FLOW DATA

You can set boundary conditions for each profile separately. There are 4 different methods for specifying the starting water surface: known elevation, critical depth, normal depth, or rating curve.

**Steady Flow Boundary Conditions**

Set boundary for all profiles
  Set boundary for one profile at a time

Available External Boundary Condition Types

Selected Boundary Condition Locations and Types

River	Reach	Profile	Upstream	Downstream
Mill Creek	project area	PF 1		
Mill Creek	project area	PF 2		
Mill Creek	project area	PF 3		

Editor is in a mode that boundary conditions are entered per profile.

# ENTER FLOW DATA

After selecting either the upstream or downstream data box and then selecting method for providing starting conditions, a window appears for entering your data.

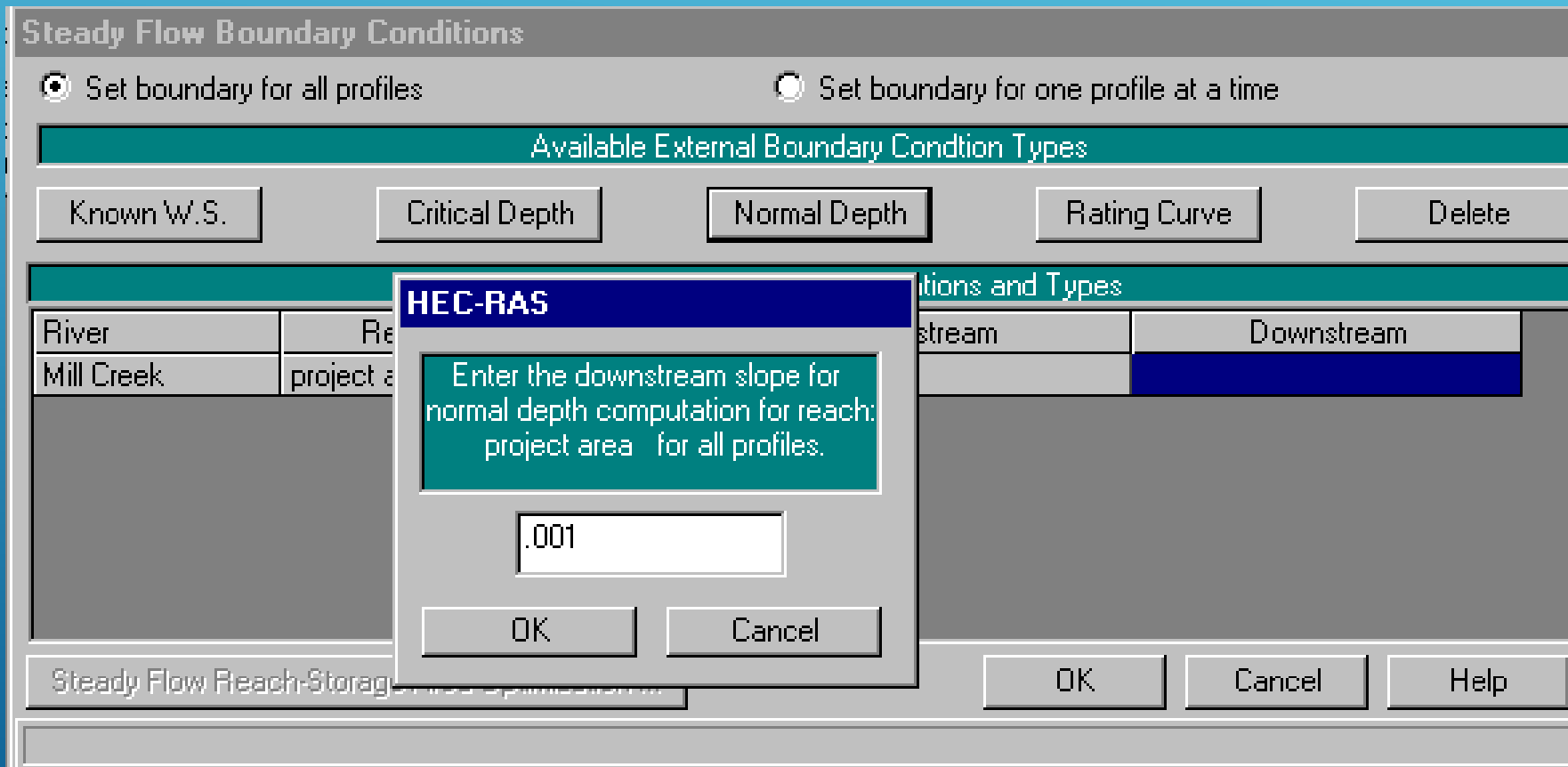

at downstream end for sub-critical, upstream end for super-critical, or at

# ENTER FLOW DATA

There are several options available in the "Options" window of the Steady Flow Data window such as changing profile names, applying a ratio to all flows, etc.

The screenshot shows the HEC-RAS interface. The 'Options' menu is open, highlighting 'Edit Profile Names ...'. A dialog box titled 'HEC-RAS Edit Profile Names. (16 Characters Max)' is displayed in the foreground, containing a table with the following data:

	Profile #	Profile Name
1	1	100 yr FIS
2	2	1.1 yr
3	3	1.25 yr
4	4	2 yr
5	5	2.33 yr
6	6	mean flow

Below the dialog box, the 'Flow Rates' table is visible:

Flow Rates		
	2.33 yr	mean flow
09	1556	8.5
09	1556	8.5

The status bar at the bottom of the window reads: 'Edit Steady flow data for the profiles (cfs)'.

# ENTER FLOW DATA

After entering your flow data, it is suggested you save it to a file.

**Steady Flow Data - TR-20 Flow Data, All Events**

File   Options   Help

- New Flow Data
- Open Flow Data ...
- Save Flow Data**
- Save Flow Data AS ...
- Rename Flow Title ...
- Delete Flow Data ...

---

- Set Location for DSS Connections ...
- DSS Import ...

---

- Exit Flow Data Editor

Station	Flow Data	Year
3 Dry Brook	Steep	10
4 Pocasset River	Johnston Upper	56686
5 Pocasset River	Johnston Upper	44000

# SAVE PROJECT

After entering and saving the geometry and flow data, it is suggested that you save your project from the main HEC-RAS File Menu.

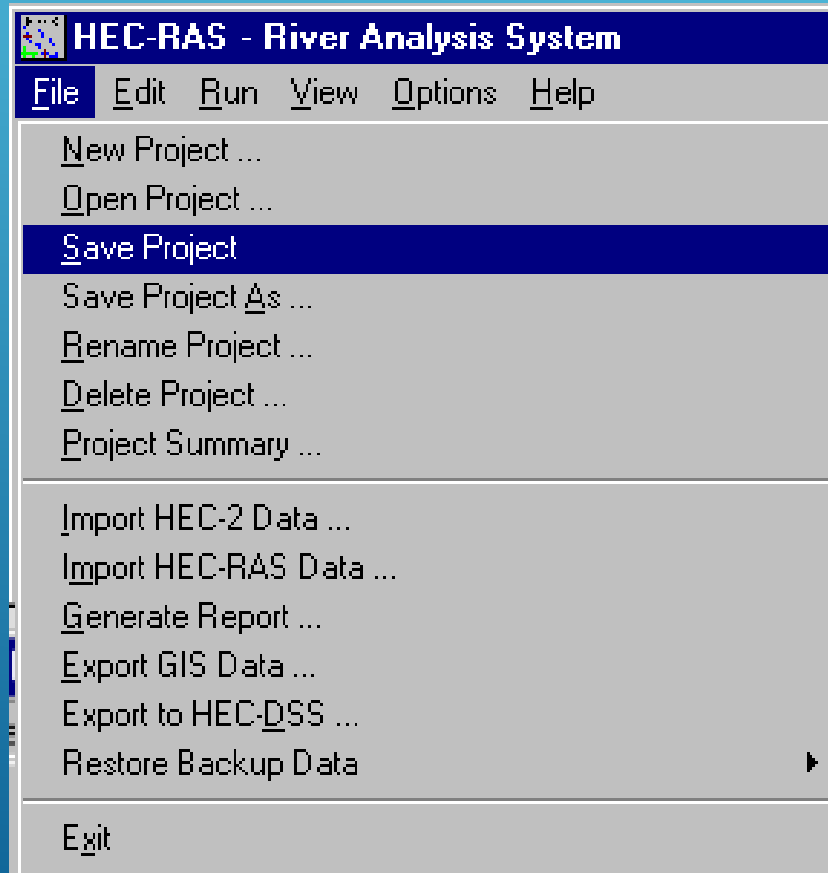

# PERFORM THE HYDRAULIC COMPUTATIONS

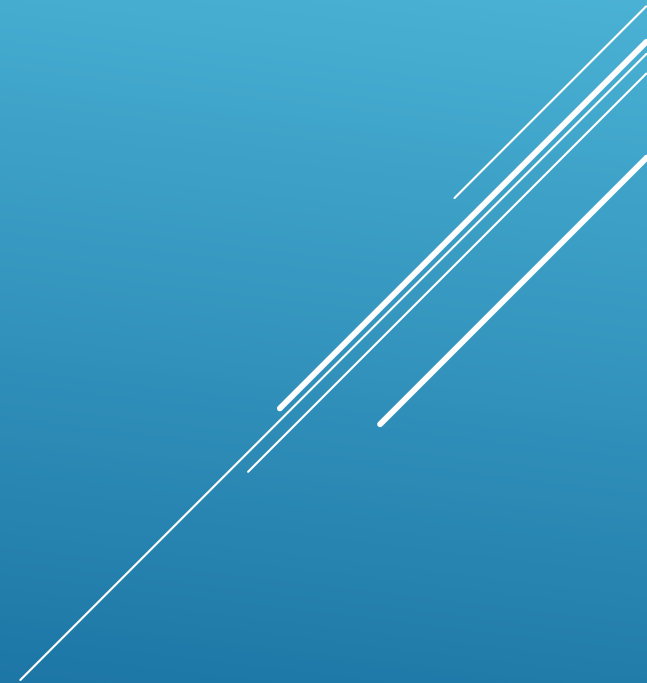

# PERFORM THE HYDRAULIC COMPUTATIONS

Enter the Steady Flow Analysis window from the main menu

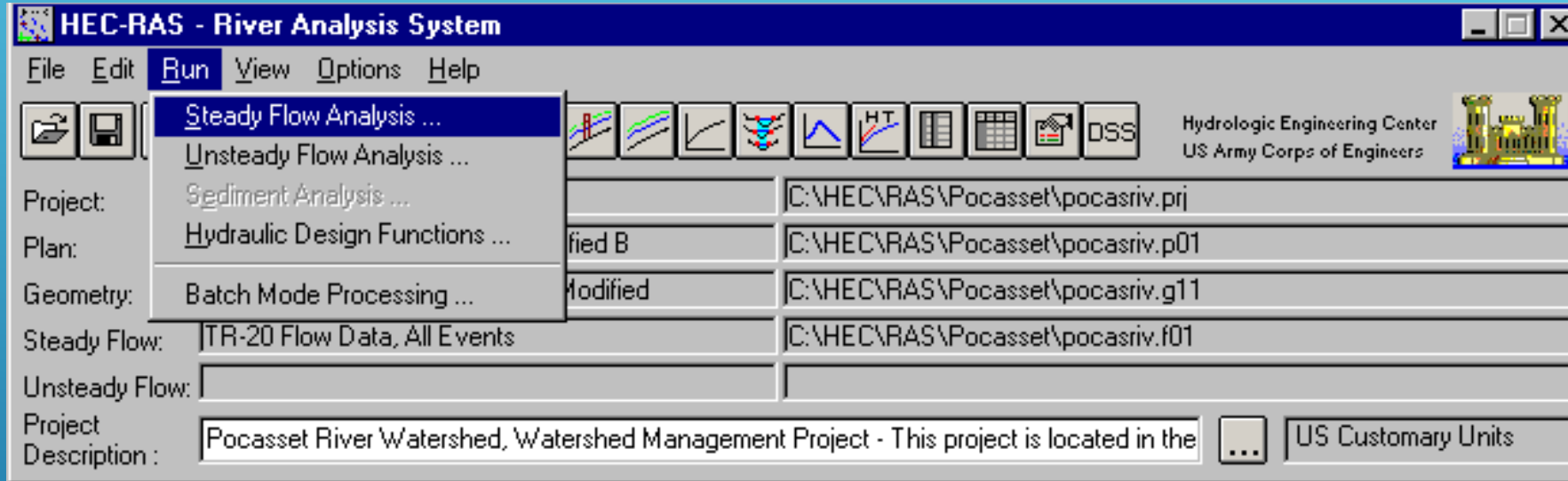

or select the Steady Flow Analysis button:

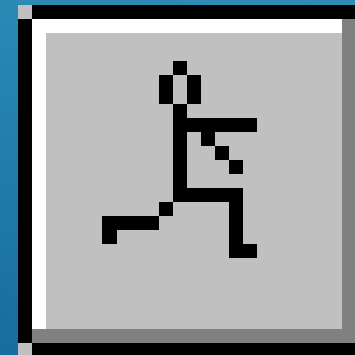

# PERFORM THE HYDRAULIC COMPUTATIONS

This brings up window where you can set flow regime, select geometry and/or flow files, and start the computations.

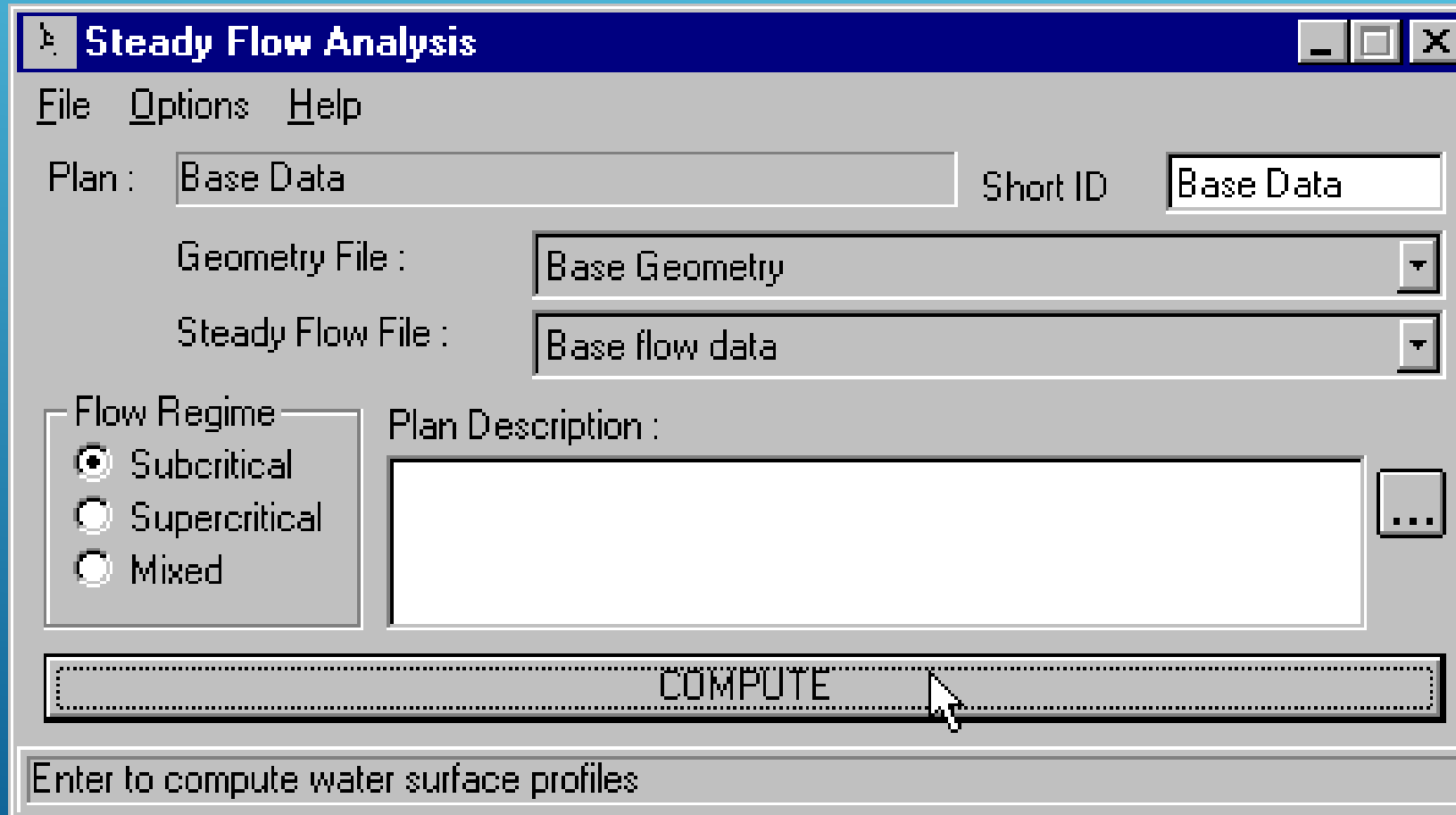

# SAVE PLAN

- Under "File", select "Save Plan As..."
- Create a project title.

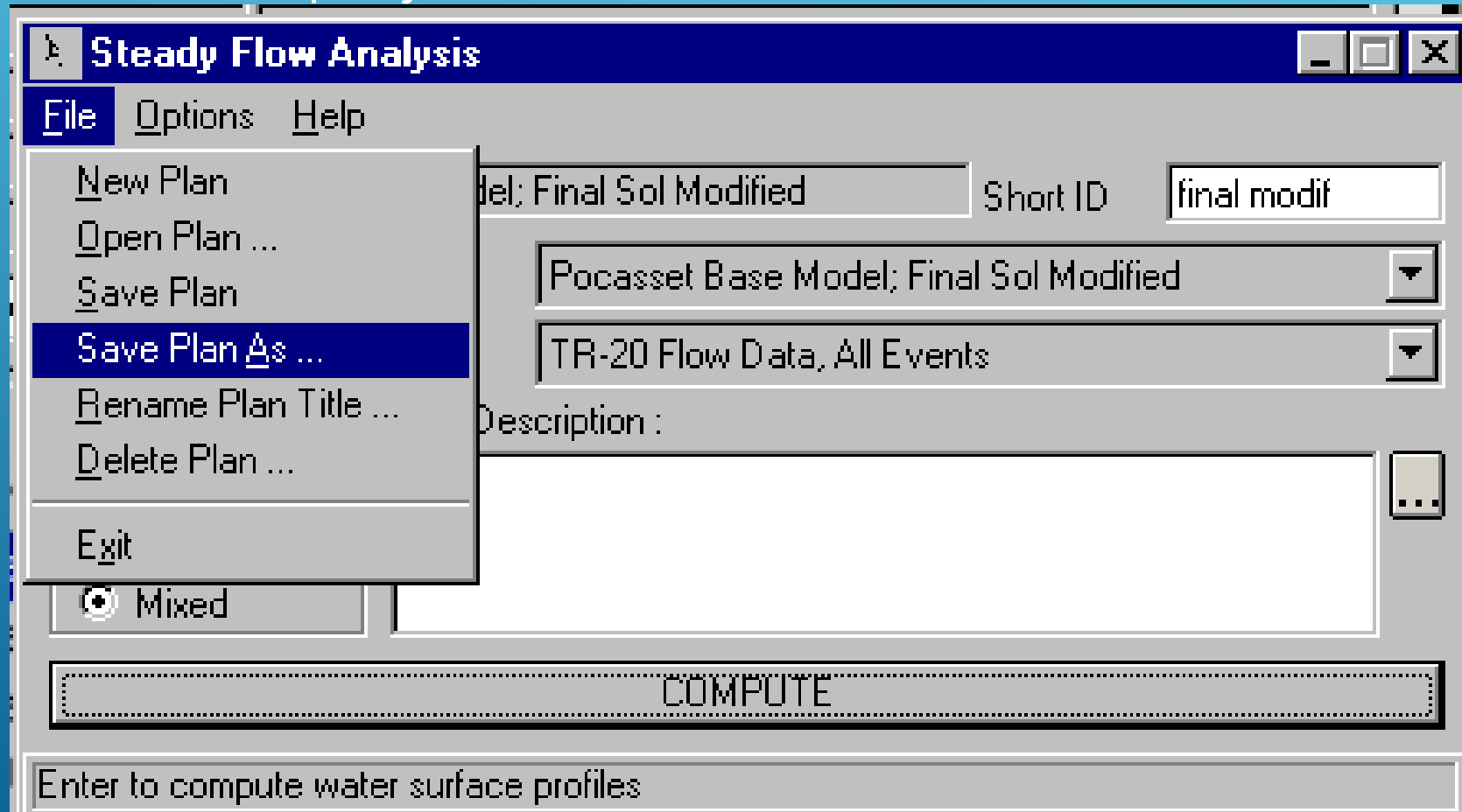

# SAVE PLAN

After selecting "OK", it brings up a window allowing you to enter a short plan identifier. This is used in printouts and reports by HEC-RAS.

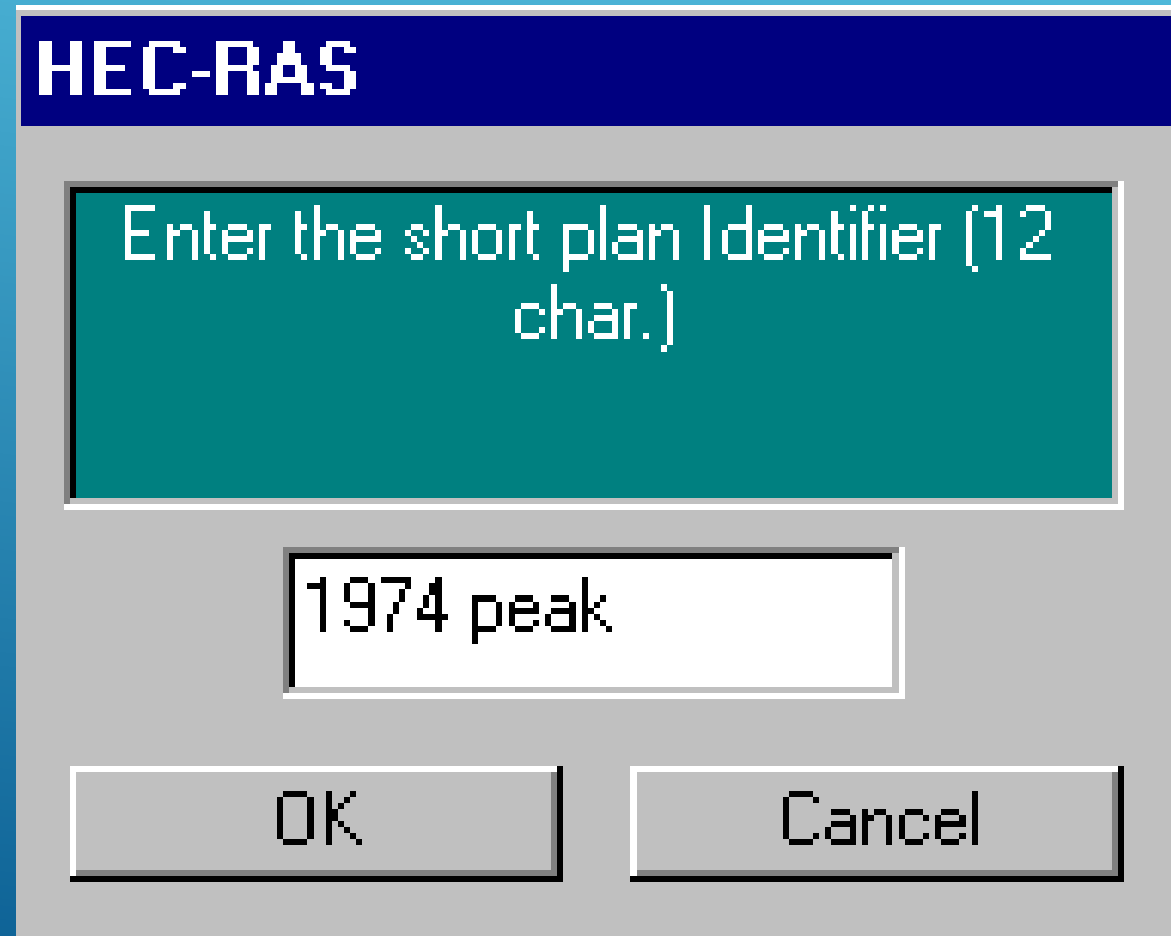

# PERFORM THE HYDRAULIC COMPUTATIONS

There are several options available for the hydraulic computations:

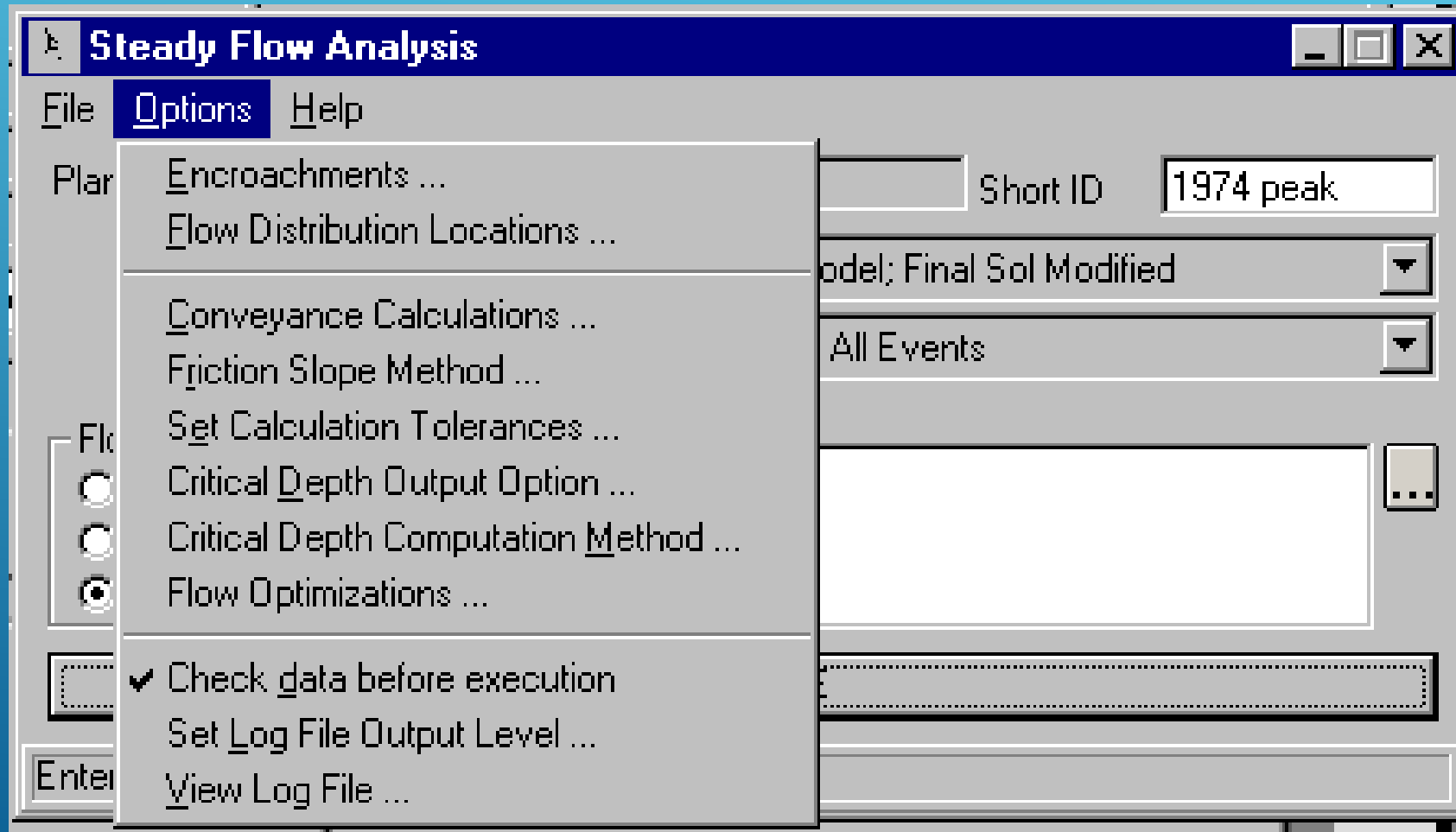

# PERFORM THE HYDRAULIC COMPUTATIONS

After selecting the compute button, HECRAS does it's magic

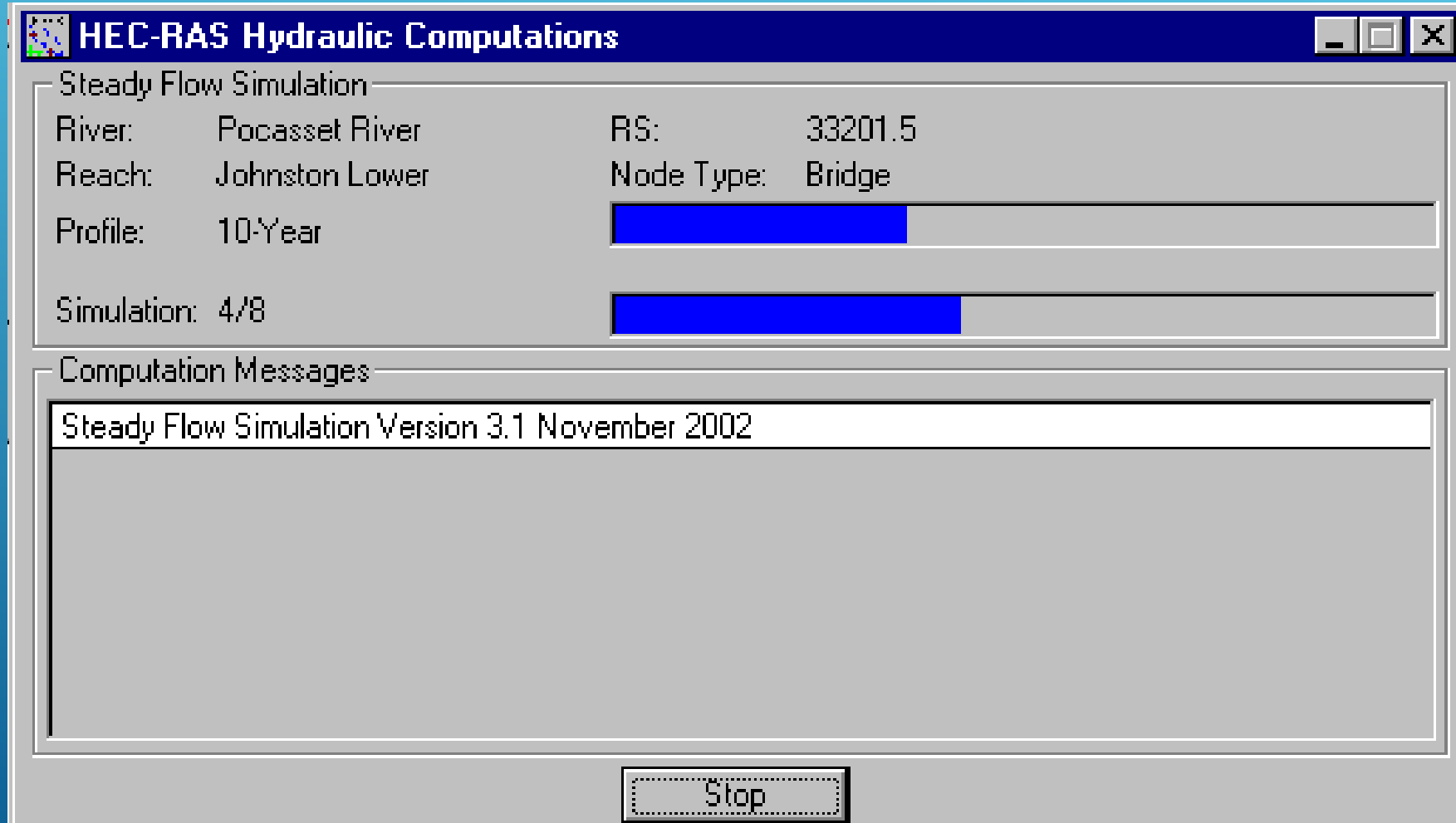

# VIEWING THE OUTPUT

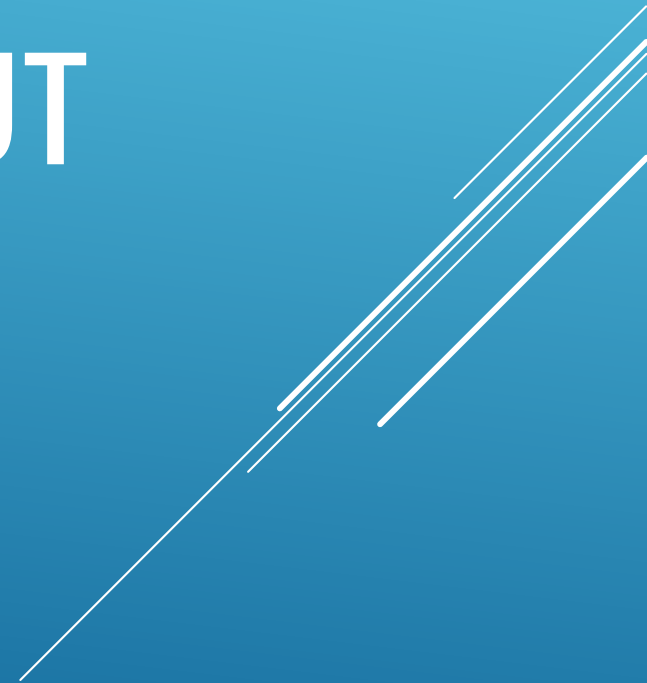

# VIEW THE OUTPUT

There are several output formats to view within the view menu such as plotted cross-sections, profiles, rating curves and 3-D views as well as cross-section and profile tabular data.

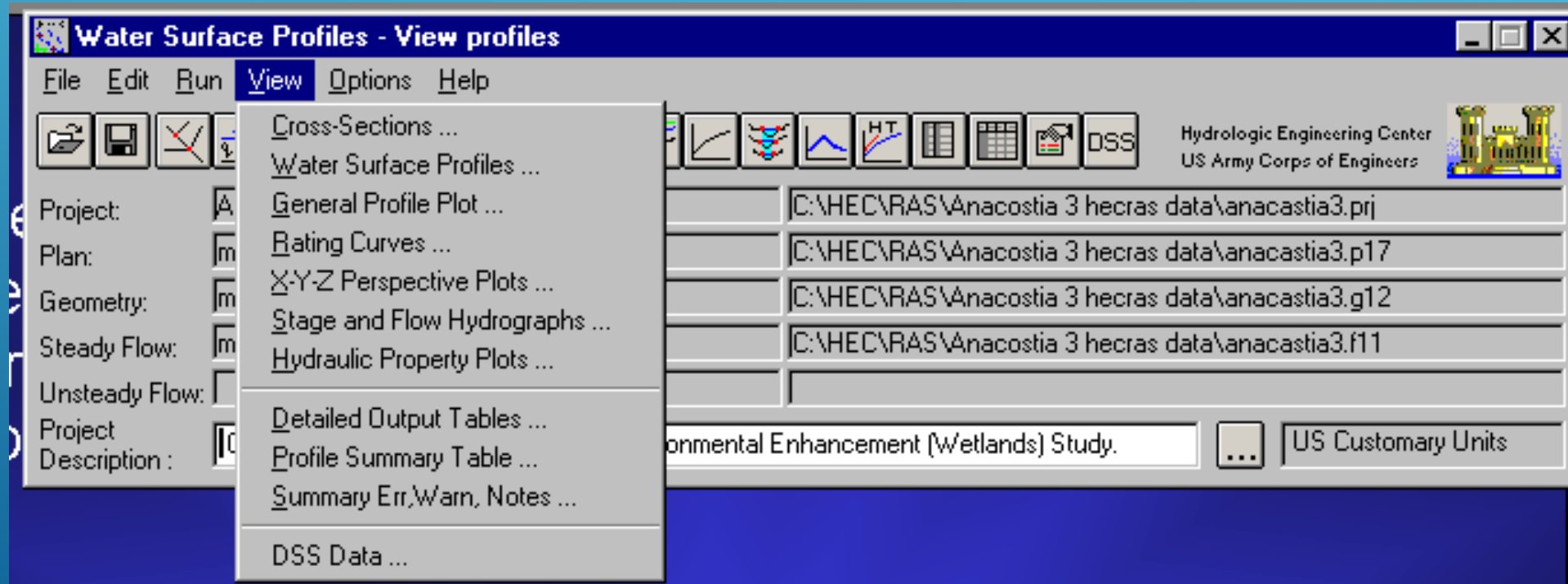

# VIEW THE OUTPUT

Or, you can select the appropriate button:

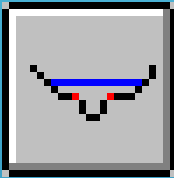

View Cross-Sections

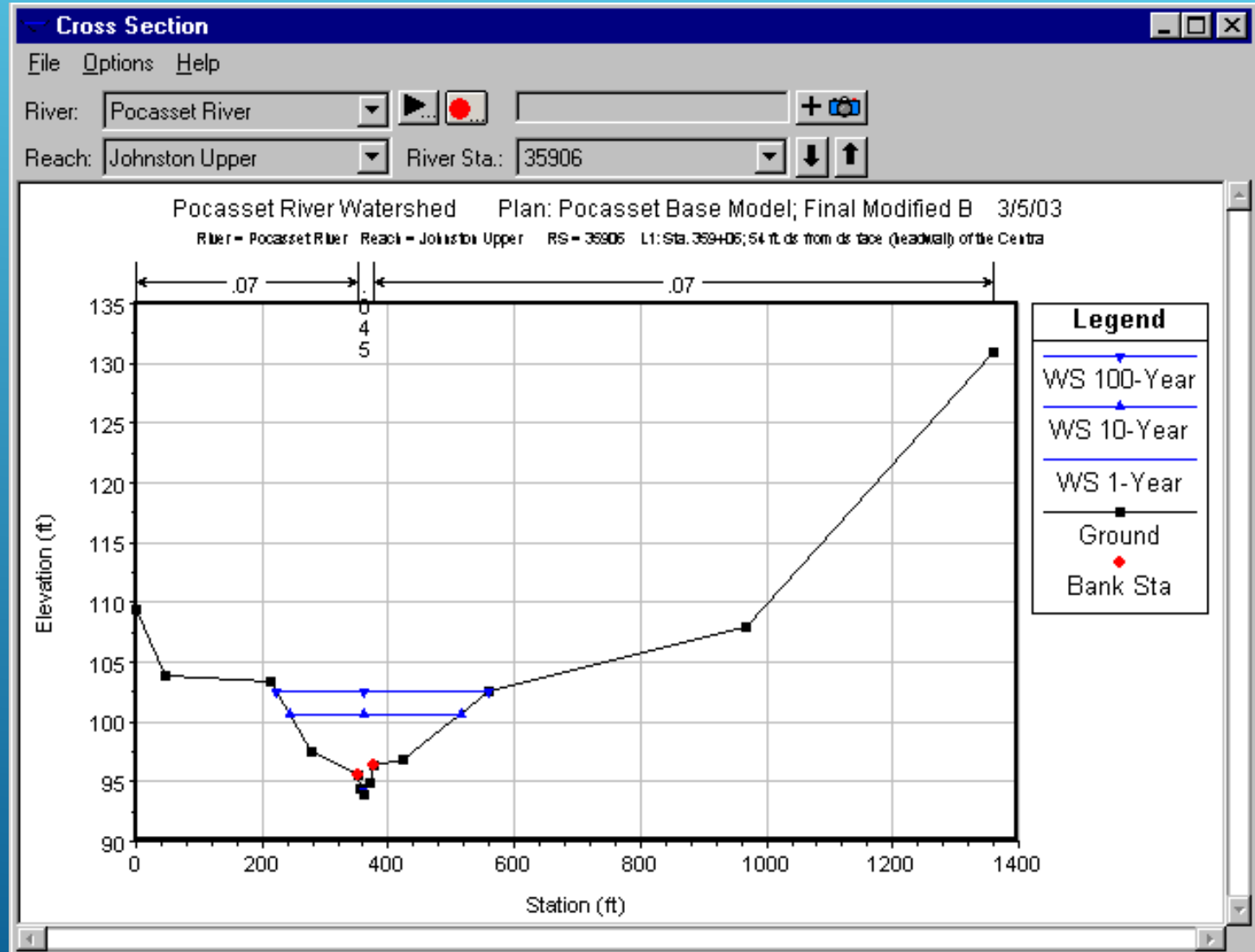

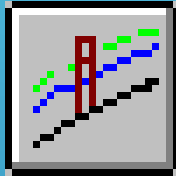

Plot Profiles

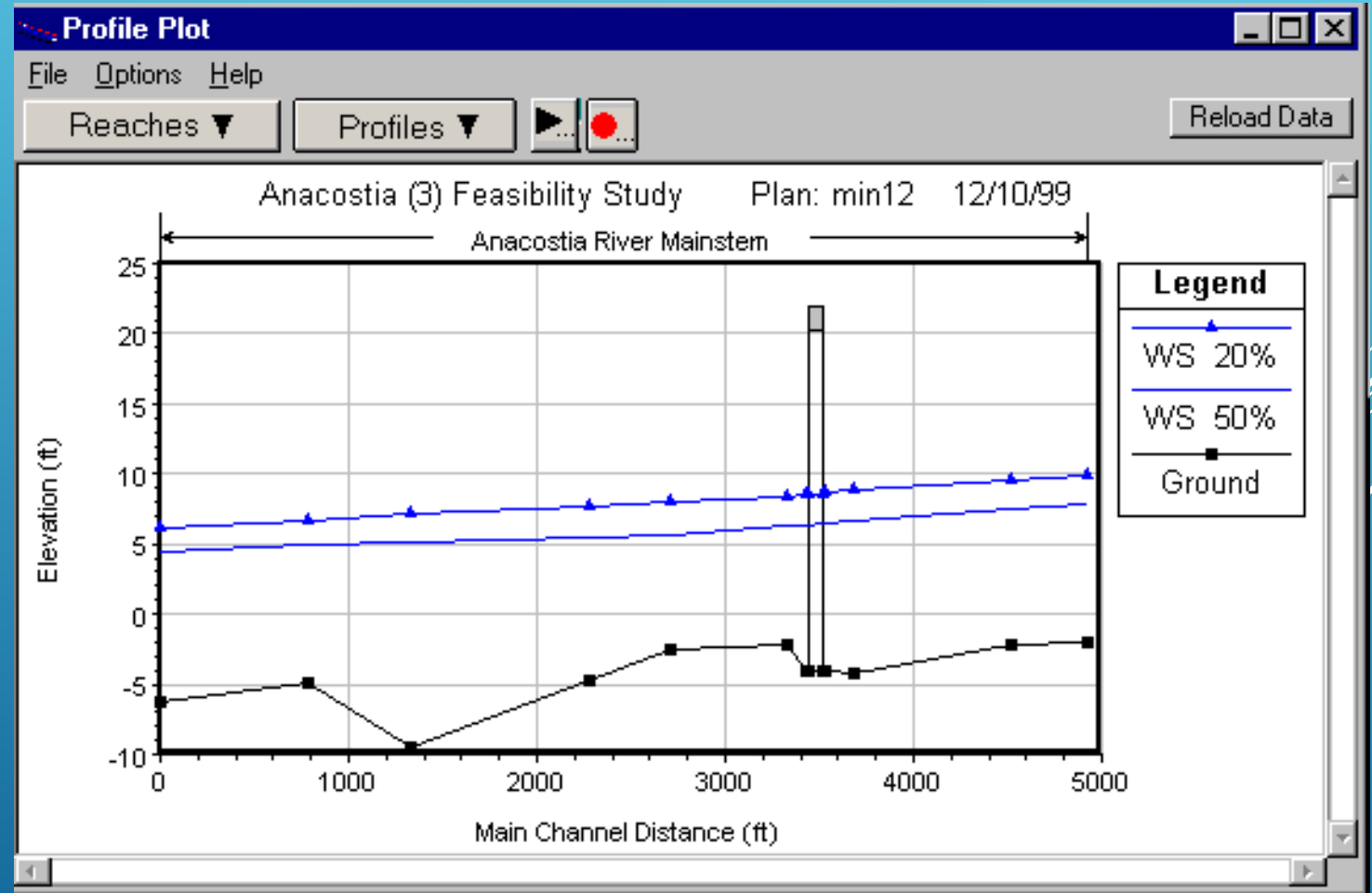

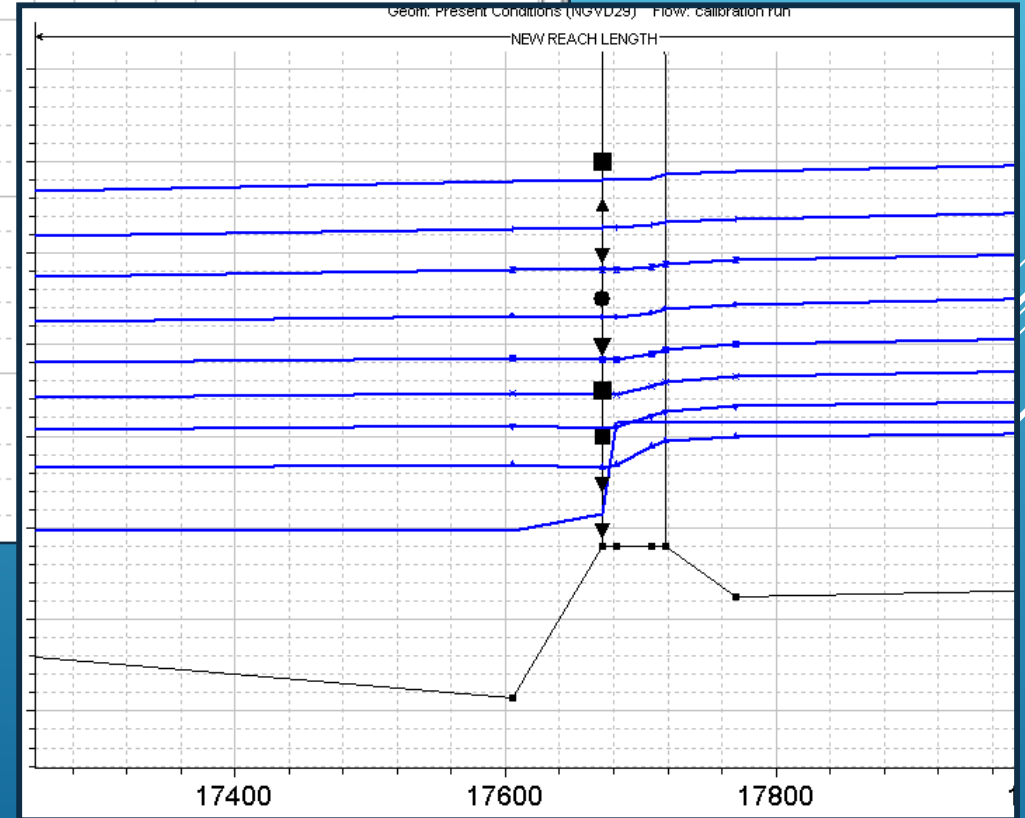
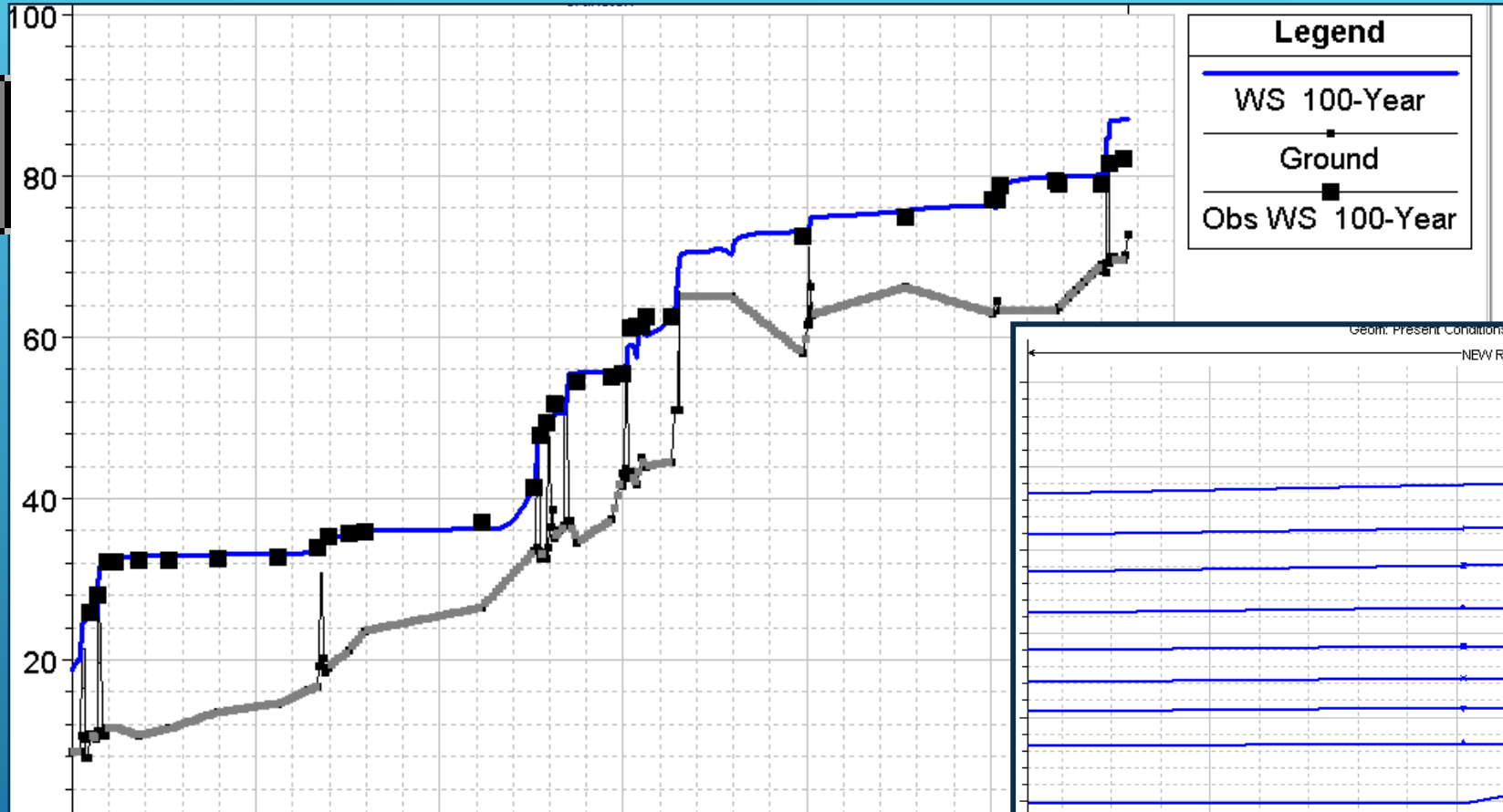
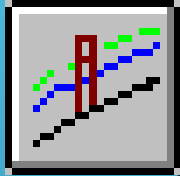

- See observed water surface profiles when you plot the profile
- Note source of data

# VIEW THE OUTPUT

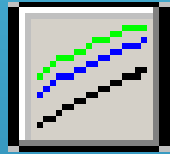

Plot profiles of different data

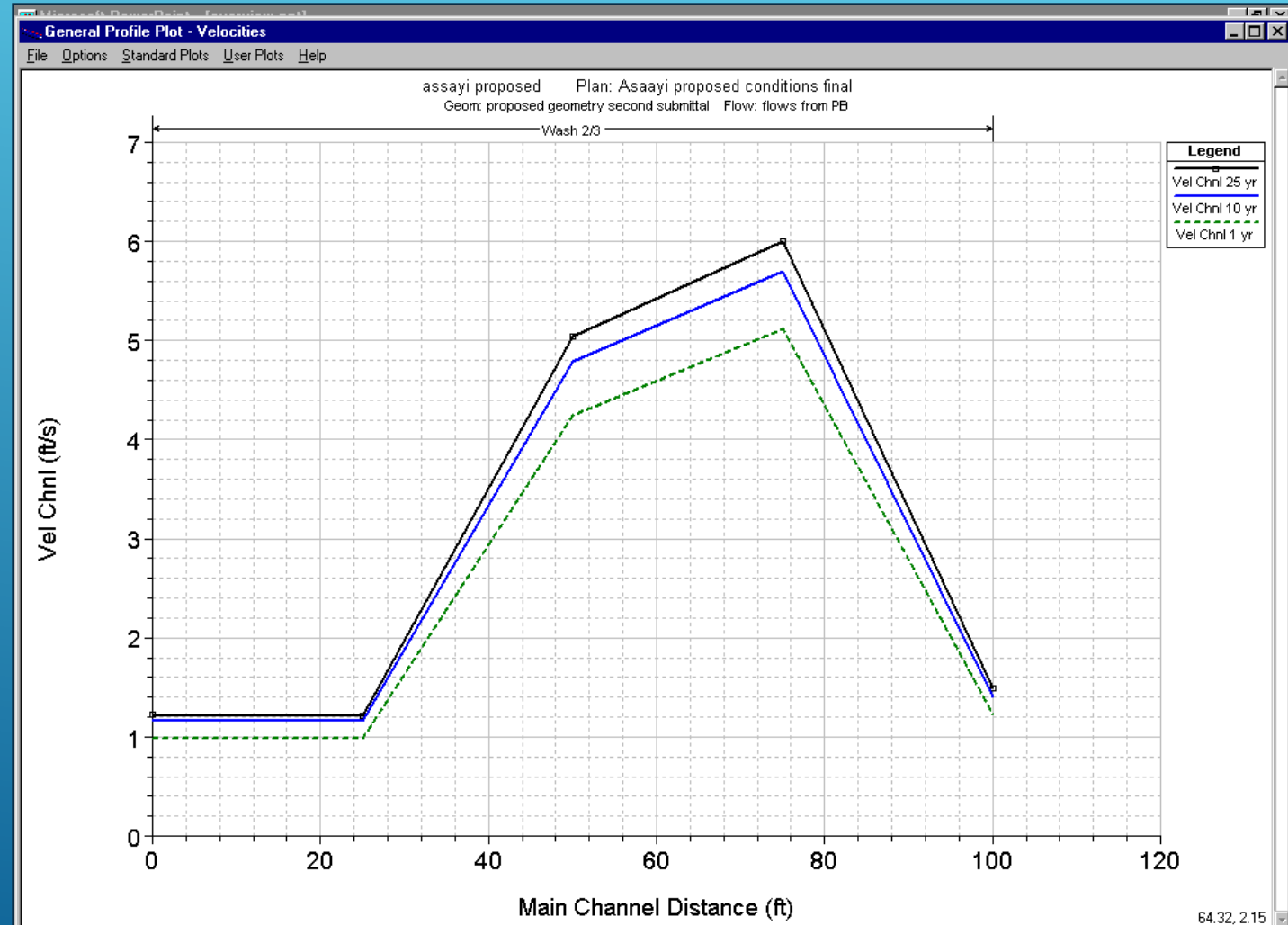

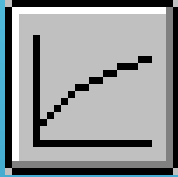

- Plot  
Rating  
Curves

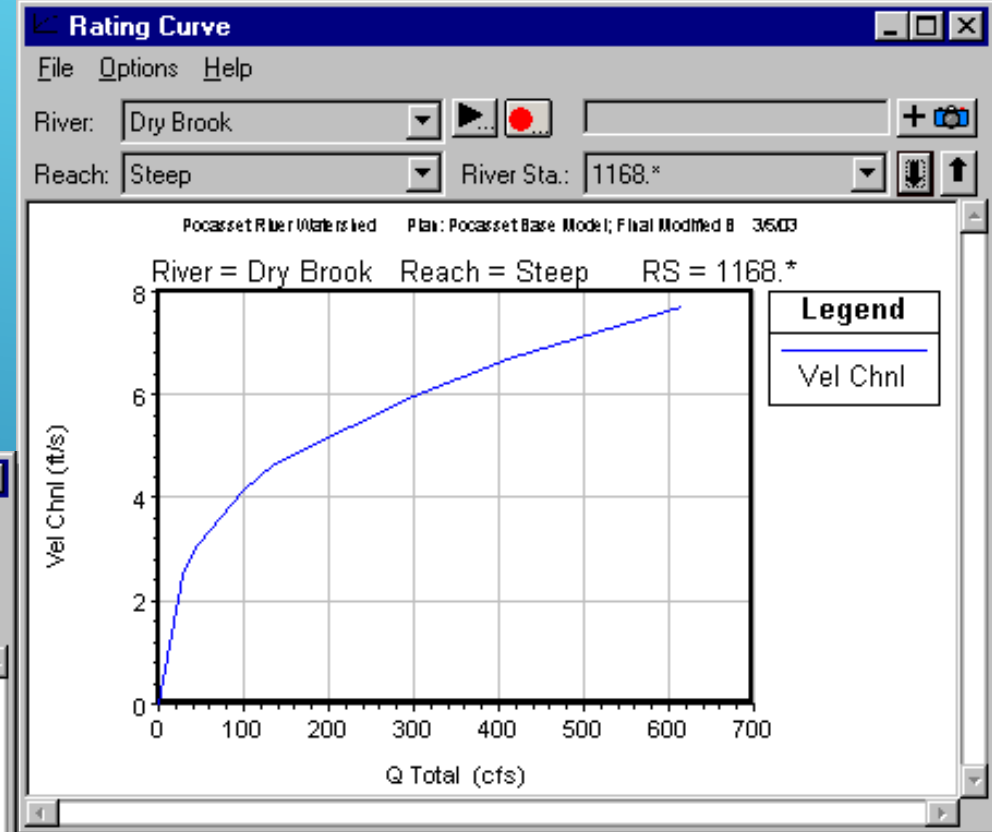
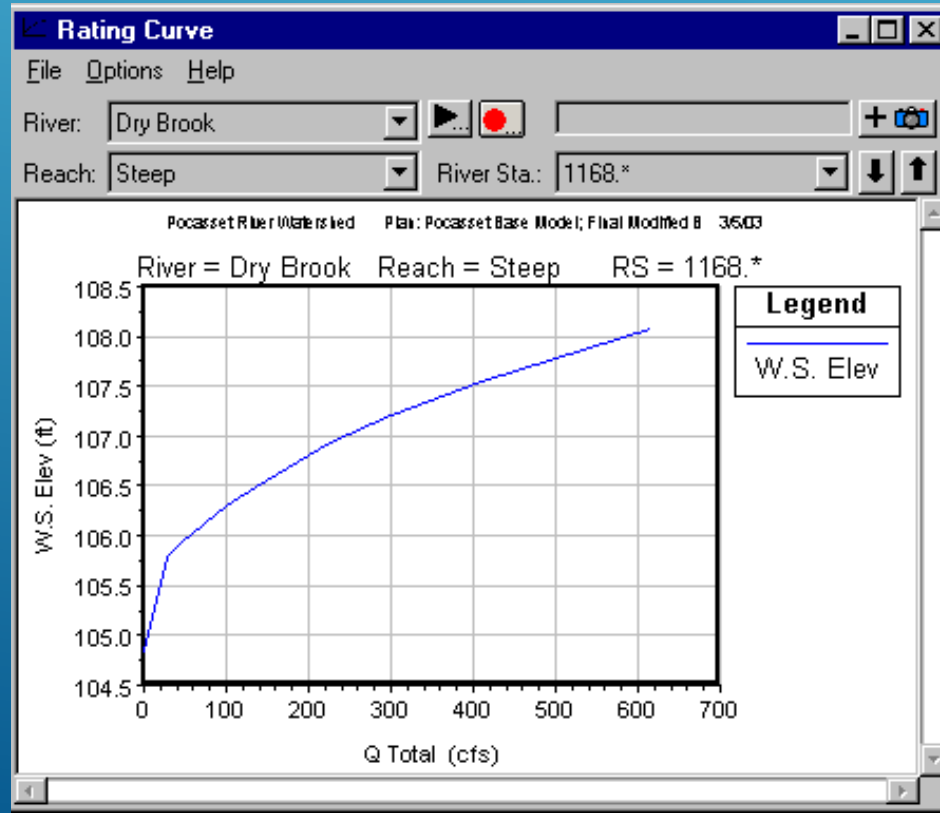



## Plot 3-D View

### Note:

Cross-section widths should be consistent for better presentation.

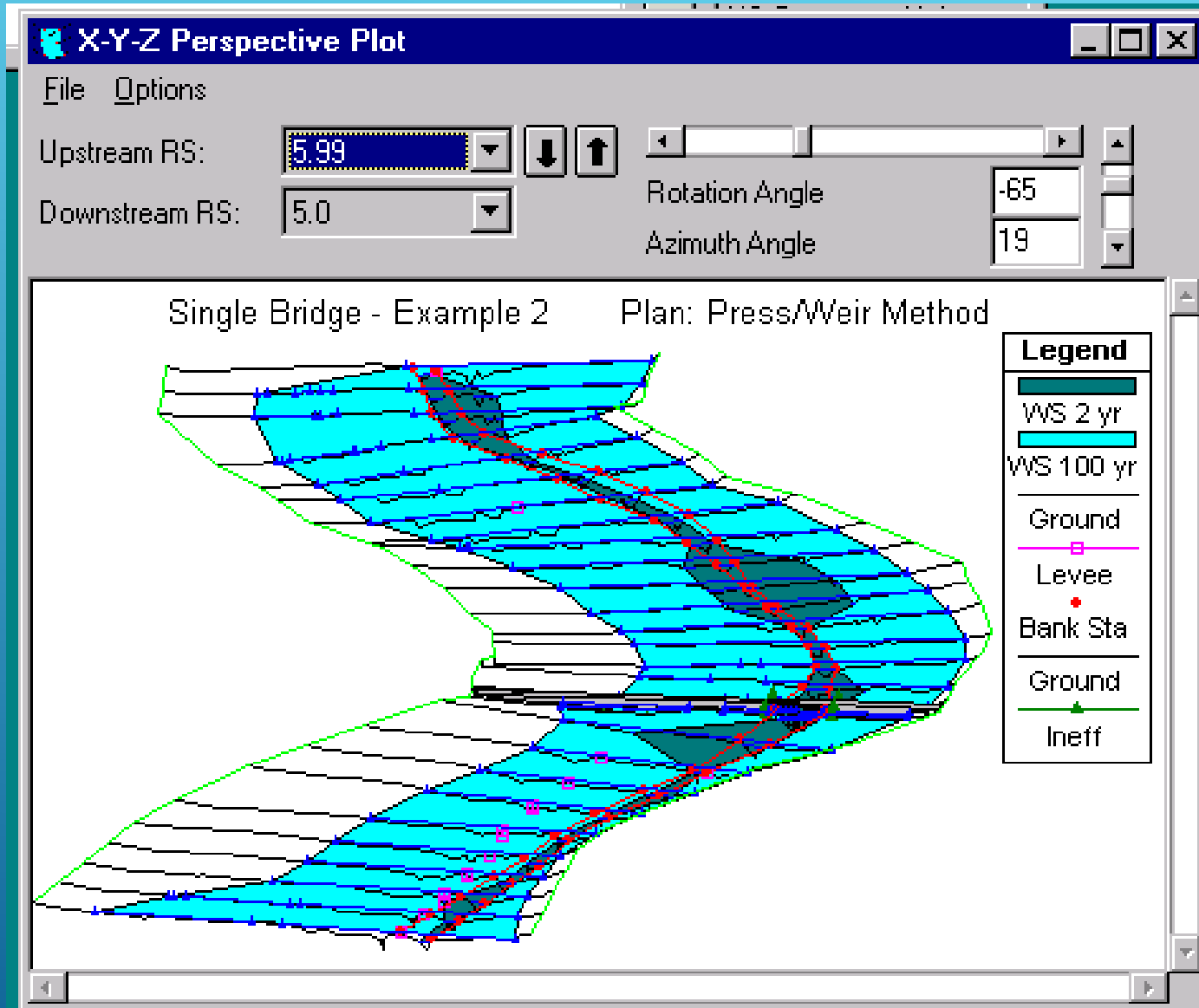

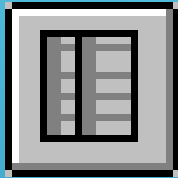

## View Cross-Section Table

Cross Section Output					
File Type Options Help					
River:	seeley creek	Profile:	1.1 yr		
Reach:	study reach	RS:	6.9	Plan:	Plan 01
Plan: Plan 01 seeley creek study reach RS: 6.9 Profile: 1.1 yr					
E.G. Elev (ft)		Element	Left OB	Channel	Right OB
Vel Head (ft)	0.16	Wt. n-Val.	0.075	0.050	0.080
W.S. Elev (ft)	1121.92	Reach Len. (ft)	0.00	0.00	0.00
Crit W.S. (ft)	1120.59	Flow Area (sq ft)	10.65	149.94	13.76
E.G. Slope (ft/ft)	0.004521	Area (sq ft)	10.65	149.94	13.76
Q Total (cfs)	522.00	Flow (cfs)	15.34	490.06	16.61
Top Width (ft)	92.89	Top Width (ft)	9.19	69.35	14.35
Vel Total (ft/s)	2.99	Avg. Vel. (ft/s)	1.44	3.27	1.21
Max Chl Dpth (ft)	4.32	Hydr. Depth (ft)	1.16	2.16	0.96
Conv. Total (cfs)	7763.8	Conv. (cfs)	228.1	7288.7	247.0
Length Wtd. (ft)	0.00	Wetted Per. (ft)	9.48	71.67	14.48
Min Ch El (ft)	1117.60	Shear (lb/sq ft)	0.32	0.59	0.27
Alpha	1.13	Stream Power (lb/ft s)	0.46	1.93	0.32
Froth Loss (ft)		Cum Volume (acre-ft)	5.39	15.99	3.87
C & E Loss (ft)		Cum SA (acres)	9.21	11.27	3.62
Errors, Warnings and Notes					
Enter to move to next downstream river station location					

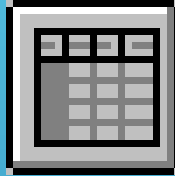

View Profile Table

**Profile Output Table - Standard Table 1**

File Options Std. Tables Locations Help

HEC-RAS Plan: mod1 River: Mill Creek Reach: project area Reload Data

Reach	River Sta	Profile	Q Total (cfs)	Min Ch El (ft)	W.S. Elev (ft)	Crit W.S. (ft)	E.G. Elev (ft)	E.G. Slope (ft/ft)	V
project area	100	500cfs	500.00	418.20	421.76		421.95	0.001709	
project area	100	2000cfs	2000.00	418.20	425.53		425.96	0.001791	
project area	100	7000cfs	7000.00	418.20	431.76		432.59	0.001766	
project area	99.5*	500cfs	500.00	418.03	421.59		421.77	0.001713	
project area	99.5*	2000cfs	2000.00	418.03	425.36		425.79	0.001794	
project area	99.5*	7000cfs	7000.00	418.03	431.59		432.42	0.001767	

Total flow in cross section.

Under “Options”, select “Define Table” to see more variables

**Create a Table Heading**

Select Variables | Additional Options

Table Column Headings					
Column	1	2	3	4	5
Variable	Q Total	Min Ch El	W.S. Elev	Crit W.S.	E.G. Elev
Units	(cfs)	(ft)	(ft)	(ft)	(ft)
Decimal Pts	2	2	2	2	2

Delete Column | Insert Column | Clear All Table Headings

Available Variables				
# Barrels	Base WS	Center Station	Conv. Left	Crit Enrgy 1
Alpha	Beta	Ch Sta L	Conv. Ratio	Crit Enrgy 2
Area	BR Open Area	Ch Sta R	Conv. Right	Crit Enrgy 3
Area Channel	BR Open Vel	Clv EG No Wr	Conv. Total	Crit Num
Area Left	Br Sel Method	Coef of Q	Crit Depth	Crit W.S.
Area Right	C & E Loss	Conv. Chnl	Crit E.G.	Crit W.S. 1



- Summary of Errors, Warnings, & Notes

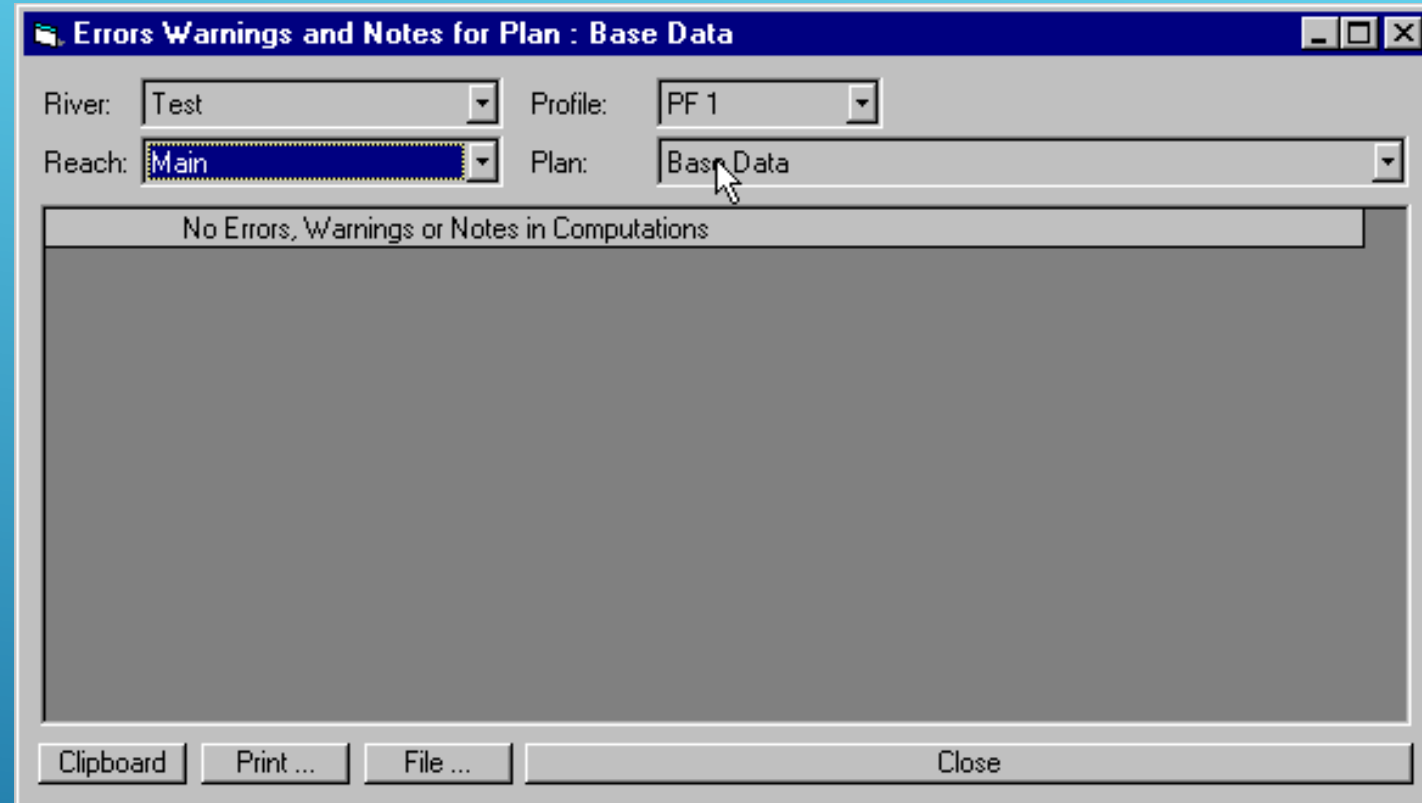

Errors: problems that prevents the program from running. The user must change something.

Warnings: does not prevent the program from running but the user should examine and review. The user may want to change some input.

Notes: provides information about how the program is performing the calculations, user should review

You can select  
“Generate Report  
...” from the HEC-  
RAS main menu.

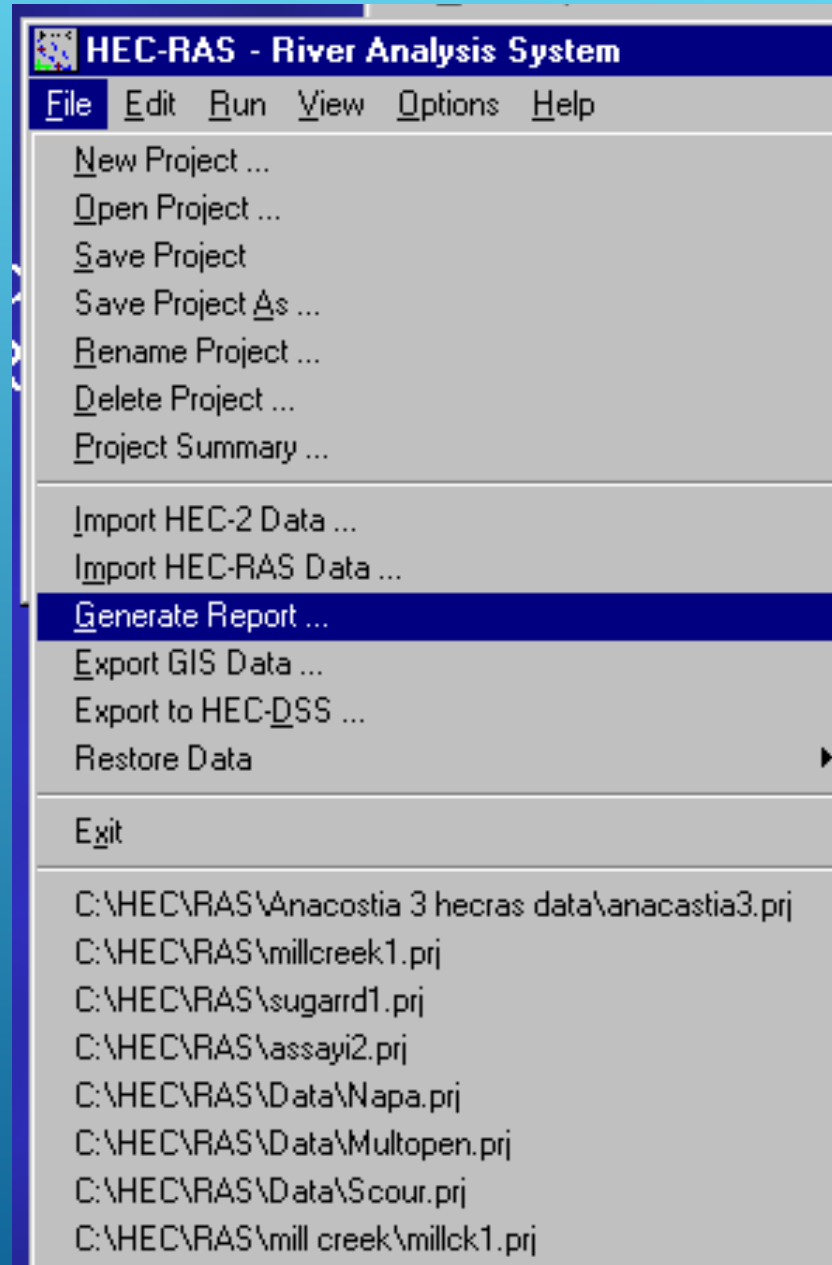

There are several options available for the report content. The report generated can be viewed or the resulting file printed.

**Report Generator**

Report file:  Asterisks for Borders ▼

**Input Data**

<u>General</u>	<u>Summary</u>
<input checked="" type="checkbox"/> Plan Data	<input checked="" type="checkbox"/> Manning's n Values
<input checked="" type="checkbox"/> Flow Data	<input checked="" type="checkbox"/> Reach Lengths
<input checked="" type="checkbox"/> Geometric Data	<input checked="" type="checkbox"/> Contr. and Expan. Coefficients

**Output**

Profiles to Include in Report:  Set Profiles

Specific Tables (Detailed Output)

<input checked="" type="checkbox"/> Cross Section Table	<input type="checkbox"/> Lateral Weir Table
<input type="checkbox"/> Culvert Table	<input type="checkbox"/> Storage Area
<input type="checkbox"/> Bridge Table	<input type="checkbox"/> Storage Area Connection
<input type="checkbox"/> Multiple Openings	<input type="checkbox"/> Pump Stations
<input type="checkbox"/> Inline Weir Table	<input type="checkbox"/> Flow Distribution

Profile Tables (Summary Output)

Available Summary Tables	Selected Summary Tables
<input type="text" value="Standard Table 1"/> <span style="border: 1px solid black; padding: 2px;">▼</span>	<input type="text" value="Standard Table 1"/>
<input type="text" value="Standard Table 2"/> <span style="border: 1px solid black; padding: 2px;">▼</span>	

Summary of Errors, Warnings and Notes

Close    Generate Report    View Report

# JUNCTIONS

- ⦿ Defined as two or more streams which come together or split apart.
- ⦿ Constructed by drawing reaches together to a common point. Draw the line representing the tributary in the direction the water will flow (the line ends at the main stream).
- ⦿ For splitting flow, draw lines in the direction water will flow.
- ⦿ Can be modeled using the energy equation or momentum equation.

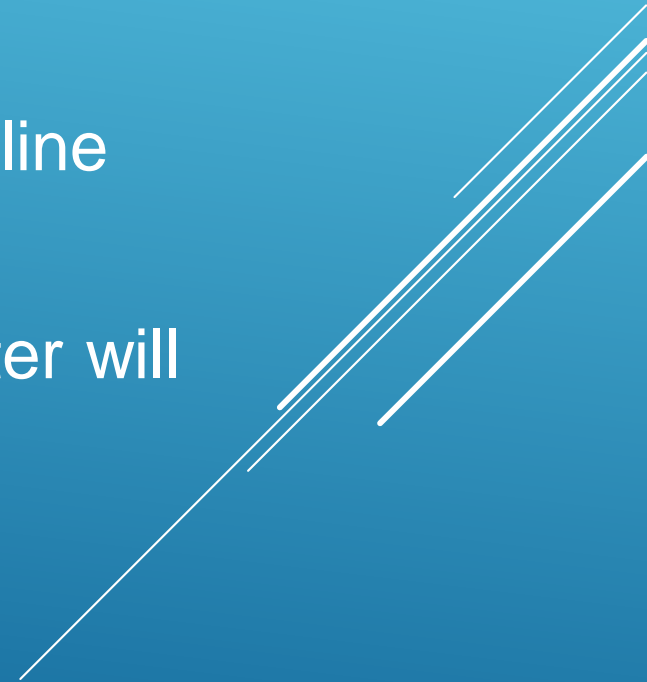

# JUNCTIONS - 6 TYPES

- ① Subcritical flow - flow combining
- ② Subcritical flow - flow splitting
- ③ Supercritical flow - flow combining
- ④ Supercritical flow - flow splitting
- ⑤ Mixed flow - flow combining
- ⑥ Mixed flow - flow splitting

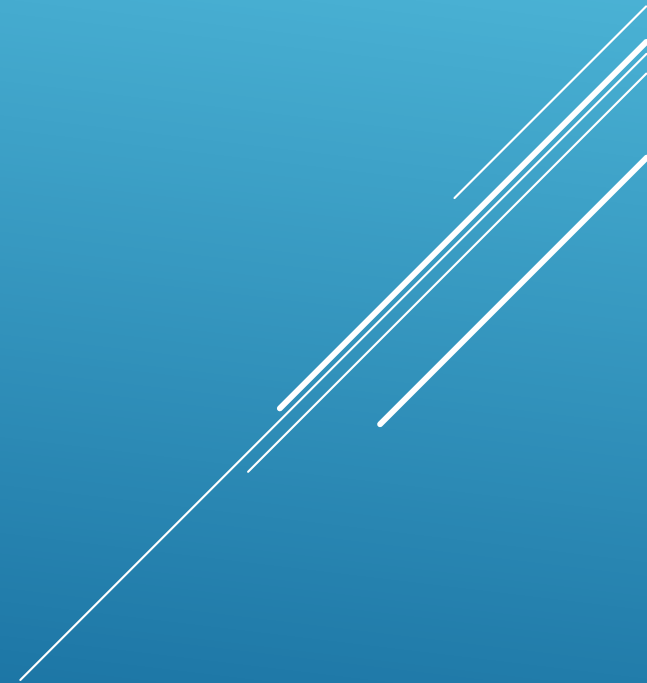

# JUNCTIONS

- Press the River Reach button and cursor turns to a pen.
- Hold down the left mouse button and draw in the direction of flow.
- Release and press left mouse button to change line direction (gives shape to the schematic).
- At the end of the reach double click the left mouse button. This will terminate the reach drawing.

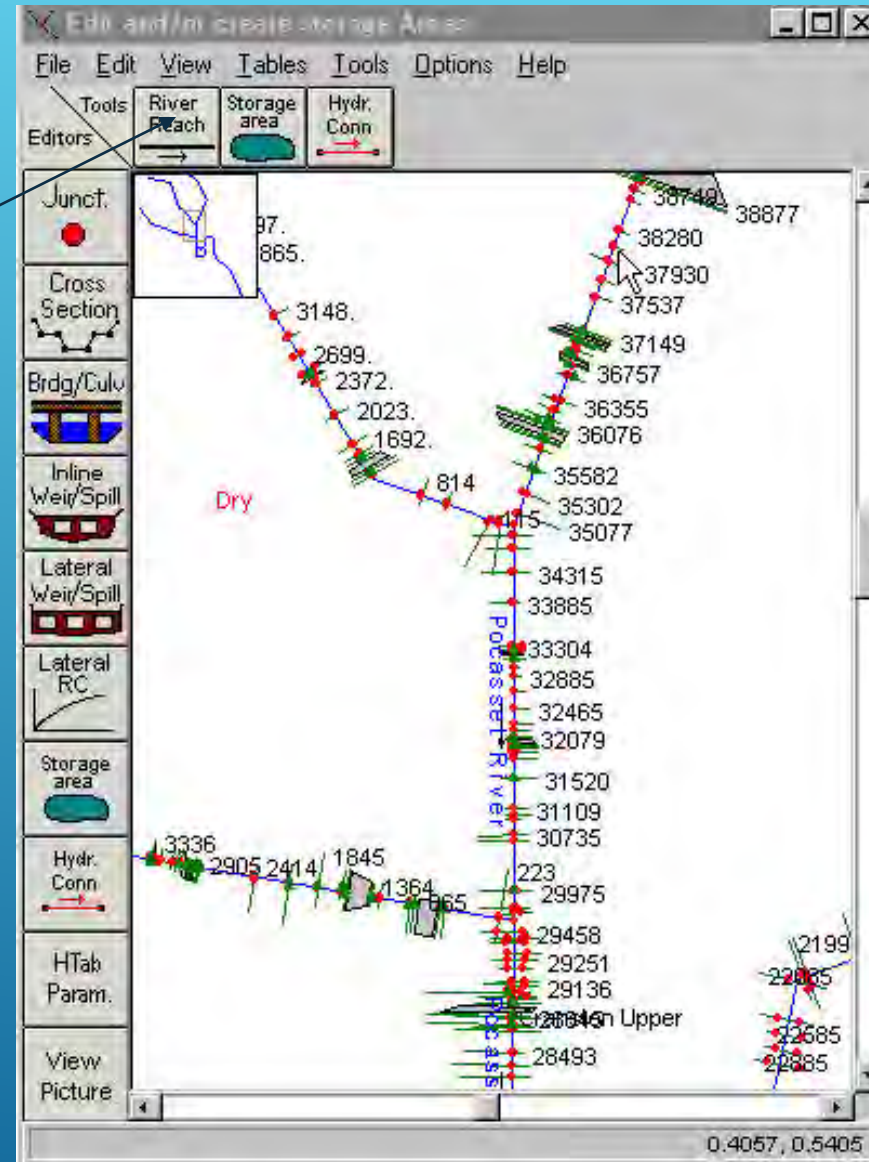

# DRAW FIRST RIVER REACH

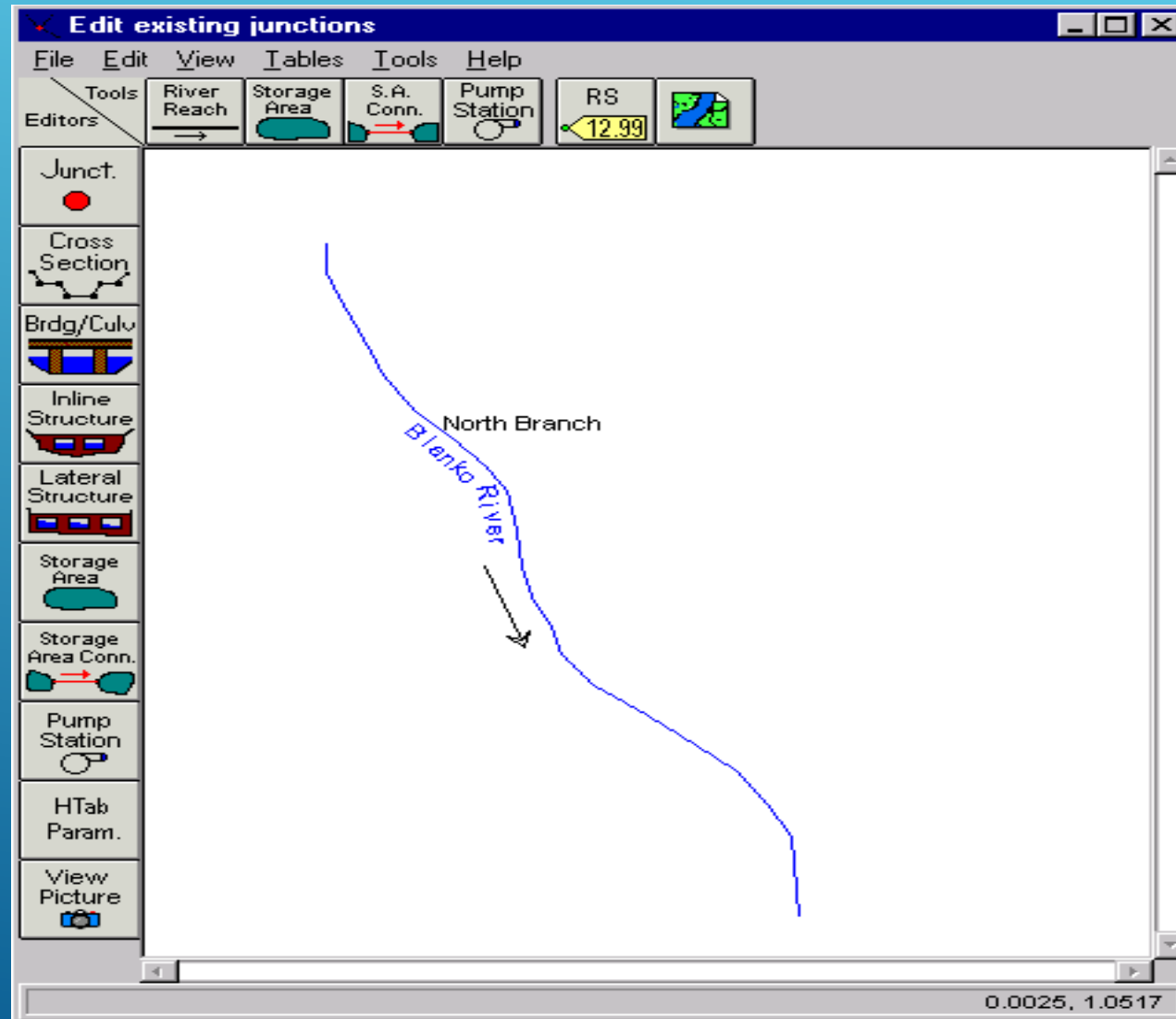

1.



Once the tributary to the mainstem is drawn, there is a sequence of data requirements (1 thru 4) for entering a tributary and junction

2.

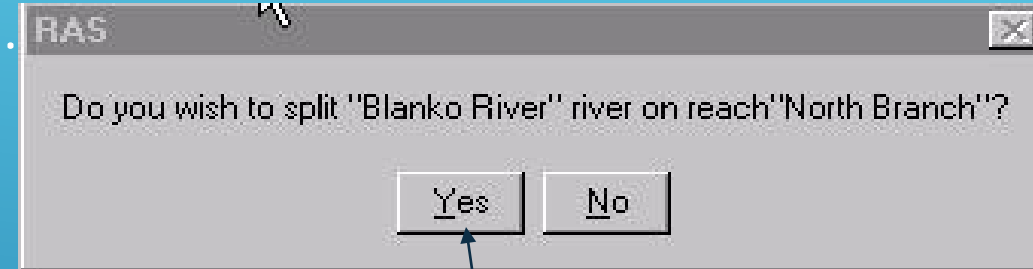

Select "Yes".

3.



4.

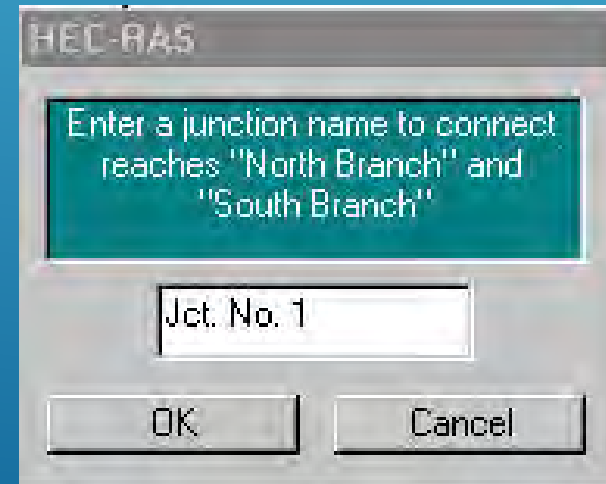

- Schematic of Blanko River with the Black Dog Creek tributary.
- Blanko River is split between the North Branch and South Branch at Junction No. 1

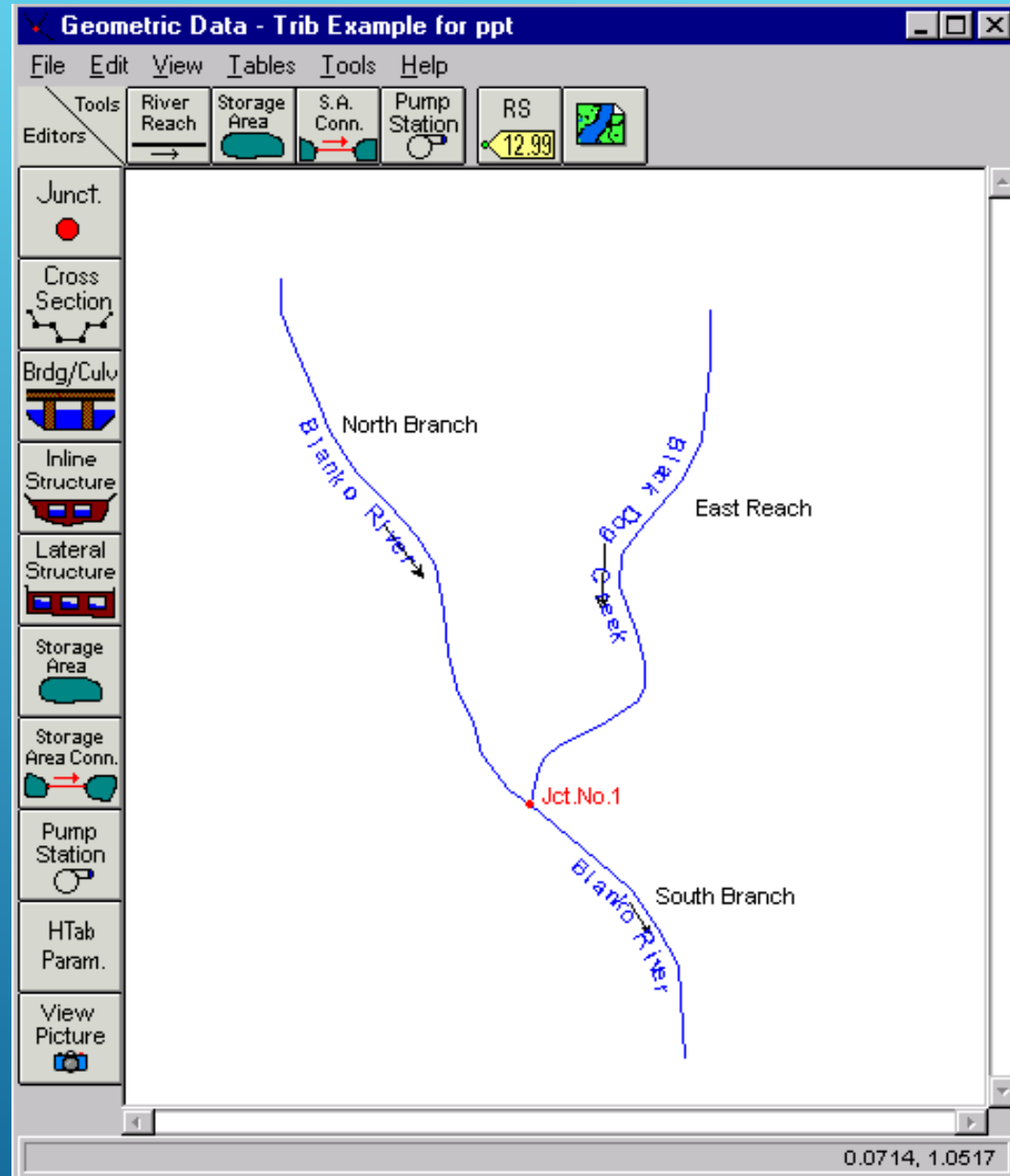

# JUNCTIONS

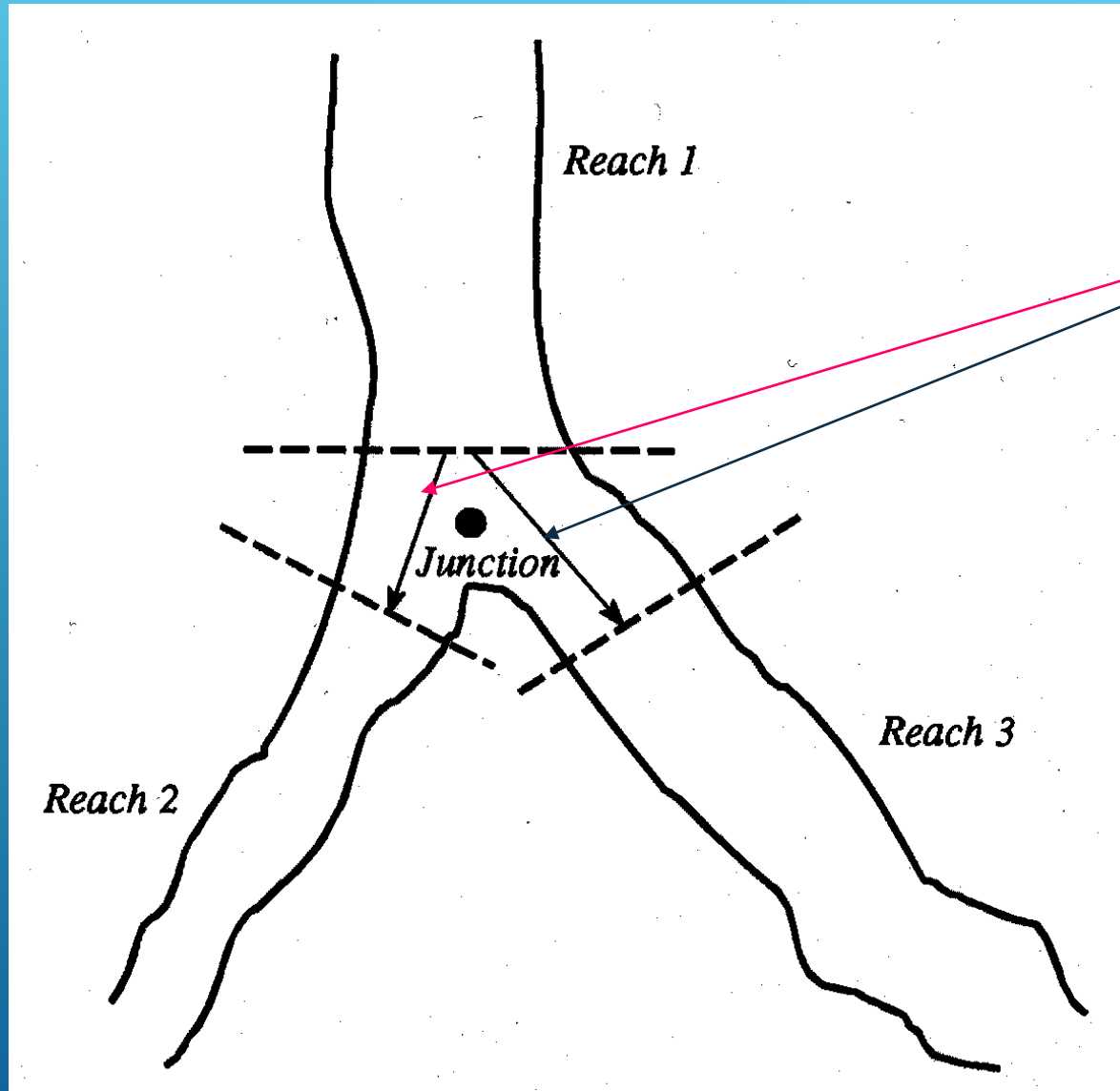

- Each of these reach lengths are entered in the Junction Data window.

- The downstream reach length shown on the upstream cross-section data window should be set to zero.

# JUNCTIONS - REACH LENGTHS

- ⦿ For cross sections upstream of the junction, the reach length should be zero.
- ⦿ Cross sections should be as close to the junction as possible.
- ⦿ Go into the Geometric Cross Section editor to change these lengths.
- ⦿ Distance across the junction is generally, the average distance that water will travel between cross sections across a junction.

# JUNCTIONS - ENERGY VS MOMENTUM

Where angle of tributary can cause significant energy losses, it is more appropriate to use the momentum equation.

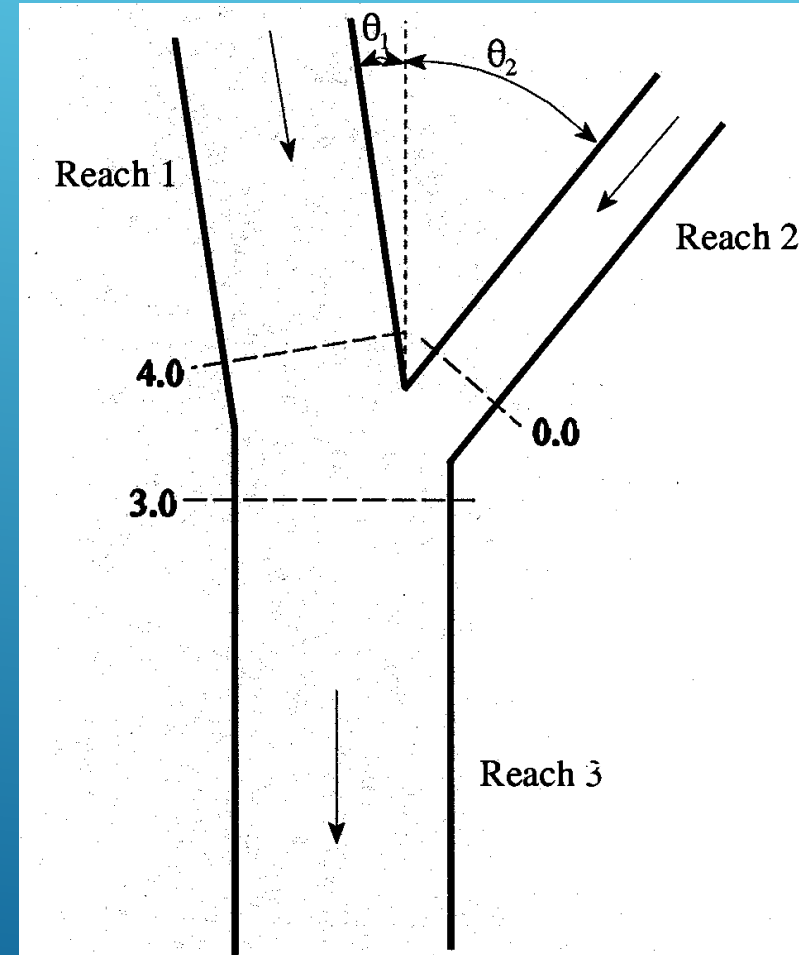
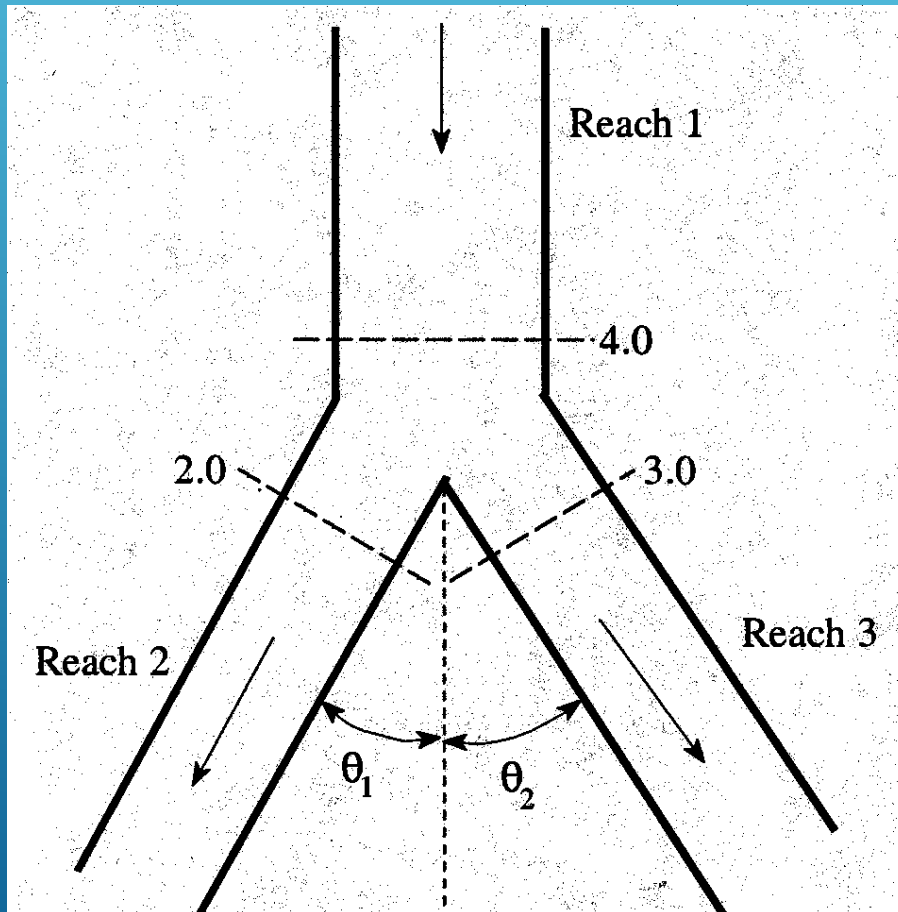

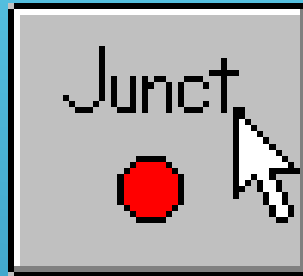

or, point the mouse at the junction, left click and select "Edit Junction".

**Junction Data**

Junction Name: Jct. No. 1 [Dropdown] [Down Arrow] [Up Arrow] [Apply Data]

Description: [Text Field] [Ellipsis]

Computation Mode:  
 Energy  
 Momentum  
 Add Friction  
 Add Weight

Length across Junction		Location
From: Blanko River - South Branch	Length (ft)	Angle (Deg)
To: Blanko River - North Branch	50	
To: Black Dog Creek - East Reach	40	

OK Cancel Help

Edit length across junction (ft)

# JUNCTIONS - SPLIT FLOWS

For split flows, i.e. when the stream is divided or split apart in the downstream direction, the program can optimize the amount of flow going in each direction. The user must estimate the initial flows going in each direction. It only is available for steady flow analysis.



# Junctions - Split Flows

The optimization is found under the steady flow analysis window .

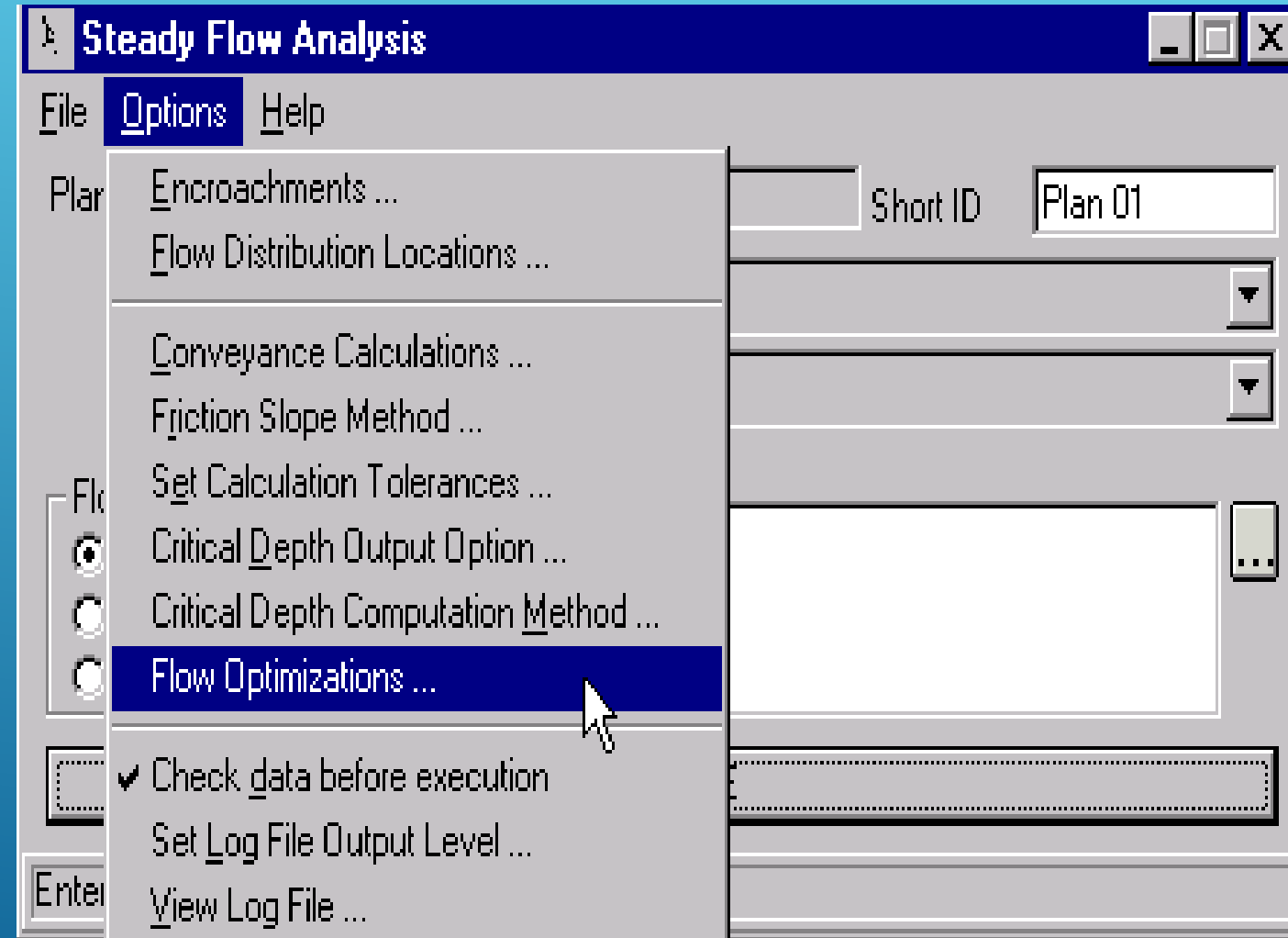

# Junctions - Split Flows

**Steady Flow Analysis - Flow Optimization Options**

Junctions | Lateral Weir/Diversions | Reach-Storage Areas | Pumps

Junctions	Optimize
1 wingwall	<input type="checkbox"/>

OK Cancel

# JUNCTIONS - CROSS SECTION LOCATIONS

## 3 Criteria for XS's near junctions:

- ⚡ Locate them close to junction. Another cross section may be transferred if representative.
- ⚡ Cross-Sections should not overlap (the ends may touch upstream of junction for example).
- ⚡ Should be located where flow is essentially one-dimensional.

# How does a bridge affect the hydraulics?

- Contraction
- Through the bridge
  - Piers
  - Abutments
  - Bridge deck
- Expansion

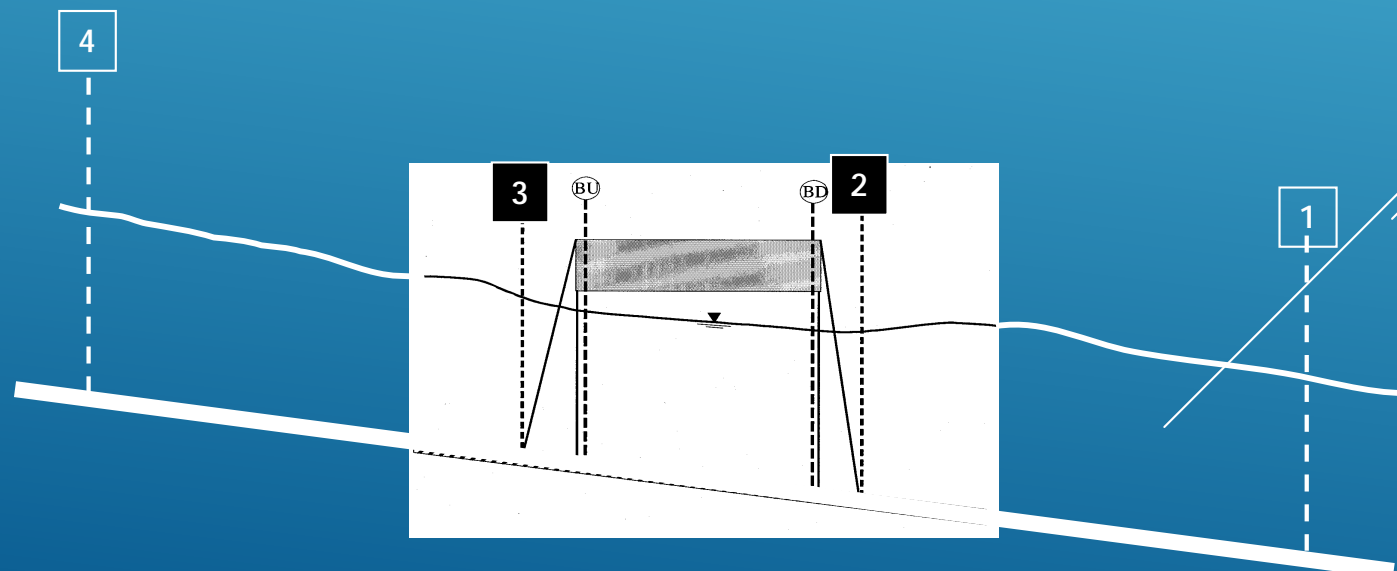
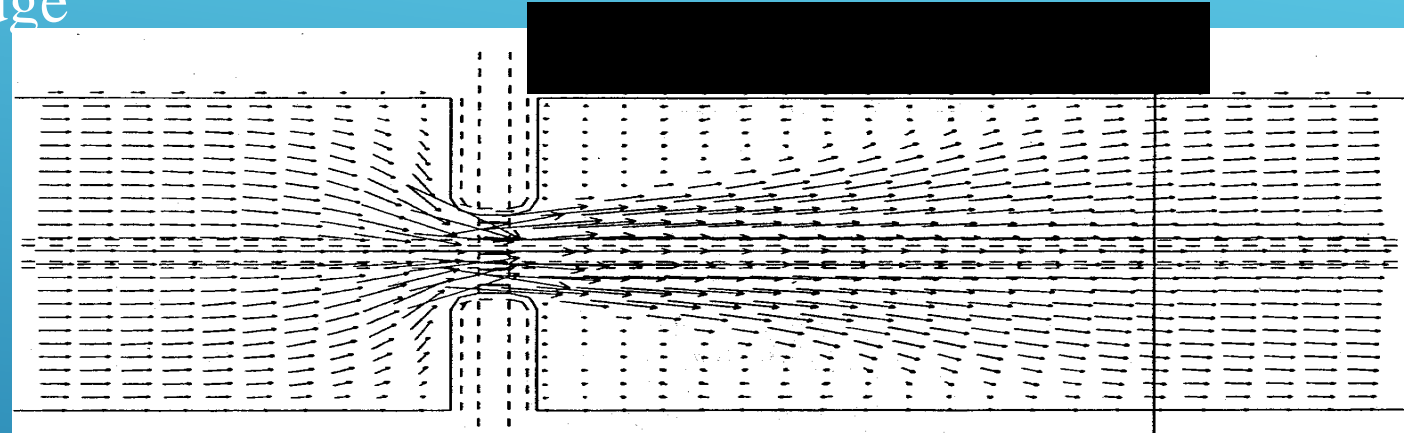

# 2 TYPES OF FLOW AT BRIDGES

- ▶ **Low Flow** - Flow where the water surface does not reach the low beam
- ▶ **High Flow** - Flow where the water surface reaches the deck or higher



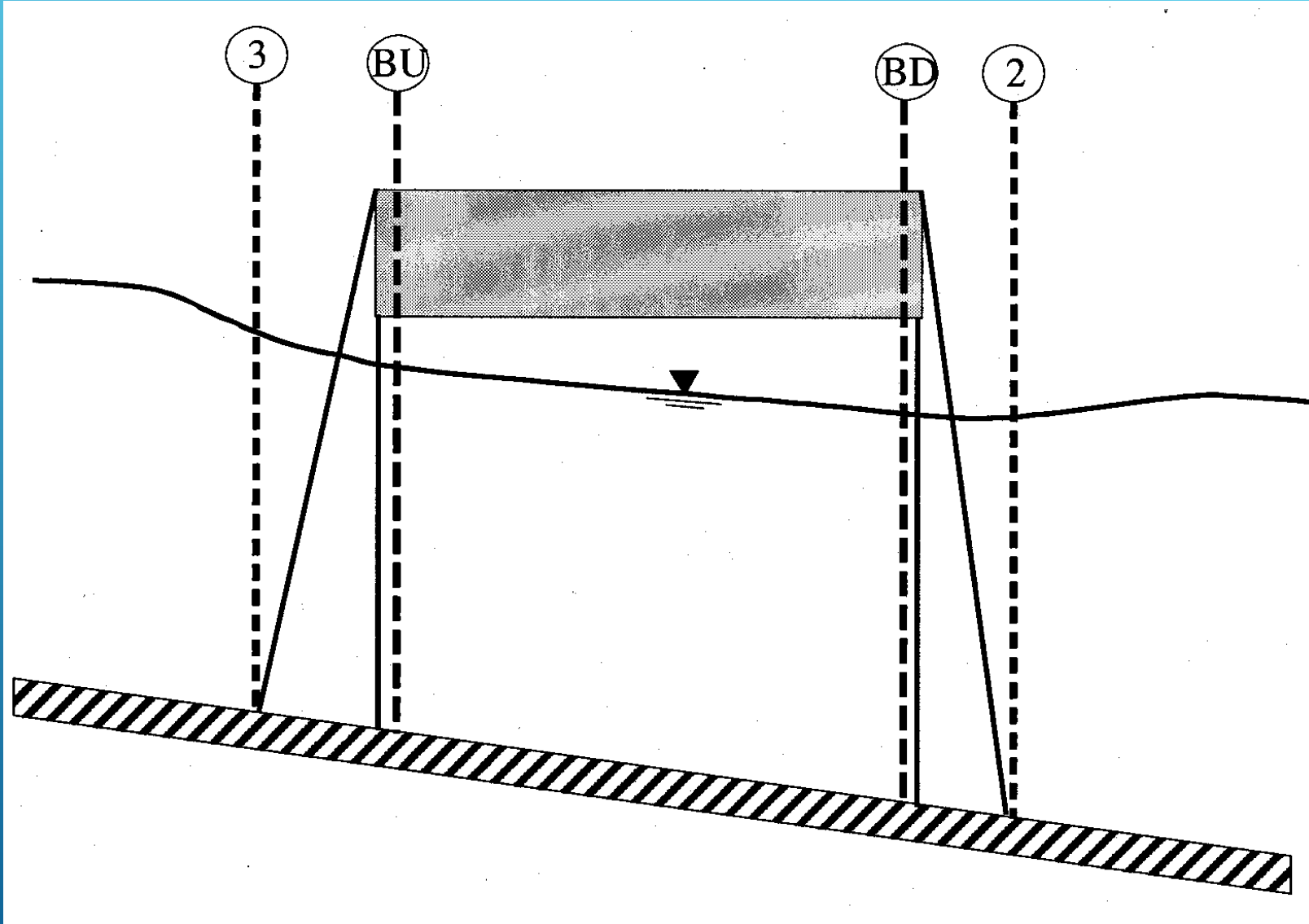

# LOW FLOW BRIDGE MODELING

## 3 TYPES OF FLOW

- ▶ **Class A Low Flow** - Subcritical Flow
  - ▶ Energy, Momentum, Yarnell, and WSPRO
- ▶ **Class B Low Flow** - Flow passes through critical depth
  - ▶ Energy and Momentum
- ▶ **Class C Low Flow** - Supercritical Flow
  - ▶ Energy and Momentum

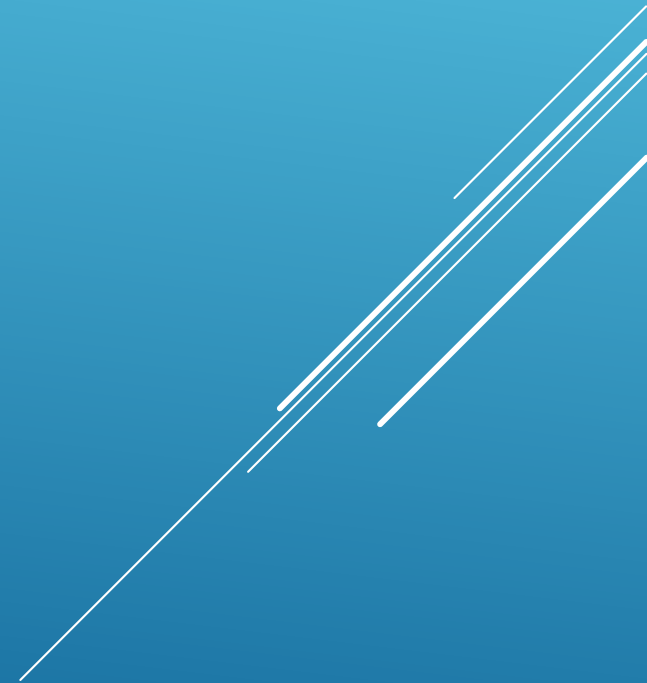

# LOW FLOW BRIDGE HYDRAULICS

## 4 METHODS OF MODELING

- ▶ Energy - physically based, accounts for friction losses and geometry changes through bridge, as well as losses due to flow transition & turbulence.
- ▶ Momentum - physically based, accounts for friction losses and geometry changes through bridge.
- ▶ FHWA WSPRO - energy based as well as some empirical attributes. Developed for bridges that constrict wide floodplains with heavily vegetated overbank areas.
- ▶ Yarnell - empirical formula developed to model effects of bridge piers.

# LOW FLOW BRIDGE MODELING

## CLASS A LOW FLOW - ENERGY METHOD

- ▶ Friction losses are computed as length times average friction slope.
- ▶ Energy losses are empirical coefficient times change in velocity head (expansion and contraction losses).
- ▶ Does not account for pier drag forces.



# LOW FLOW BRIDGE MODELING

## CLASS A LOW FLOW - MOMENTUM METHOD

- ▶ Friction losses are external skin friction = wetted perimeter times length times shear stress.
- ▶ Requires entering coefficient of drag for piers,  $C_D$

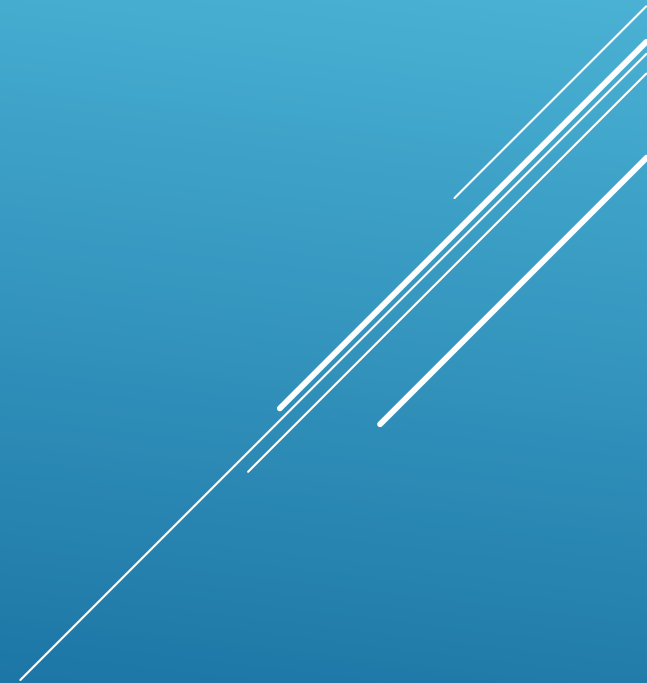

# LOW FLOW BRIDGE MODELING

## CLASS A LOW FLOW - YARNELL EQUATION

- ▶ Based on 2,600 lab experiments on different pier shapes
- ▶ Requires entering pier shape coefficient,  $K$
- ▶ Should only be used where majority of losses are due to piers.

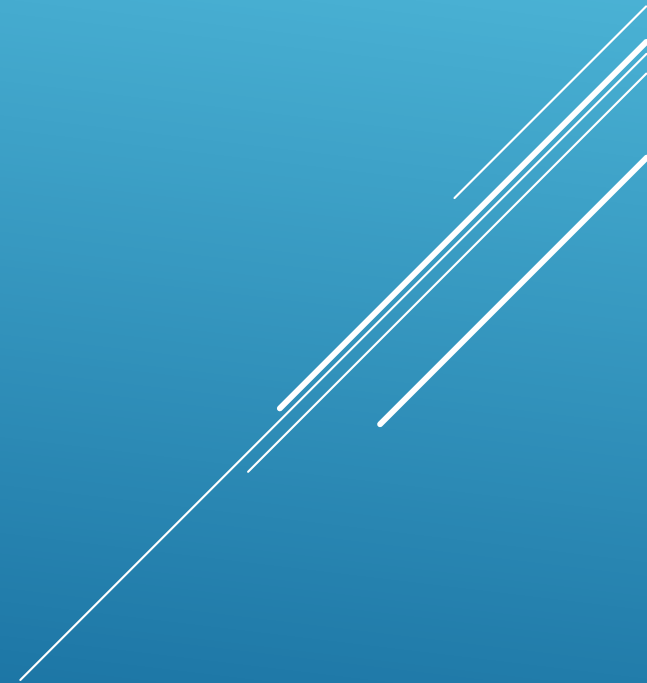

# LOW FLOW BRIDGE MODELING

## CLASS A LOW FLOW - WSPRO

- ▶ Federal Highway Administrations method of analyzing bridges
- ▶ Uses energy equation in an iterative procedure

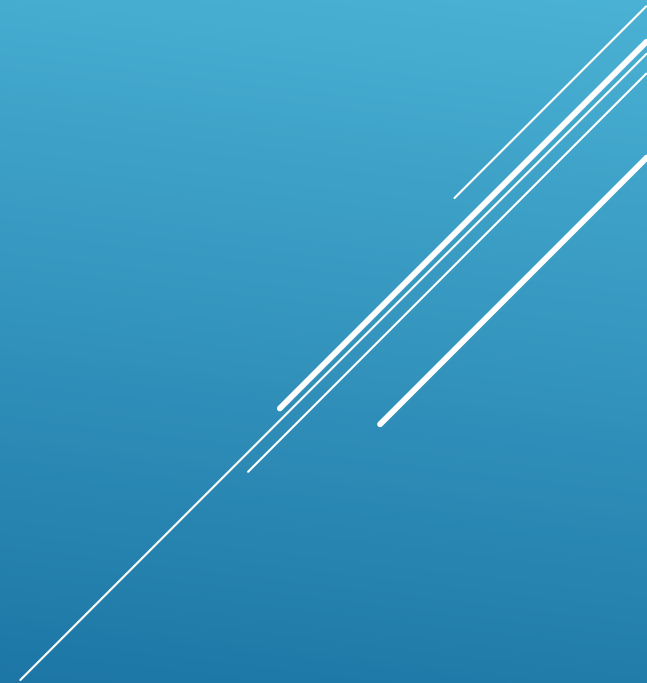

# CLASS B AND C LOW-FLOW METHODS

Two methods available:

- (1) Momentum** - With irregular cross-section data and rapidly changing water surface elevation, the estimate of bed slope can be erratic. Therefore, the weight component is automatically turned off for Class B flow.
- (2) Energy** - During Class B flow, a dramatic change in depth can occur with resulting large changes in velocity head. Contraction and Expansion energy losses may be overestimated with "traditional" contraction and expansion coefficients.

# LOW FLOW BRIDGE HYDRAULICS SUMMARY

- Bridge piers are small obstruction to flow, friction losses predominate - Energy, Momentum, or WSPRO
- Pier and friction losses predominate - Momentum
- Flow passes through critical depth in vicinity of bridge - Energy or Momentum
- Pier losses are dominant - Yarnell
- Supercritical flow without piers - Energy or Momentum
- Supercritical flow with piers - Momentum

# HIGH FLOW BRIDGE METHODS

**(1) Energy Method** - The area of the deck is subtracted and additional wetted perimeter is added. The water surface elevation represents the hydraulic grade line.

- ▶ This method does not account for the shape of the entrance or piers.
- ▶ Conveyance is calculated treating the bridge as a cross section, including flow over the roadway.

# HIGH FLOW BRIDGE METHODS

(2) **Pressure and Weir Method** - Treats the flow as two separate components.

- ▶ Flow through the opening is pressure flow.
  - ▶ Gate equation
  - ▶ Full pressure (Orifice) equation
- ▶ Weir equation for flow over the roadway, with submergence correction.
- ▶ HECRAS will automatically select the appropriate pressure flow equation.

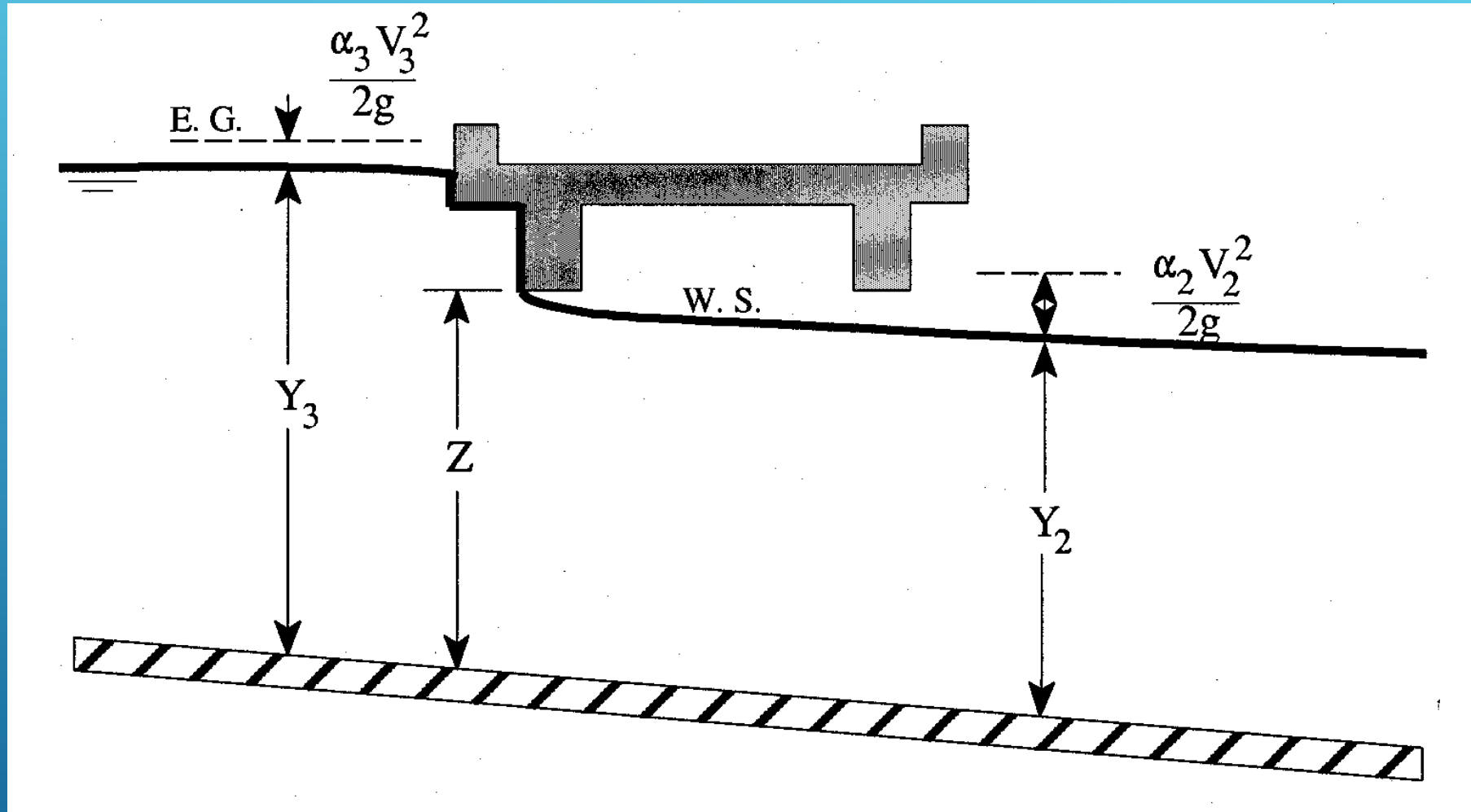

# HIGH FLOW - PRESSURE (SLUICE) FLOW

$$Q = C_d * A_{bu} \left[ Y_3 - \frac{Z}{2} + \frac{\alpha_3 V_3^2}{2g} \right]^{1/2}$$

$Q$  = Total discharge through the bridge opening

$C_d$  = Coefficient of discharge for pressure flow

$A_{bu}$  = Net area of the bridge opening at section BU

$Y_3$  = Hydraulic depth at section 3

$Z$  = Vertical distance from maximum bridge low chord to the mean river bed elevation at section BU

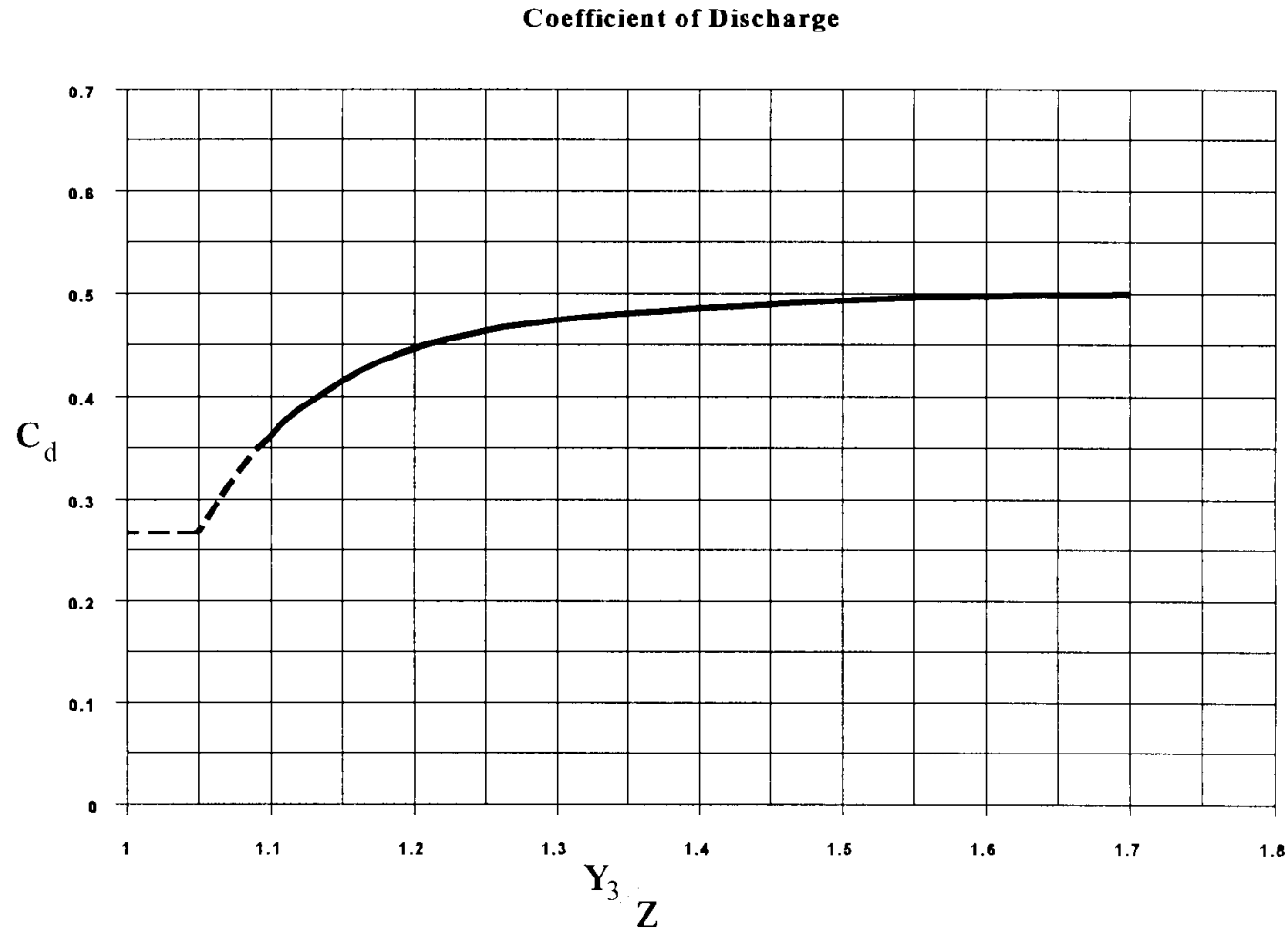

Figure 5.5 Coefficient of discharge for sluice gate type flow

# HIGH FLOW - PRESSURE (ORIFICE) FLOW

Used when both the upstream and downstream sides of the bridge is fully submerged

$$Q = C A \sqrt{2gH}$$

Q = Total discharge from full flowing orifice

C = Coeff. of discharge for fully submerged pressure flow

H = The difference between the energy gradient elevation upstream & the water surface elevation downstream

A = Net area of the bridge opening

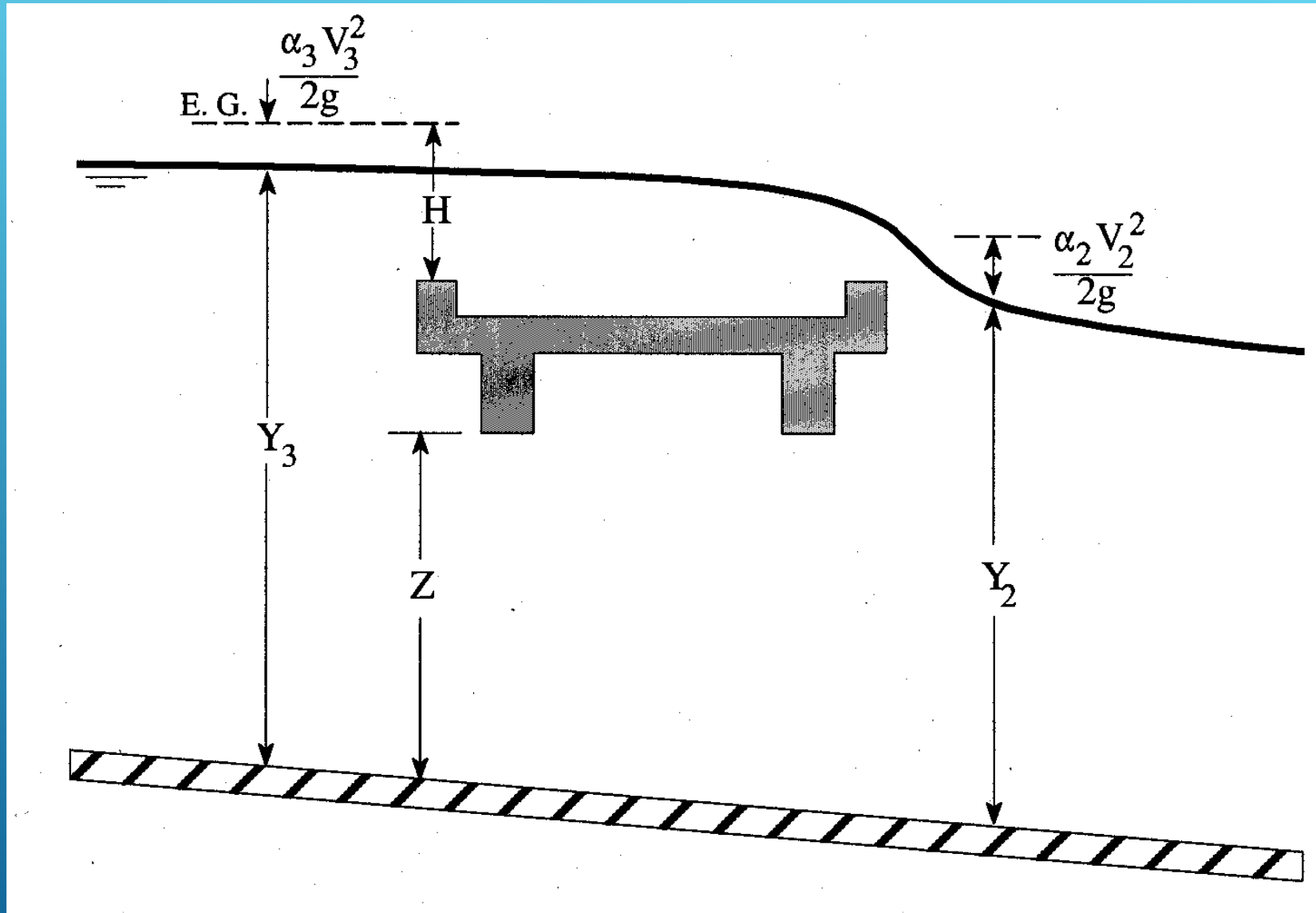

# HIGH FLOW - WEIR FLOW

$$Q = CLH^{3/2}$$

Q = Total flow over the weir

C = Coefficient of discharge for weir flow (~2.5 to 3.1 for free flow)

L = Effective length of the weir

H = Difference between energy elev. upstream and road crest



$$Q_{\text{submerged}} = Q_{\text{free}} \cdot \text{Reduction Factor}$$

$$\text{Submergence} = \frac{H_2}{H_1}$$

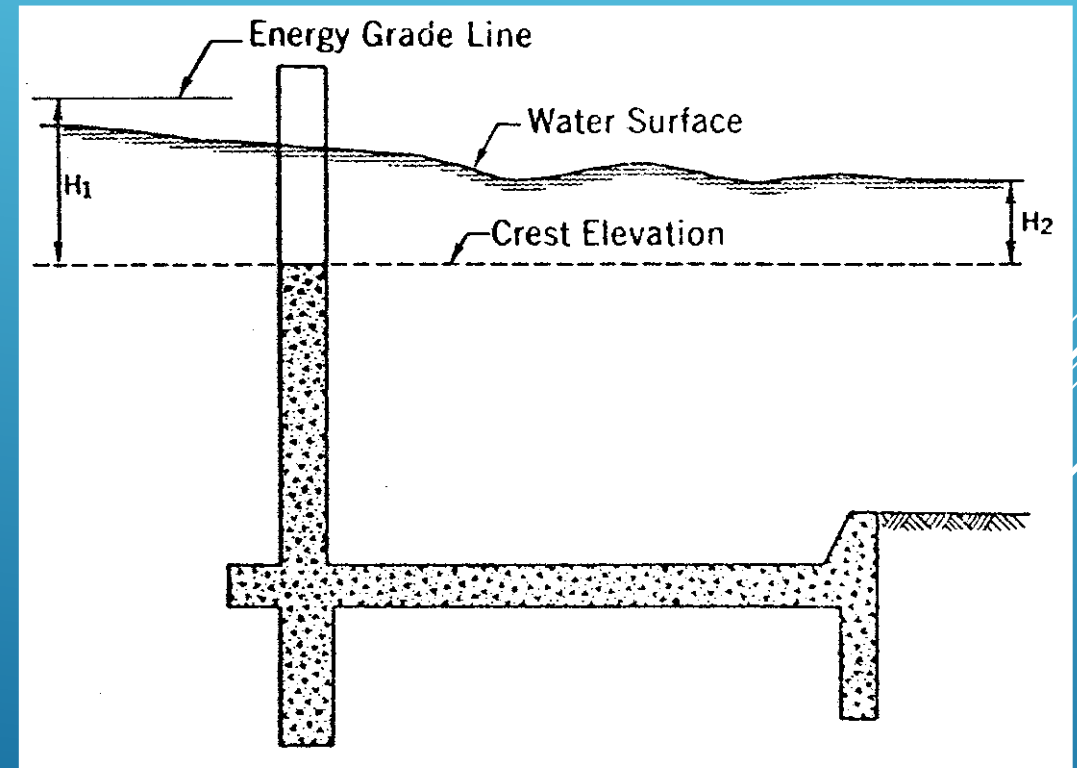

Discharge Reduction for Submerged Flow

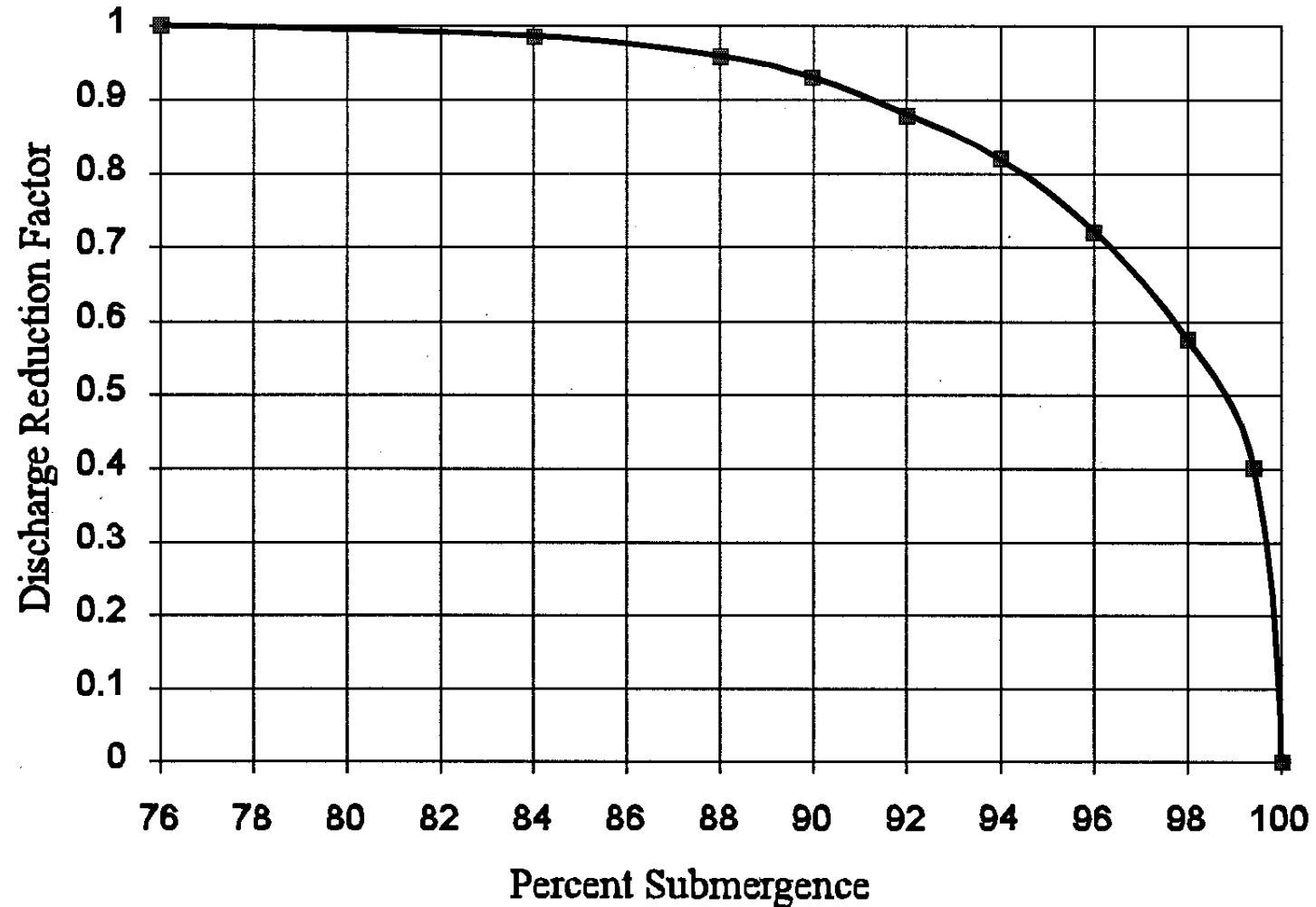

# HIGH FLOW BRIDGE MODELING SUMMARY

- ▶ When bridge deck is a small obstruction to the flow and not acting like a pressurized orifice, use energy method.
- ▶ When overtopped and tailwater is not submerging flow, use pressure/weir method.
- ▶ When overtopped and highly submerged, use energy method.



# ADDING THE BRIDGE



# LOCATING CROSS-SECTIONS NEAR BRIDGES

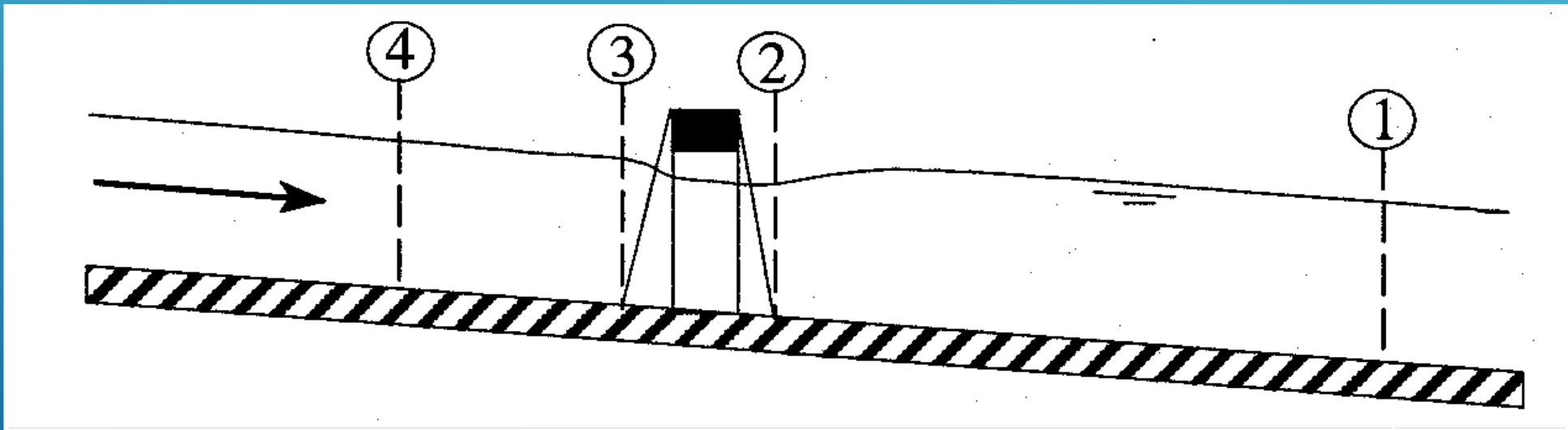

# LOCATING CROSS-SECTIONS NEAR BRIDGES

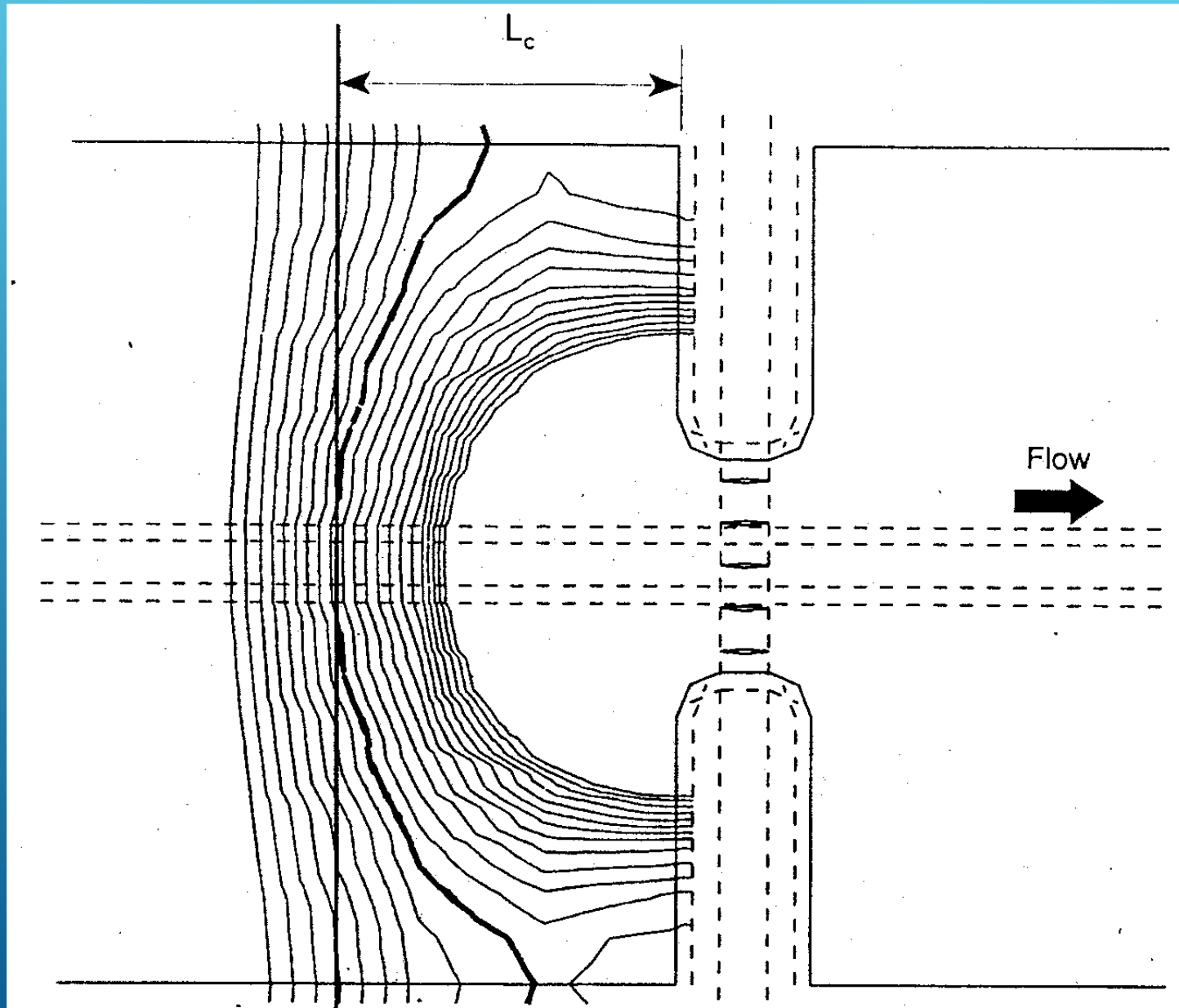

# LOCATING CROSS-SECTIONS NEAR BRIDGES

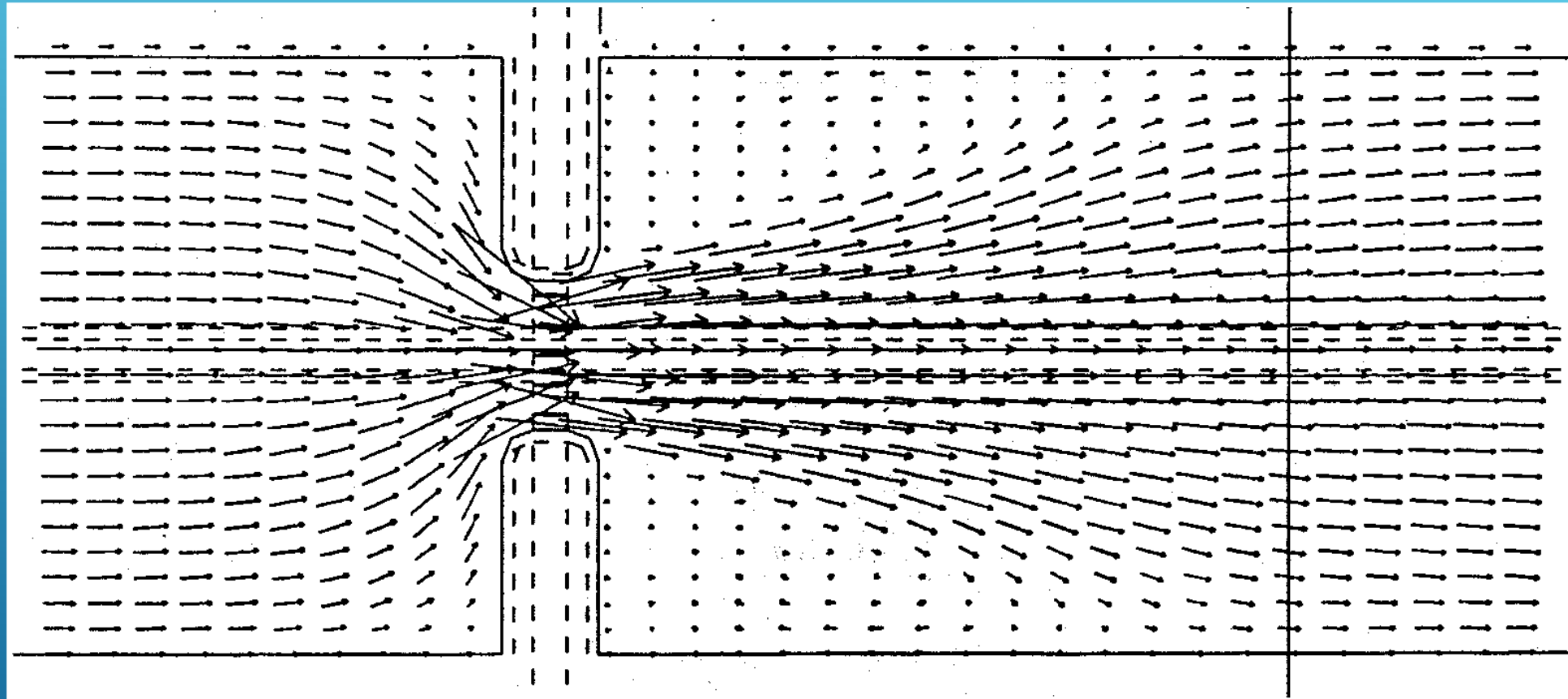

Fully Effective Flow

Contraction

Thru Bridge

Expansion

Fully Expanded Flow

## LOCATING CROSS-SECTIONS NEAR BRIDGES

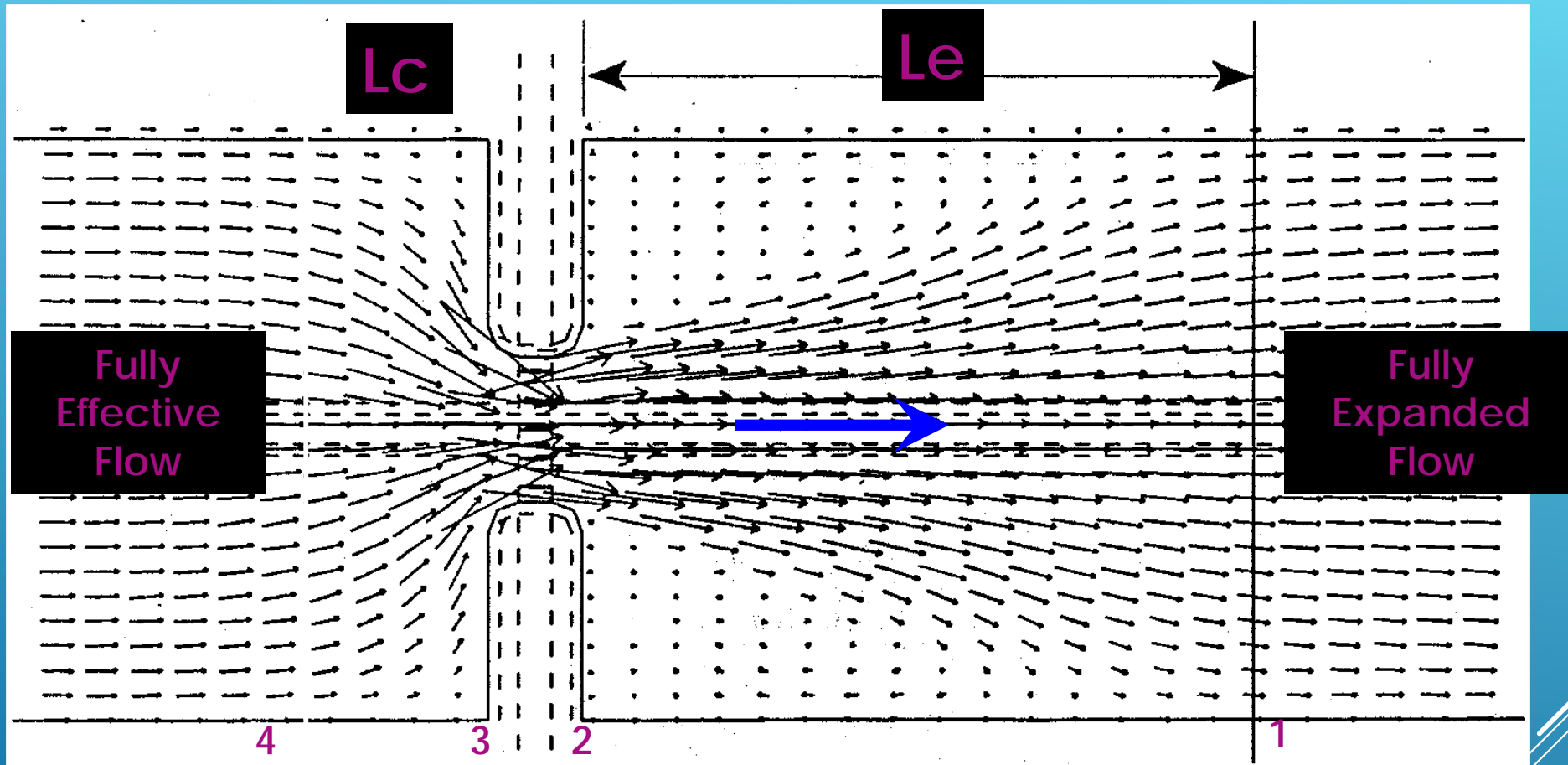

$L_c$  and  $L_e$  can be determined by field investigation during high flow or can be computed.

# LOCATING CROSS-SECTIONS NEAR BRIDGES

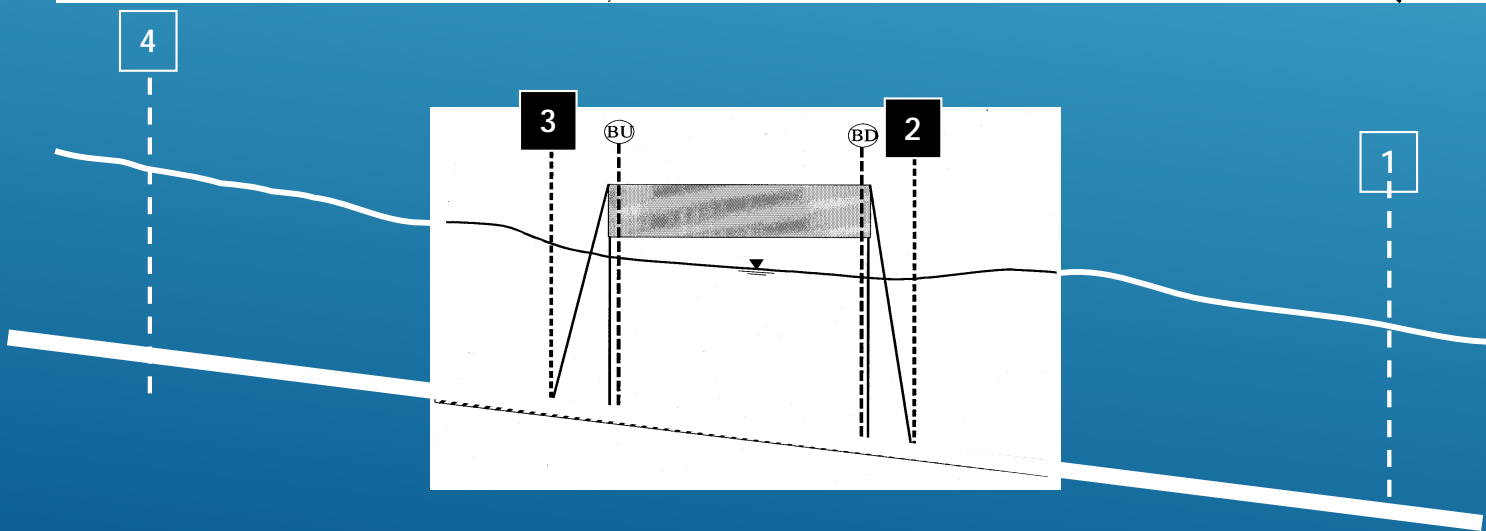
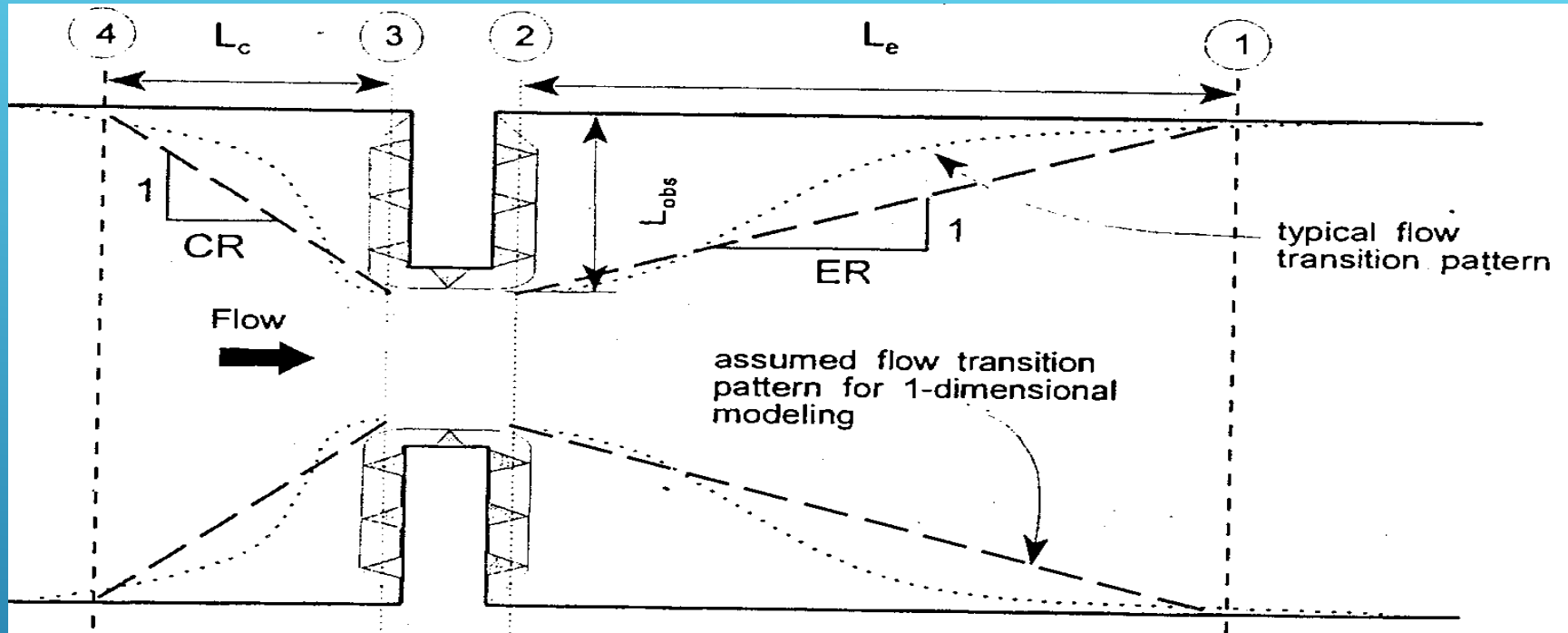

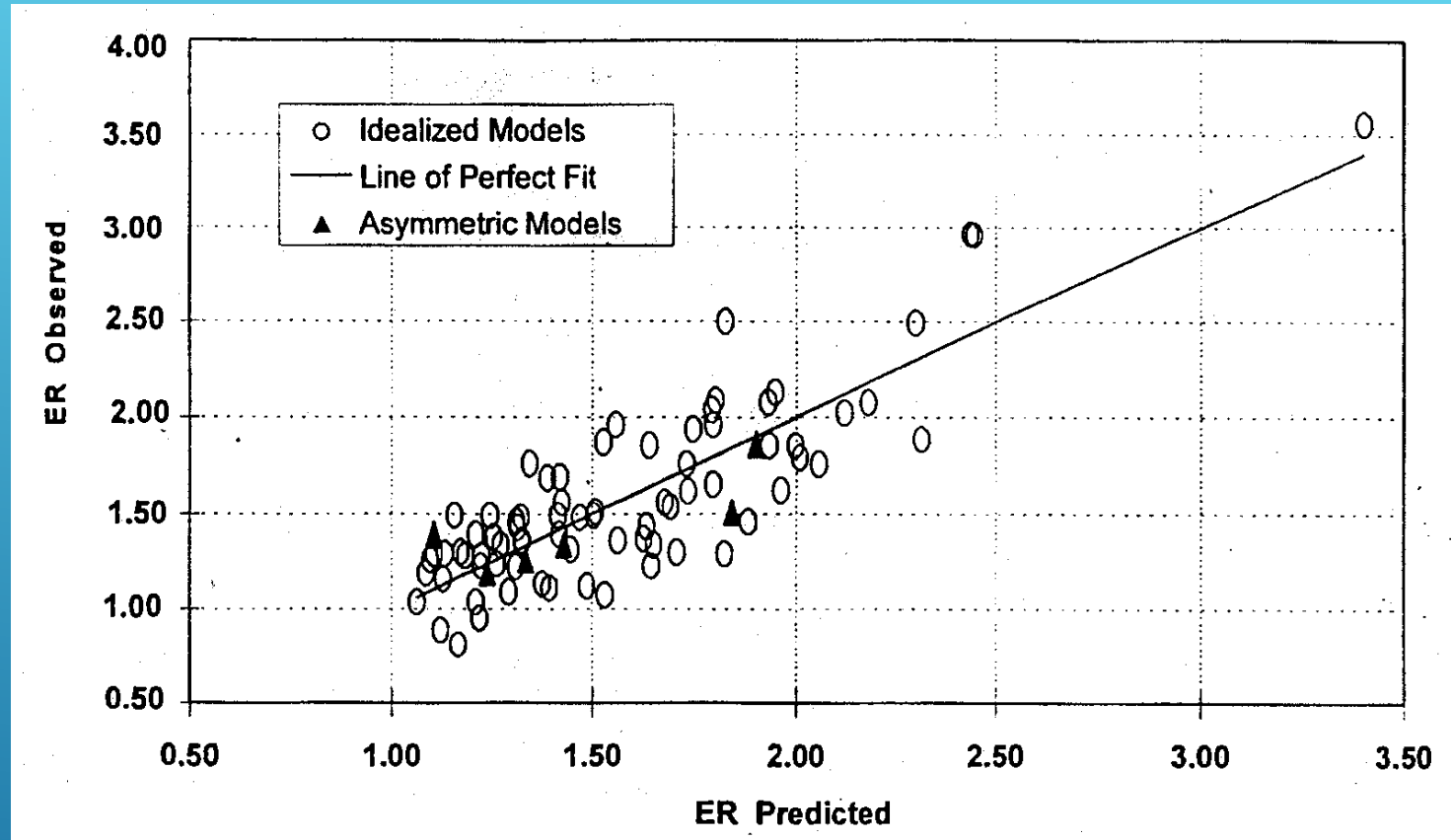

$$ER = 0.421 + 0.485 \left( \frac{F_{c2}}{F_{c1}} \right) + 1.8 \times 10^{-5} (Q)$$

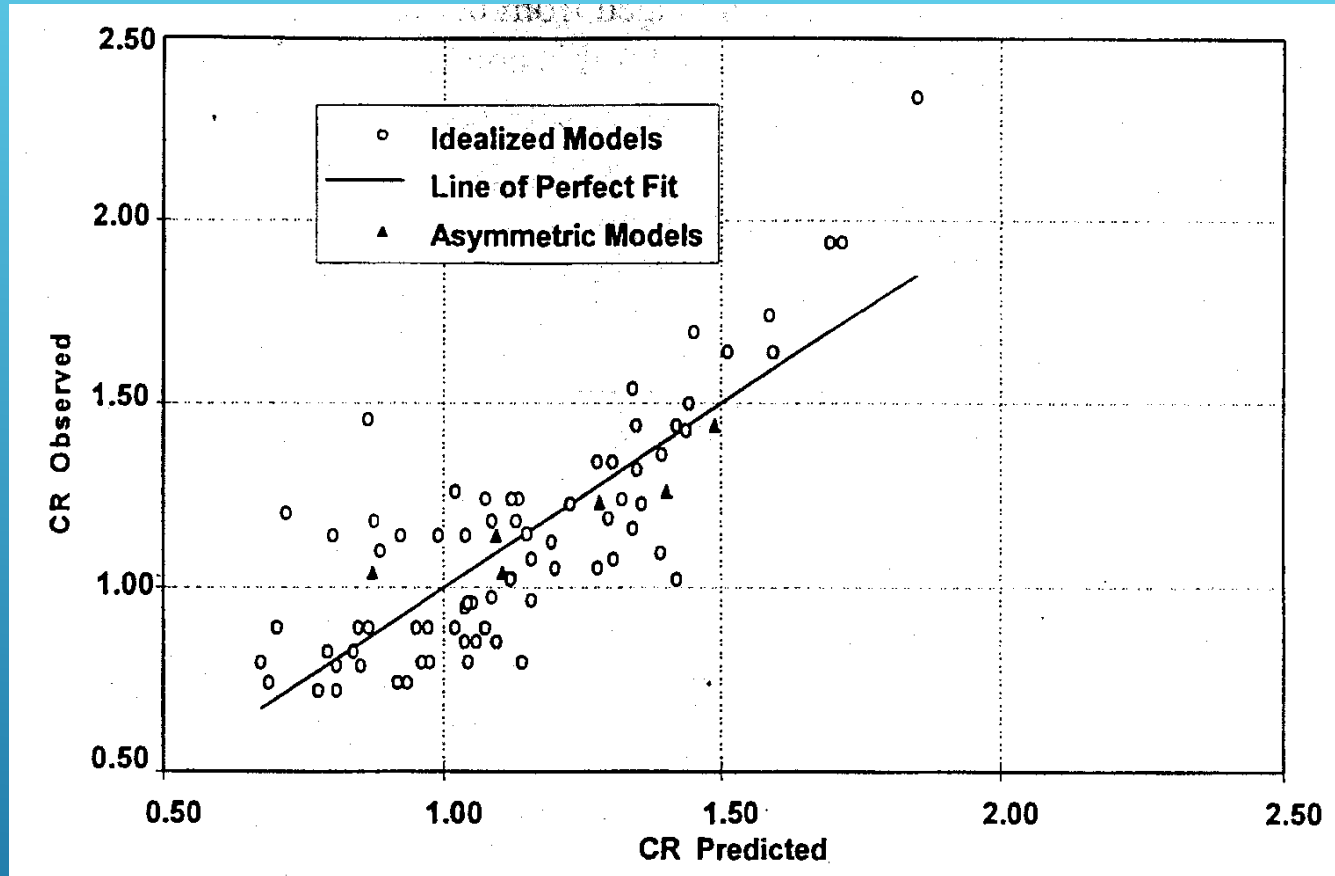

$$CR = 1.4 - 0.333 \left( \frac{F_{c2}}{F_{c1}} \right) + 1.86 \left( \frac{Q_{ob}}{Q} \right)^2 - 0.19 \left( \frac{n_{ob}}{n_c} \right)^{0.5}$$

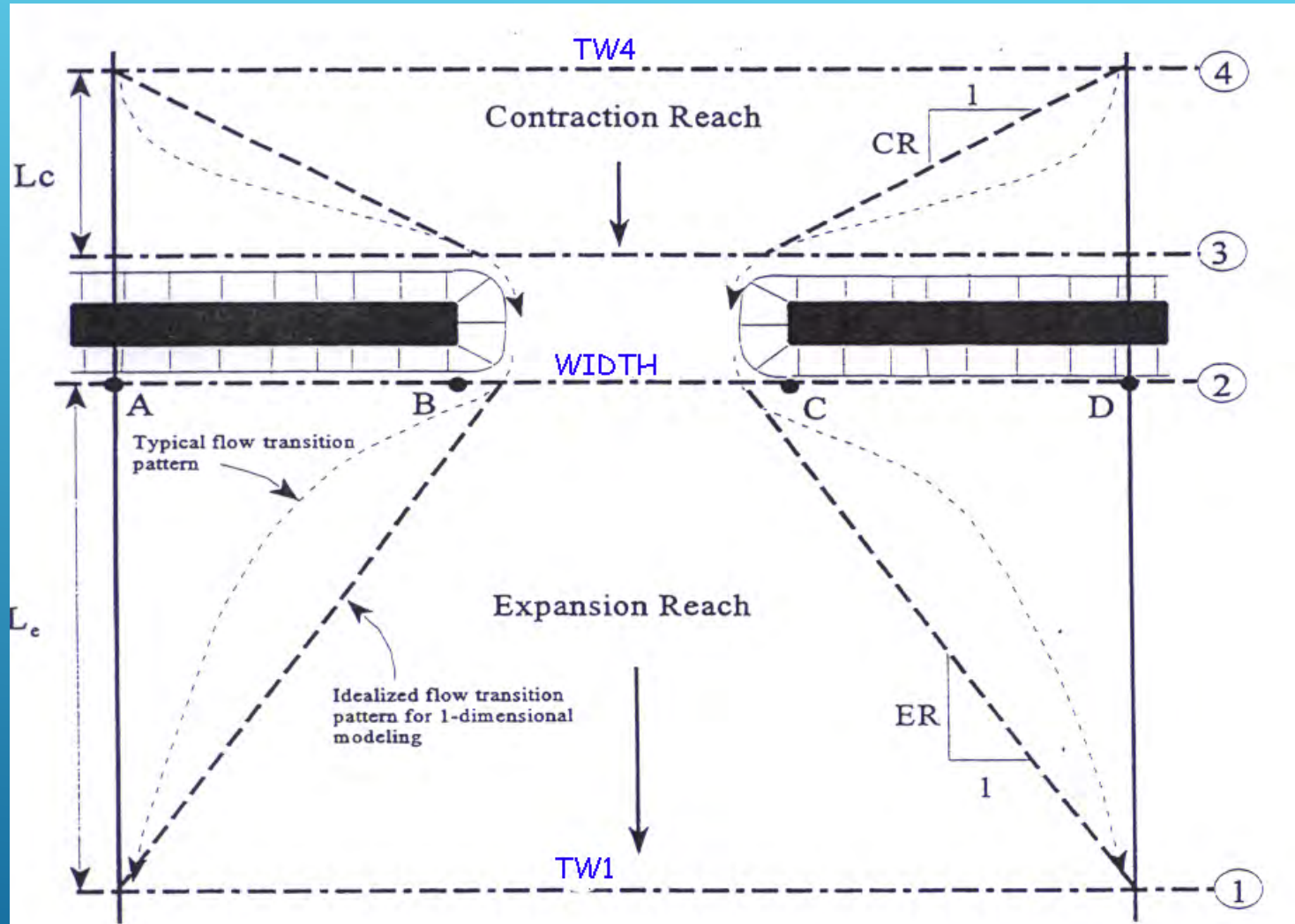

$$L_e = ER * (TW1 - WIDTH) / 2$$

$$L_c = CR * (TW4 - WIDTH) / 2$$

Rule of thumb: ER = 2  
CR = 1

# EXAMPLE COMPUTATION OF LE AND LC

Given: Fully expanded flow top width at Cross Section 1 = 300 feet

Fully expanded flow top width at Cross Section 4 = 250 feet

Distance from Point B to Point C (bridge opening width) = 40 feet

Find: Recommended locations of Cross Sections 1 and 4

$$L_e = 2 * (300 - 40) / 2 = \underline{260 \text{ feet downstream of bridge}}$$

$$L_c = 1 * (250 - 40) / 2 = \underline{105 \text{ feet upstream of bridge}}$$

This assumes ER=2 and CR=1

# EXPANSION & CONTRACTION COEFFICIENTS

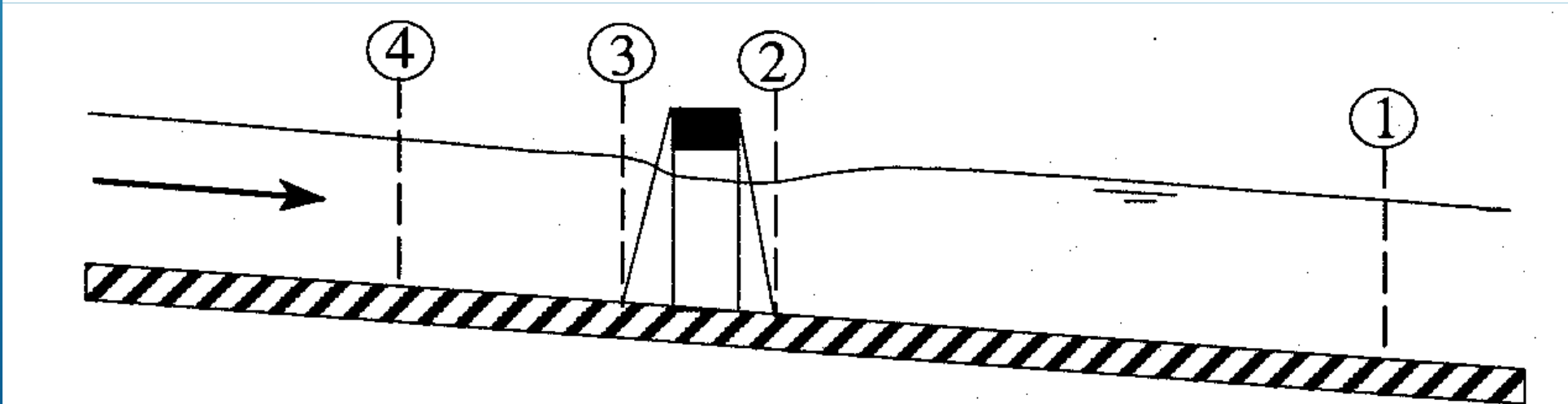
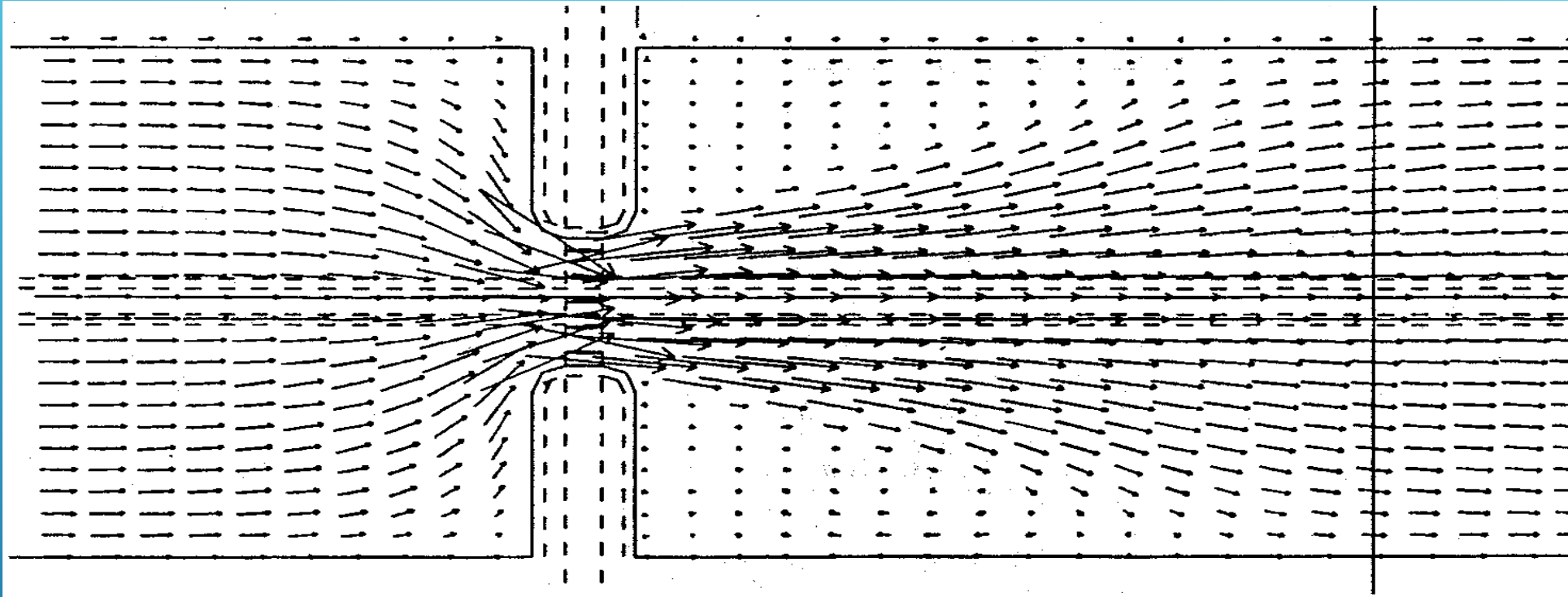

# EXPANSION & CONTRACTION COEFFICIENTS

	Contraction	Expansion
No Transition	0	0
Gradual Transition	0.1	0.3
<b>Typical Bridge Transition</b>	<b>0.3</b>	<b>0.5</b>
Abrupt Transition	0.6	0.8

# INEFFECTIVE FLOW AREAS

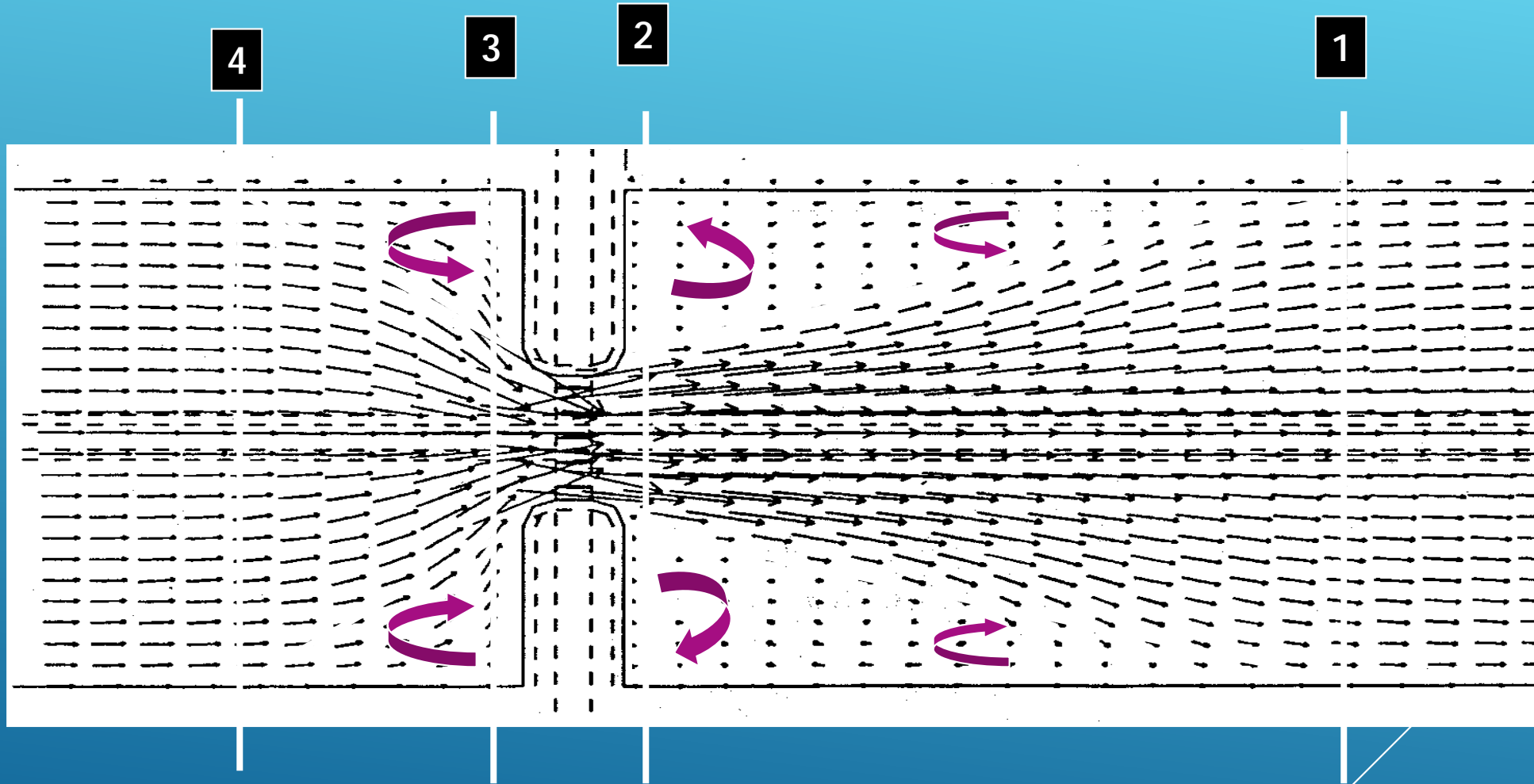

# INEFFECTIVE FLOWS

The ineffective area option is used at bridge sections 2&3 to keep all the active flow in the area of the bridge opening until the elevations associated with the left and/or right ineffective flow areas are exceeded by the computed water surface elevation.

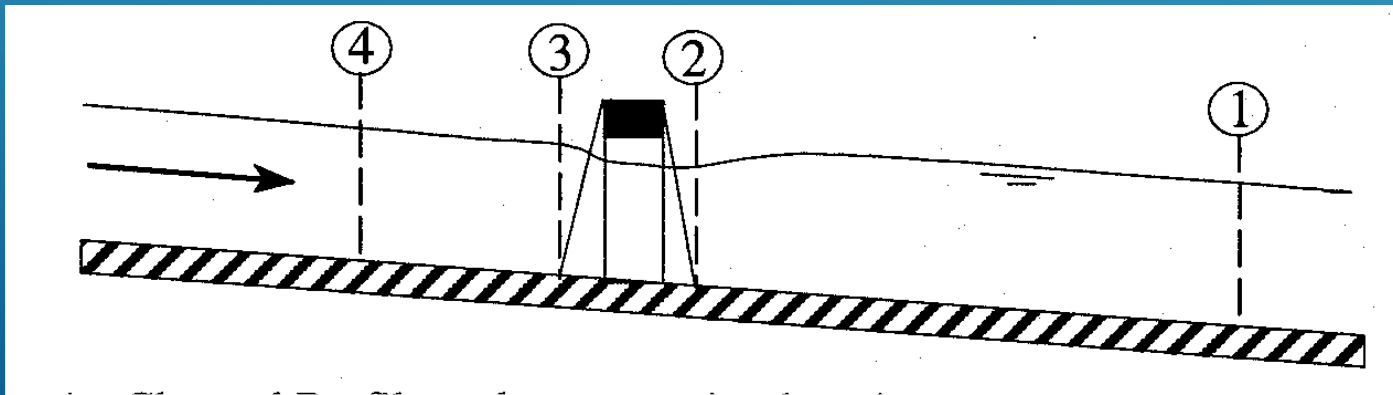
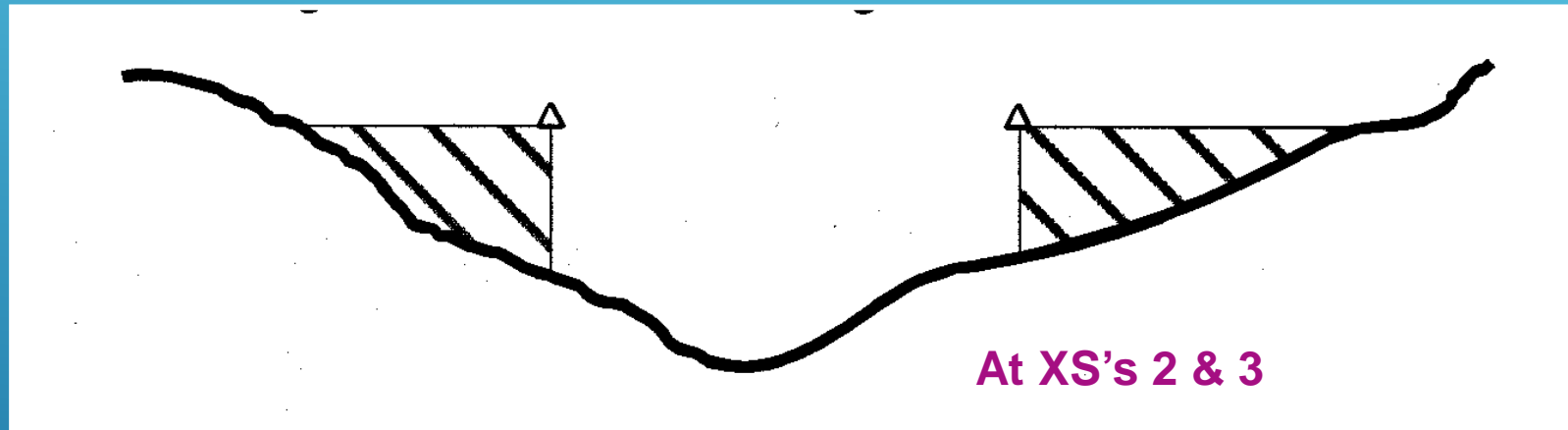

# ADDING THE BRIDGE

Select the Brdg/Culv button from the geometry data window:

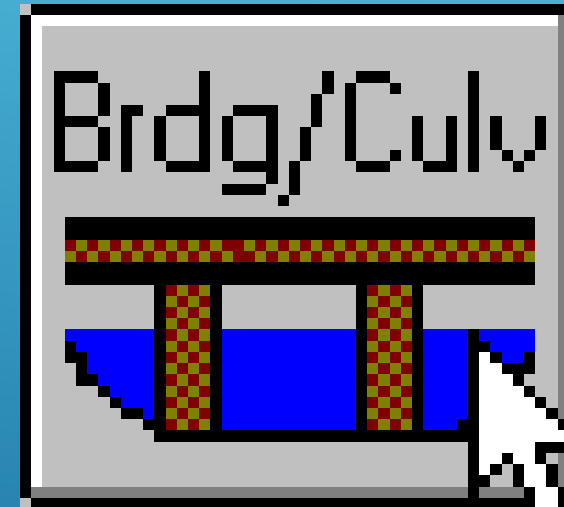
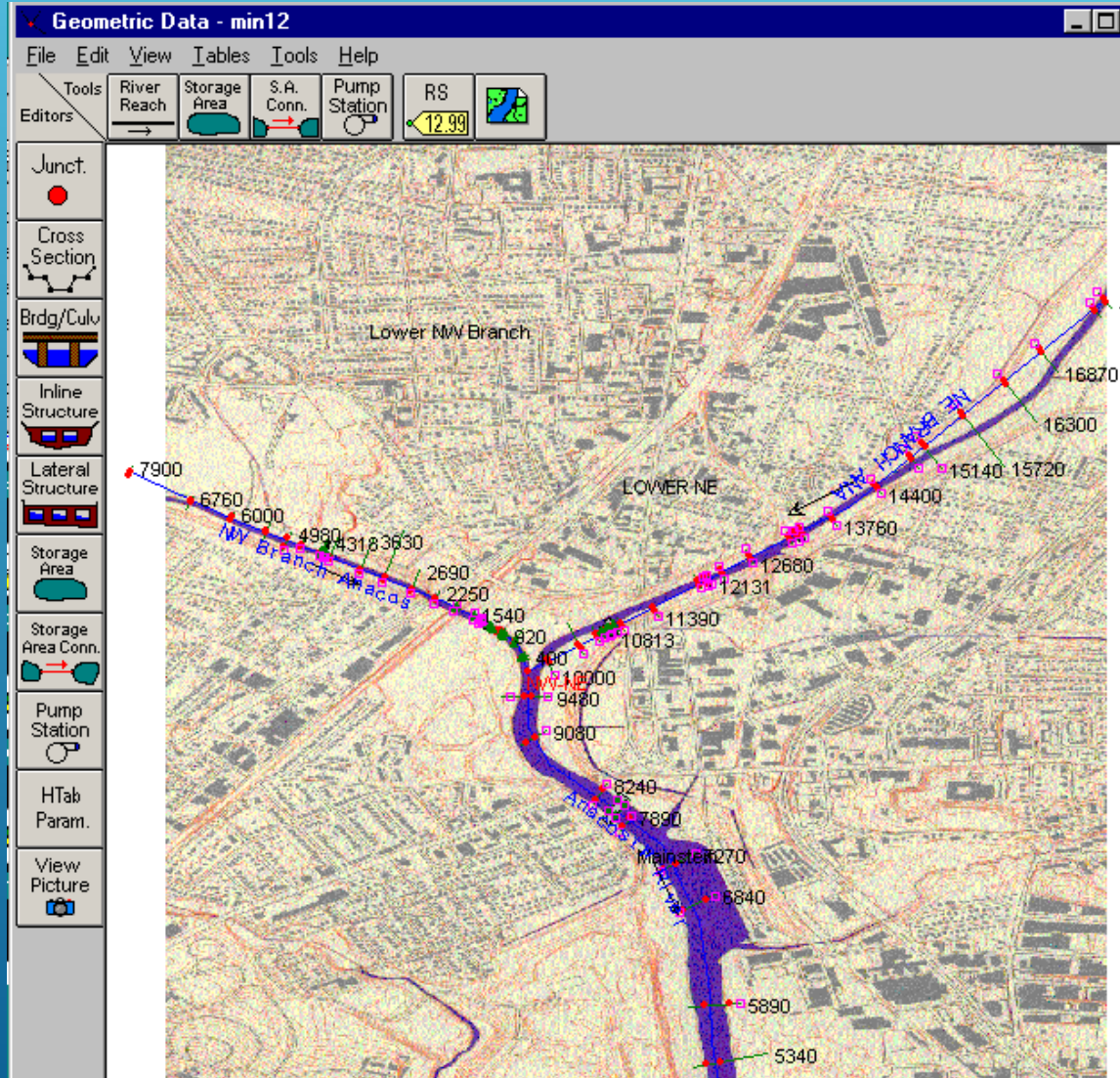

# ADDING THE BRIDGE

This brings up the Bridge Culvert Data window:

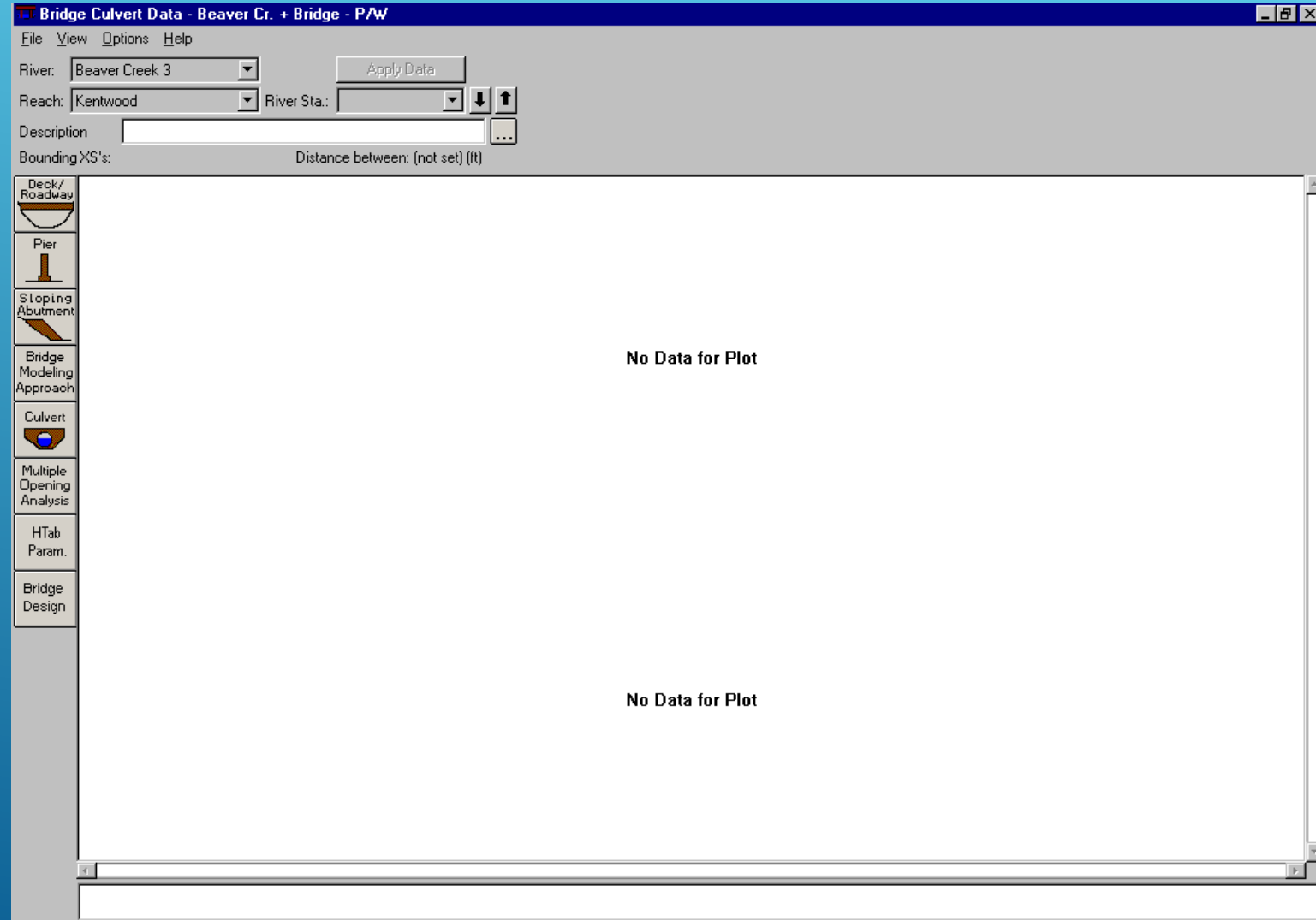

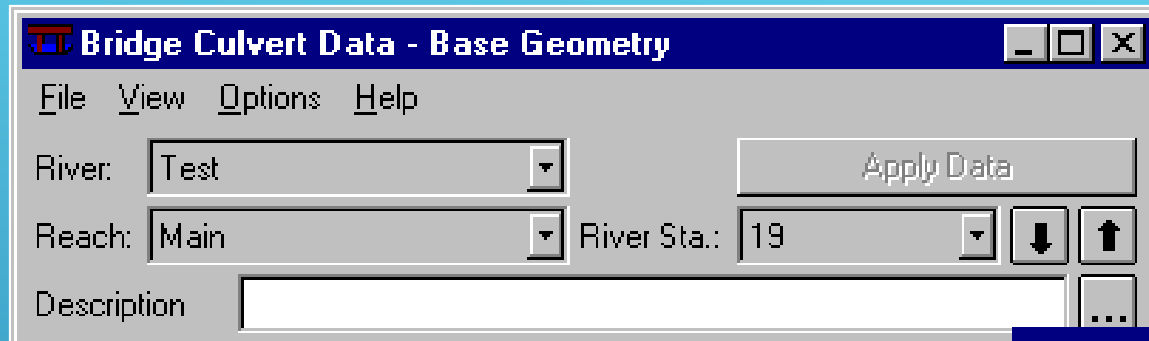

There are several other options in the options menu from the bridge data window ...

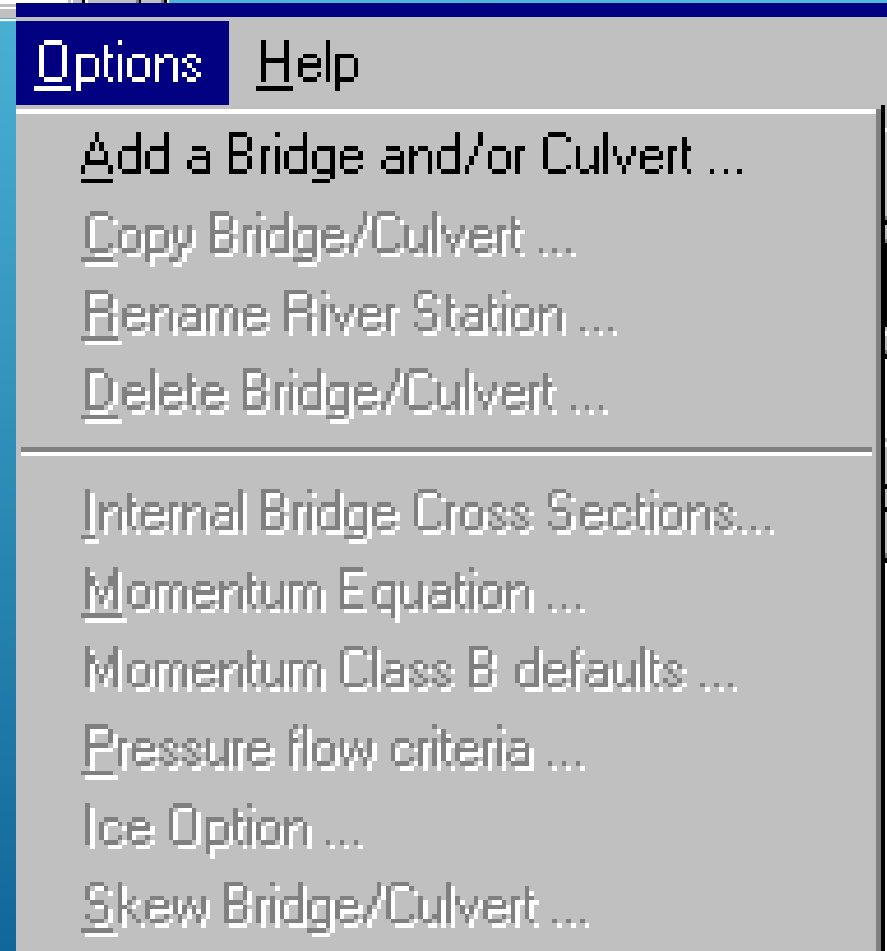

From the options menu, select “Add a Bridge and/or Culvert”:

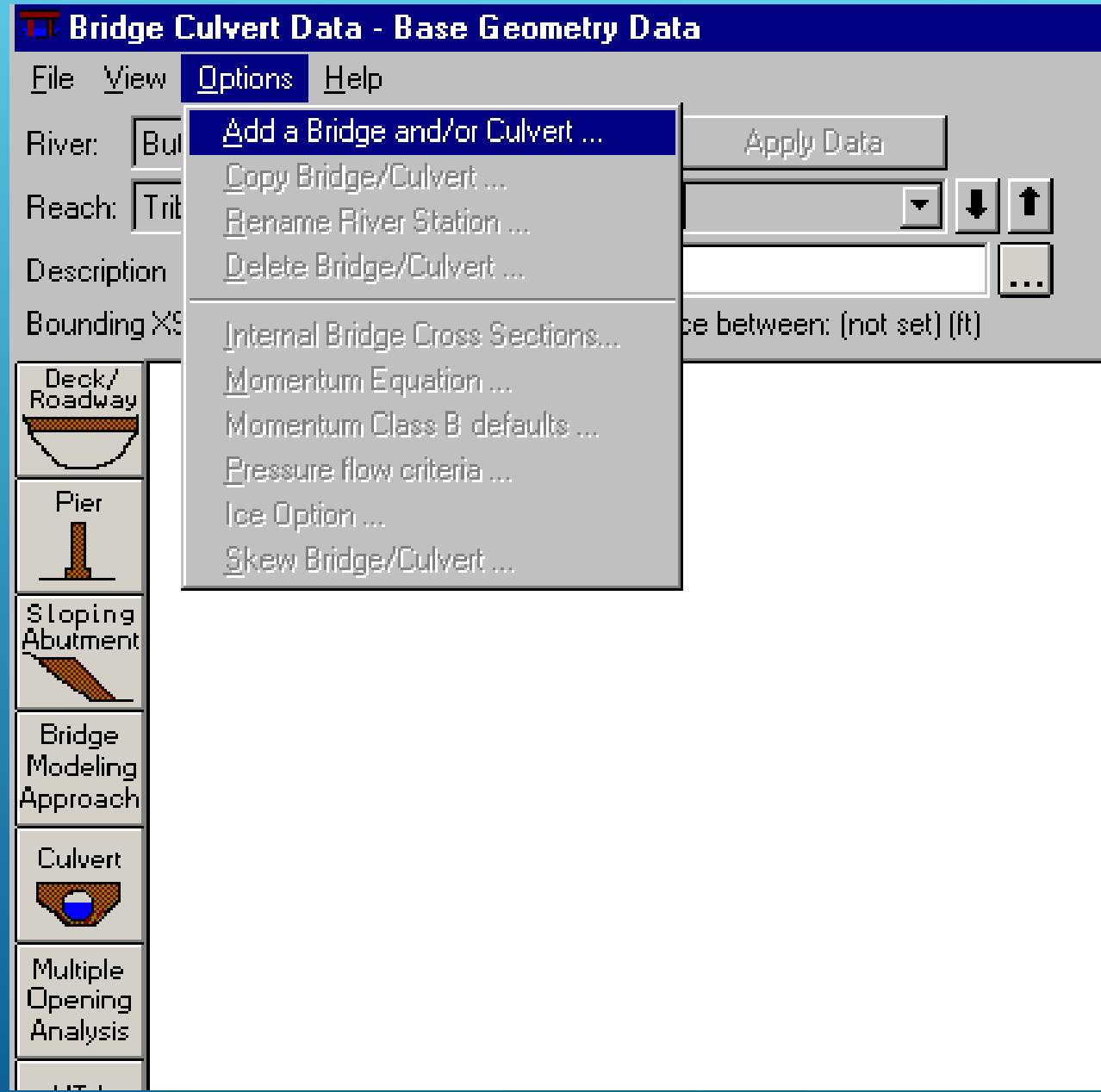

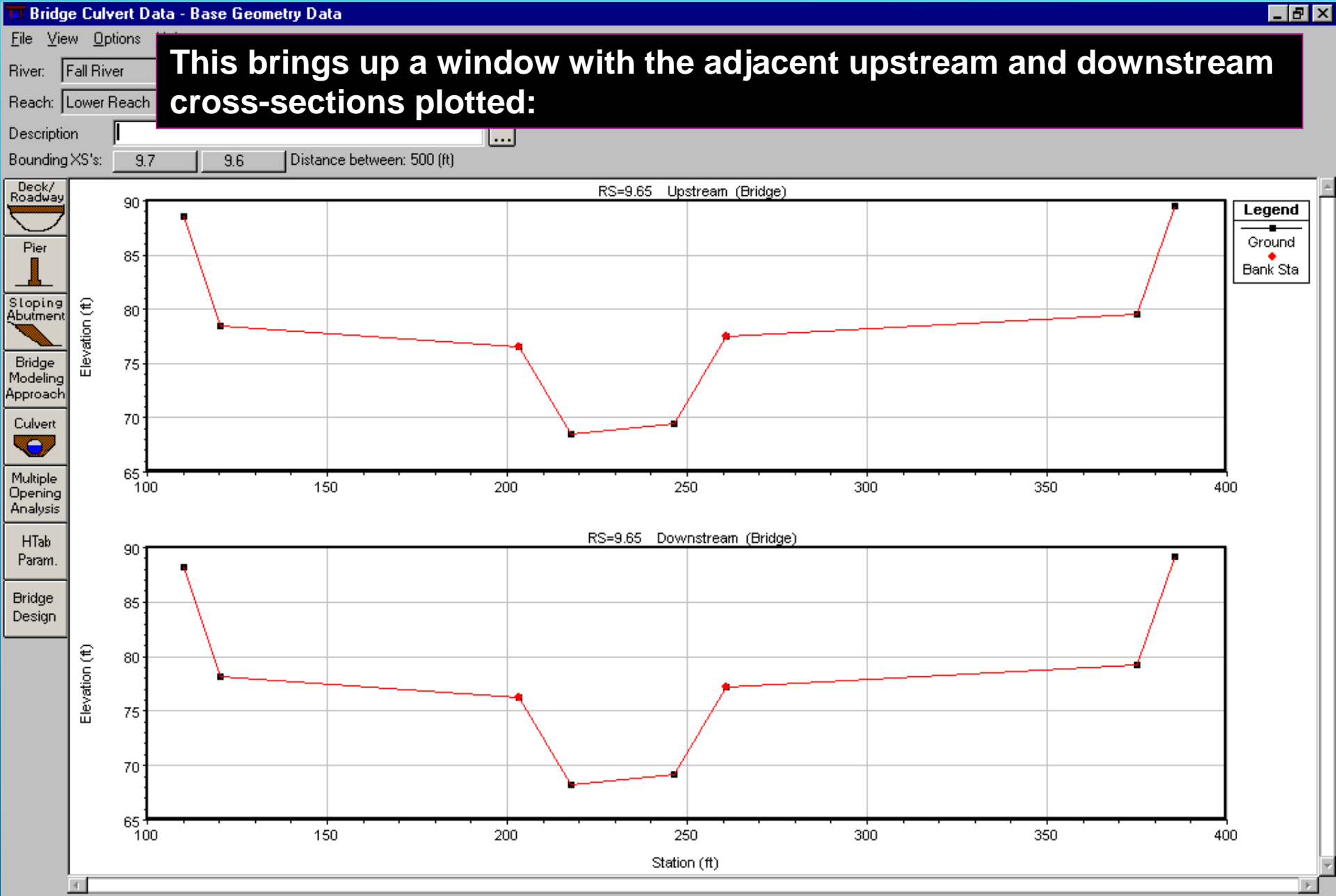

# DECK/ROADWAY

Next, select the Deck/Roadway button from the Bridge data window:

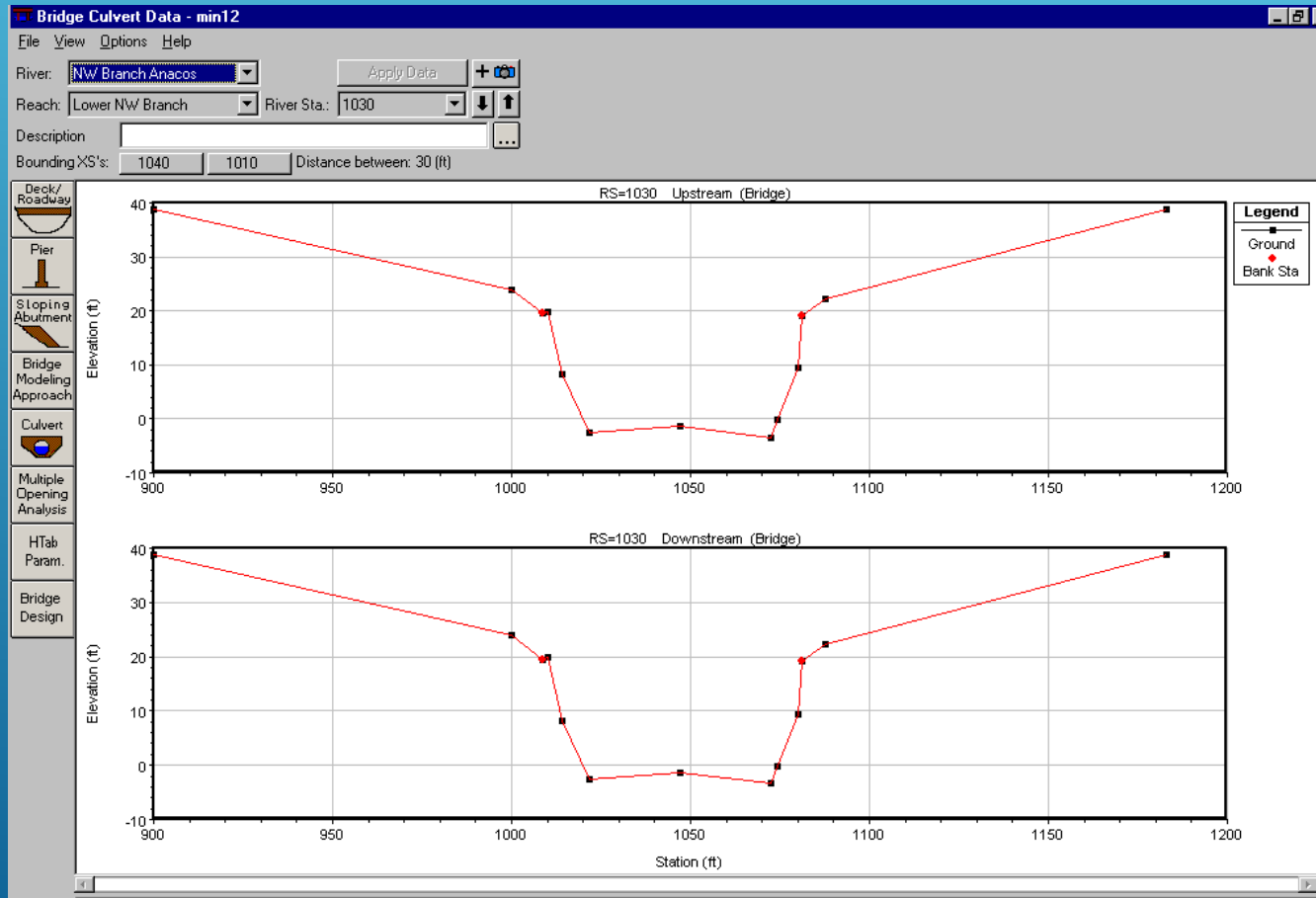

Notice the weir coefficient and max submergence window are showing the default values:

### Deck/Roadway Data Editor

Del Row					
Ins Row			2.6		

Upstream				Downstream			
	Station	high chord	low chord	Station	high chord	low chord	▲
1							▲
2							▲
3							▲
4							▲
5							▲
6							▲
7							▲
8							▼

U.S Embankment SS  D.S Embankment SS

**Weir Data**

Max Submergence:  Min Weir Flow El:

**Weir Crest Shape**

Broad Crested  
 Ogee

Enter distance between upstream cross section and deck/roadway. (ft)

Enter the data for the required values. Note that the U.S. and D.S. sideslopes are for cosmetic purposes only\*

**Deck/Roadway Data Editor**

Del Row		Distance	Width	Weir Coef
Ins Row		26	31	2.6

Upstream				Downstream		
	Station	high chord	low chord	Station	high chord	low chord
1	0.	341.	0.			
2	2444.	341.	0.			
3	2444.	341.	340.2			
4	2864.	341.	340.2			
5	2864.	341.	0.			
6	5500.	341.	0.			
7						
8						

U.S Embankment SS  D.S Embankment SS

Weir Data  
 Max Submergence:  Min Weir Flow El:

Weir Crest Shape  
 Broad Crested  
 Ogee

OK Cancel Clear Copy Up to Down

\*unless using the WSPRO method for low flow

Use the “Copy Up to Down” button to repeat the station-high chord-low chord data from the upstream to the downstream side, if applicable:

**Deck/Roadway Data Editor**

Del Row	Distance	Width	Weir Coef
Ins Row	26	31	2.6

Upstream				Downstream		
	Station	high chord	low chord	Station	high chord	low chord
1	0.	341.	0.	0.	341.	0.
2	2444.	341.	0.	2444.	341.	0.
3	2444.	341.	340.2	2444.	341.	340.2
4	2864.	341.	340.2	2864.	341.	340.2
5	2864.	341.	0.	2864.	341.	0.
6	5500.	341.	0.	5500.	341.	0.
7						
8						

U.S Embankment SS:  D.S Embankment SS:

Weir Data  
Max. Submergence:  Min Weir Flow El:

Weir Crest Shape  
 Broad Crested  
 Ogee

OK Cancel Clear **Copy Up to Down**

After selecting OK from the bridge deck window, it replots the U.S. and D.S. x-sections showing the bridge deck:

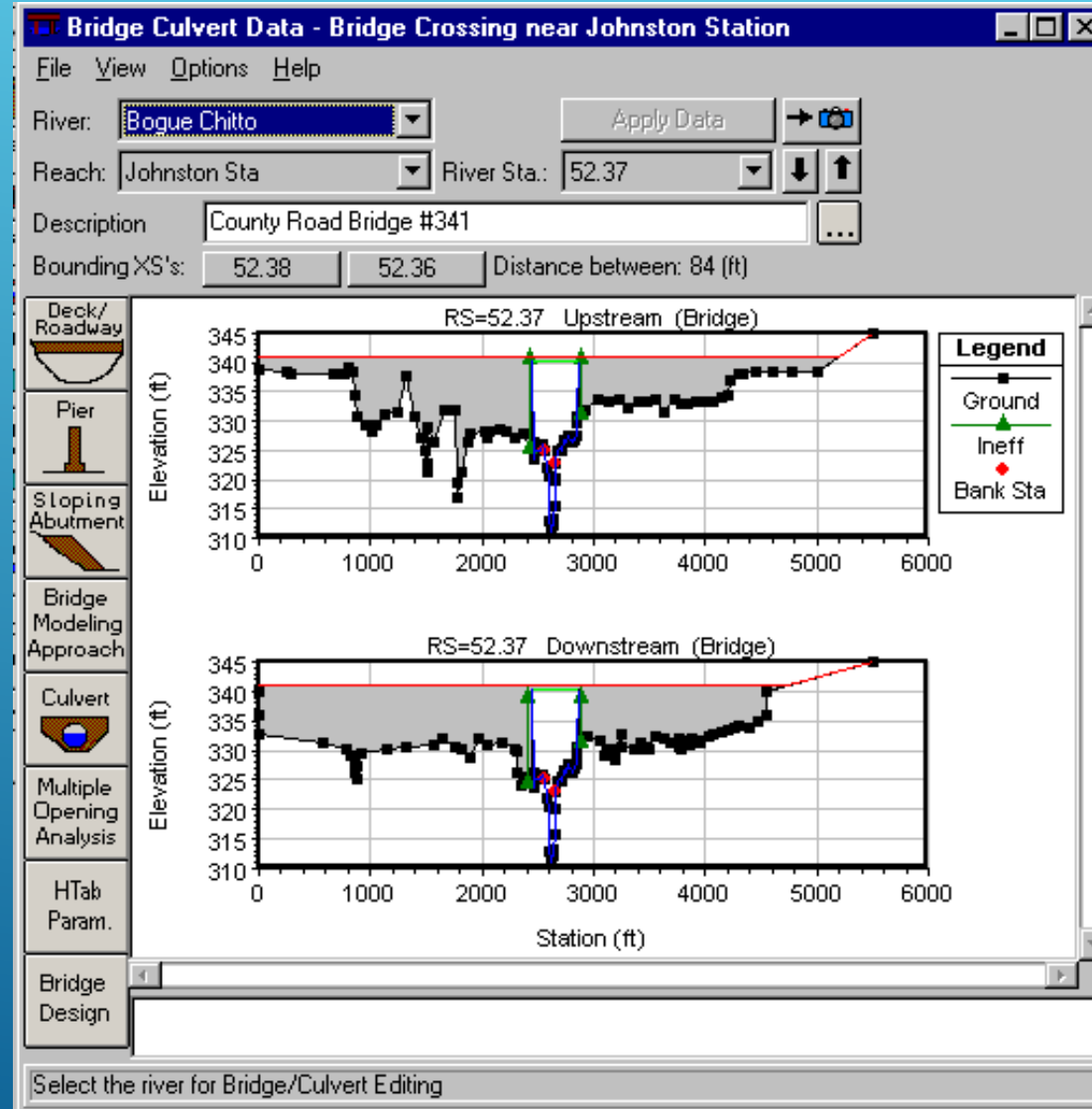

# PIERS

Piers can be added by selecting the Pier button from the bridge data window:

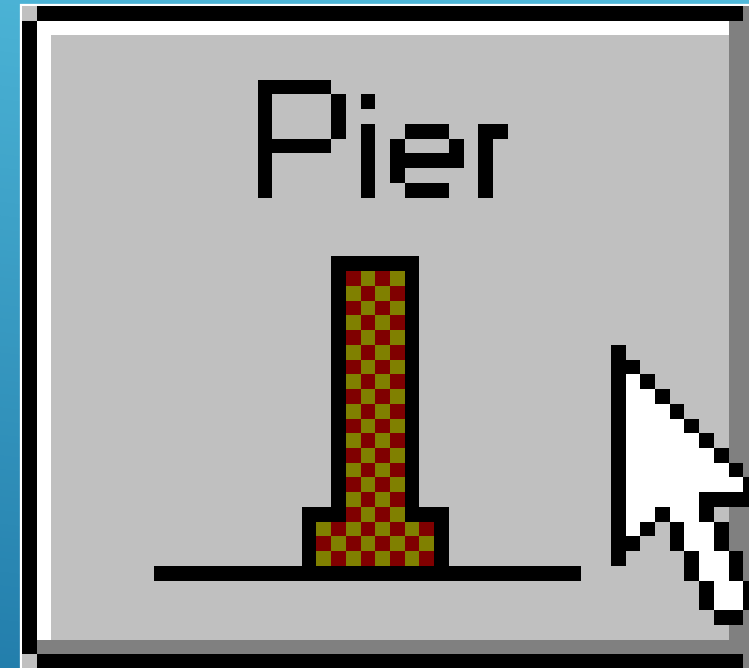
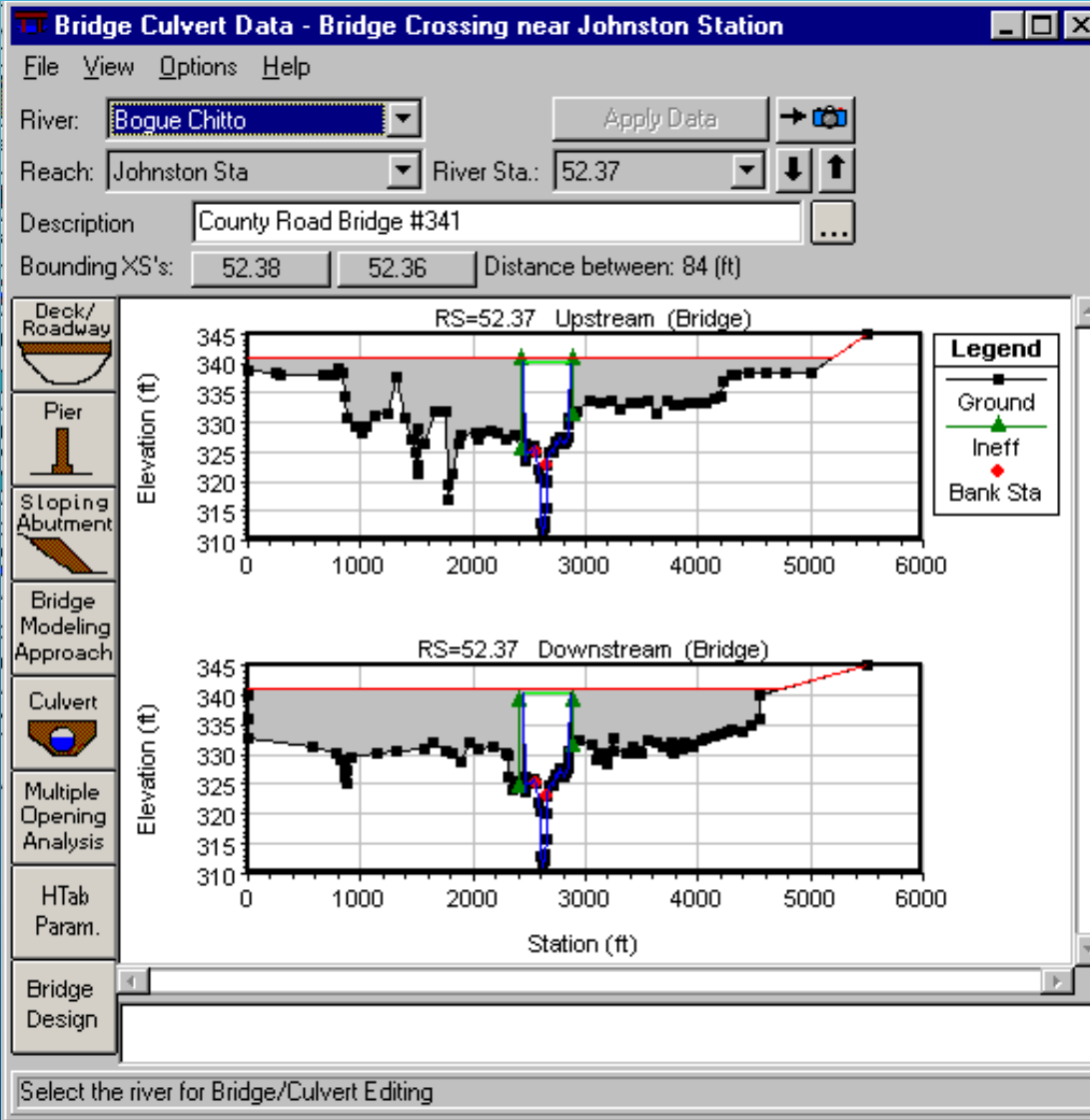

This brings up the Pier Data Editor where you can add the data for the pier(s) :

Use the “Copy Up to Down” button, if applicable:

Pier Data Editor

Add
Copy
Delete
Pier #
1
↓
↑

Del Row
Centerline Station Upstream

Ins Row
Centerline Station Downstream

Floating Pier Debris

Set Wd/Ht for all ...
 Apply floating debris to this pier

Clear all debris ...

Debris Width:   
 Debris Height:

Upstream
Downstream

	Pier Width	Elevation	Pier Width	Elevation	
1	20	300			▲     ▼
2	20	330			
3	5	330			
4	5	341			
5					
6					

OK
Cancel
Help
Copy Up to Down

Edit pier widths and elevations (ft)



The pier is then shown graphically on the plot:

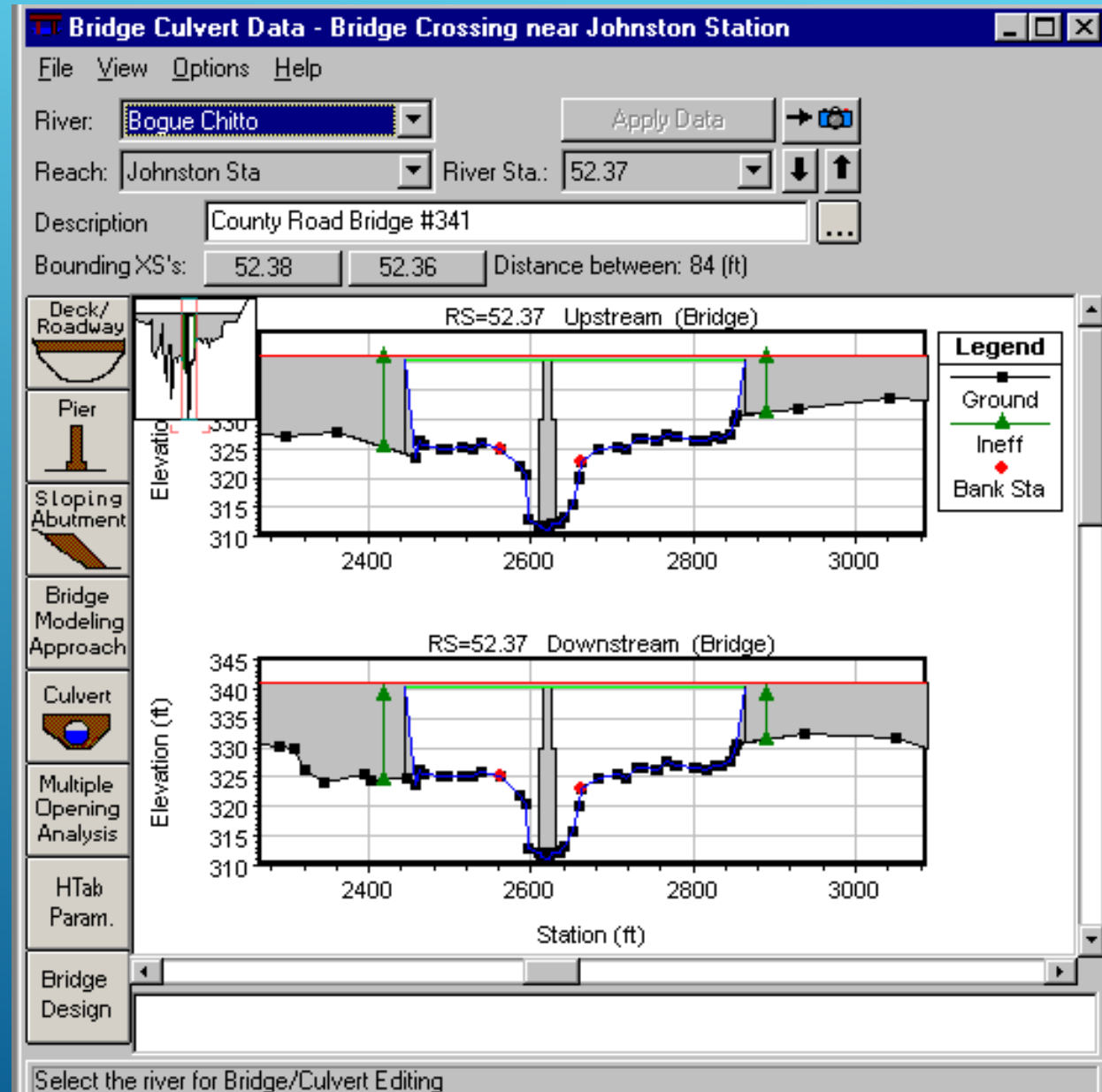

# BRIDGE MODELING APPROACH

The modeling options, including low flow and high flow modeling methods, are available by selecting the Bridge Modeling Approach button:

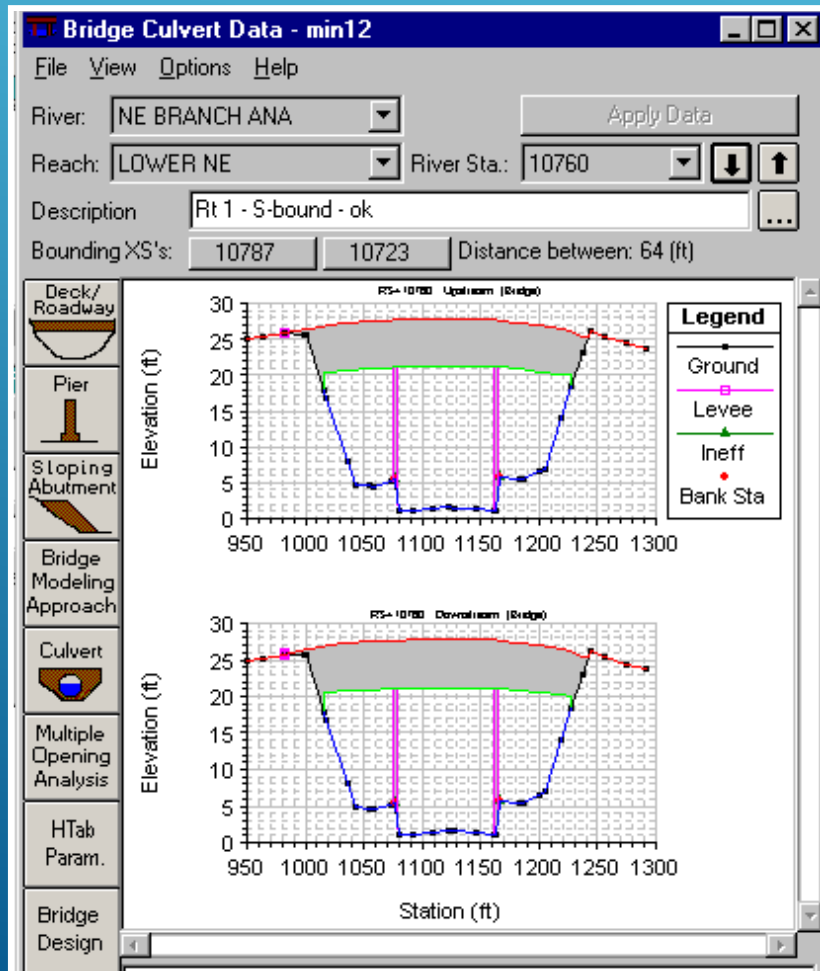

Bridge  
Modeling  
Approach

This brings up Bridge Modeling Approach Editor window. Notice the option to compute each type of low flow method and the option to select which one you use:

**Bridge Modeling Approach Editor**

Add Copy Delete Bridge # 1

**Low Flow Methods**

Use Compute

Energy (Standard Step)

Momentum Coef Drag Cd 2

Yarnell (Class A only) Pier Shape K 1.25

WSPRO Method (Class A only) WSPRO Variables

Highest Energy Answer

**High Flow Methods**

Energy Only (Standard Step)

Pressure and/or Weir

Submerged Inlet Cd (Blank for table)

Submerged Inlet + Outlet Cd

Max Low Chord (Blank for default)

OK Cancel Help

**Bridge Modeling Approach Editor**

Add Copy Delete Bridge # 1 [v] [↓] [↑]

**Low Flow Methods**

Use Compute

Energy (Standard Step)

Momentum Coef Drag Cd 2 [?]

Yarnell (Class A only) Pier Shape K 1.25 [?]

WSPRO Method (Class A only) WSPRO Variables

Highest Energy Answer

**High Flow Methods**

Energy Only (Standard Step)

Pressure and/or Weir

Submerged Inlet Cd (Blank for table) [ ]

Submerged Inlet + Outlet Cd [ ]

Max Low Chord (Blank for default) [ ]

OK Cancel Help

Use pressure and/or weir method for high flow

**Orifice Coef. - between 0.7 and 0.9**



# *Culverts*

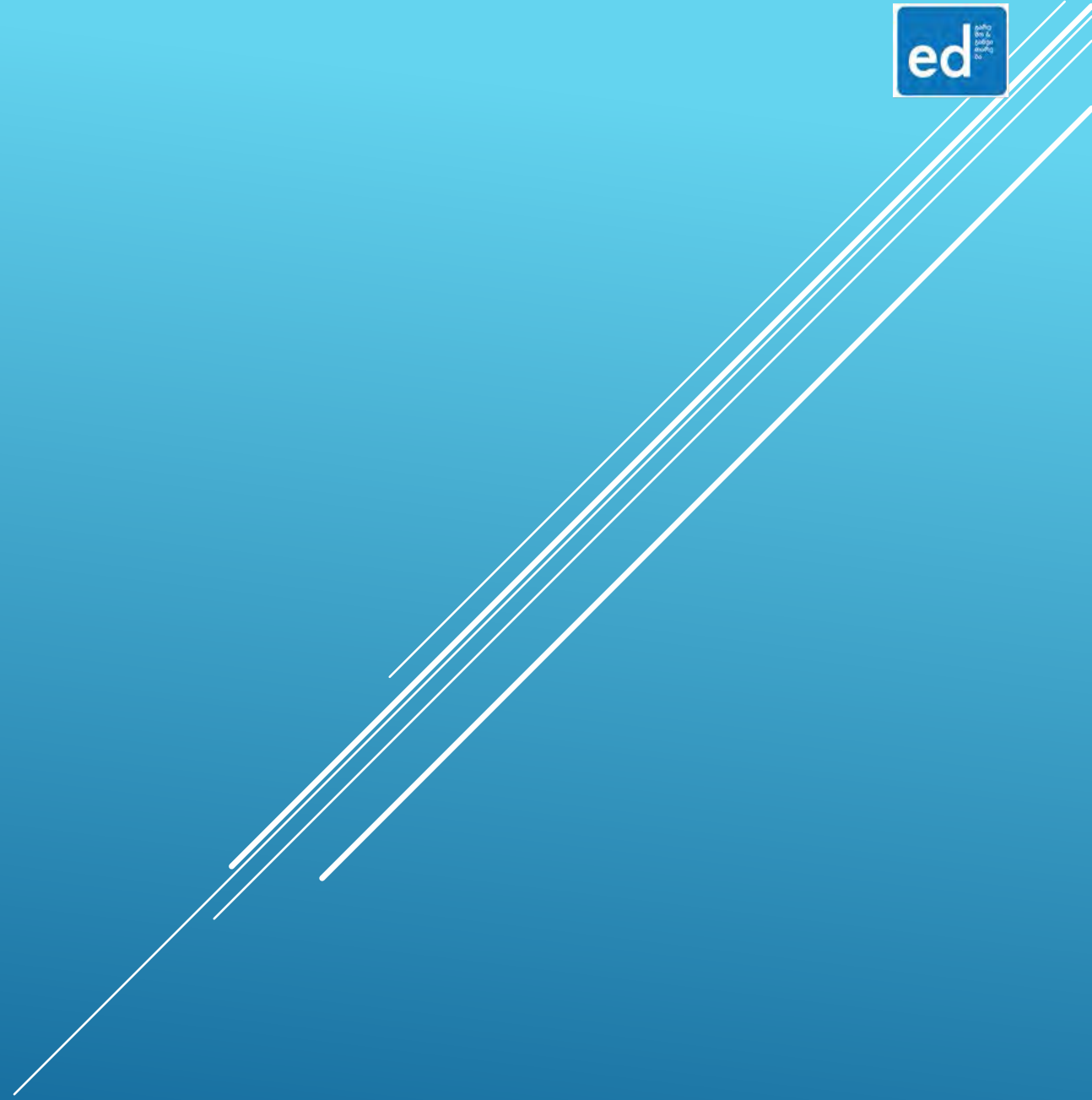

# WHAT ABOUT CULVERTS?

- Hydraulically short pipe capable of transporting water underneath a roadway



# TYPICAL CULVERT PROFILE

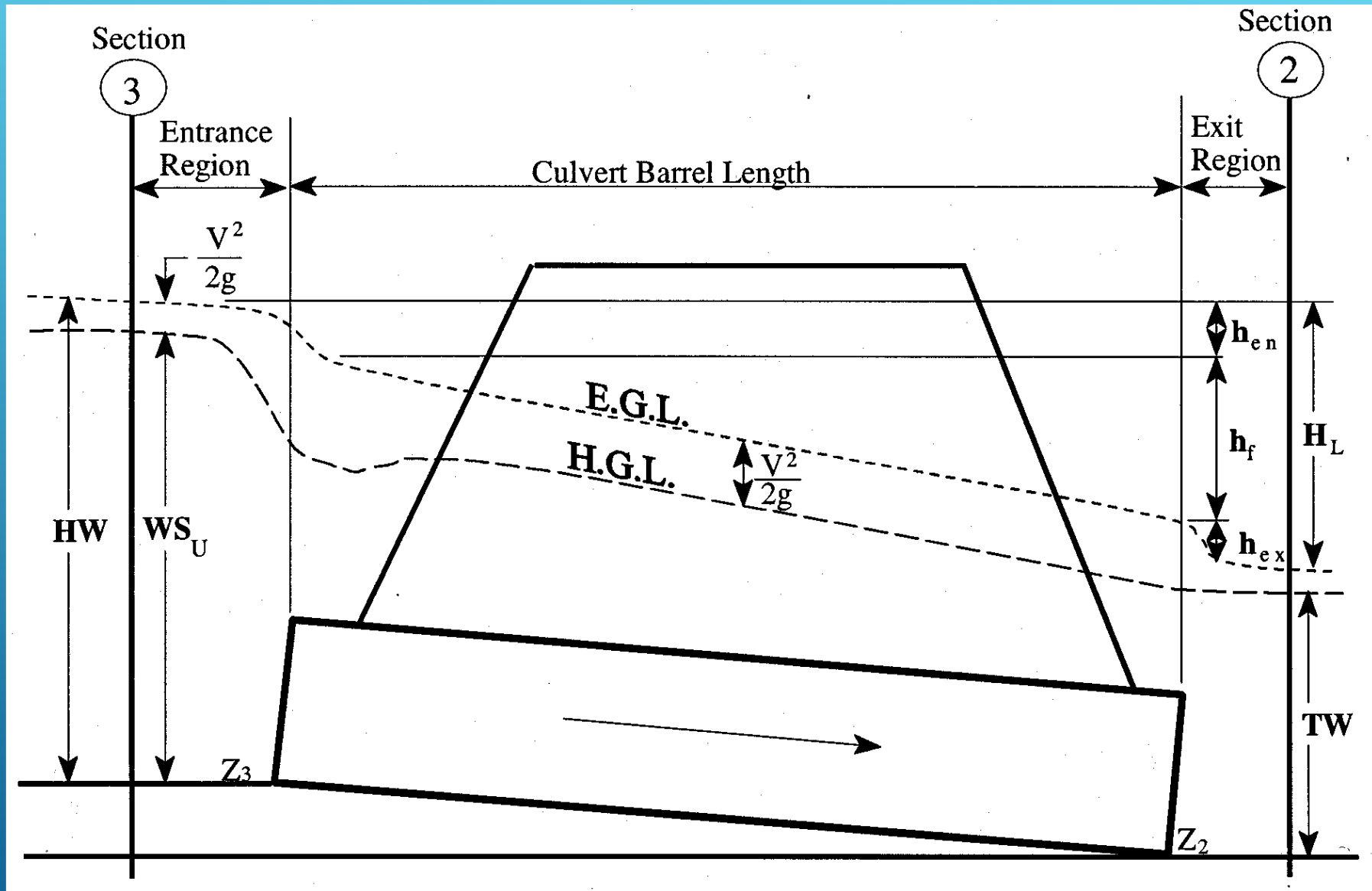

# CULVERT HYDRAULICS - INLET CONTROL

- ⇒ Occurs when flow capacity of the culvert entrance is less than the flow capacity of the culvert barrel.
- ⇒ Depends primarily on the geometry of the culvert entrance. Sharp entrance has less capacity.
- ⇒ Control section is just inside the entrance.
- ⇒ Flow passes through critical depth at this location or just downstream of this location.
- ⇒ Headwater is calculated assuming the entrance acts as a weir or as a sluice gate.
- ⇒ Usually occurs during lower flows.

# CULVERT HYDRAULICS - INLET CONTROL

## Unsubmerged Inlet:

$$\frac{HW_i}{D} = \frac{H_c}{D} + K \left[ \frac{Q}{AD^{0.5}} \right]^M - 0.5S$$

$$\frac{HW_i}{D} = K \left[ \frac{Q}{AD^{0.5}} \right]^M$$

Where: $HW_i$	= Headwater energy depth above the invert of the culvert inlet, feet
$D$	= Interior height of the culvert barrel, feet
$H_c$	= Specific head at critical depth ( $d_c + V_c^2/2g$ ), feet
$Q$	= Discharge through the culvert, cfs.
$A$	= Full cross sectional area of the culvert barrel, feet <sup>2</sup>
$S$	= Culvert barrel slope, feet/feet
$K, M, c, Y$	= Equation constants, which vary depending on culvert shape and entrance conditions

**Table 6.3**  
**Entrance Loss Coefficient for Pipe Culverts**

<b>Type of Structure and Design of Entrance</b>	<b>Coefficient, <math>k_{en}</math></b>
<b>Concrete Pipe Projecting from Fill (no headwall):</b>	
Socket end of pipe	0.2
Square cut end of pipe	0.5
<b>Concrete Pipe with Headwall or Headwall and Wingwalls:</b>	
Socket end of pipe (grooved end)	0.2
Square cut end of pipe	0.5
Rounded entrance, with rounding radius = 1/12 of diameter	0.2
<b>Concrete Pipe:</b>	
Mitered to conform to fill slope	0.7
End section conformed to fill slope	0.5
Beveled edges, 33.7 or 45 degree bevels	0.2
Side slope tapered inlet	0.2
<b>Corrugated Metal Pipe or Pipe-Arch:</b>	
Projected from fill (no headwall)	0.9
Headwall or headwall and wingwalls square edge	0.5
Mitered to conform to fill slope	0.7
End section conformed to fill slope	0.5
Beveled edges, 33.7 or 45 degree bevels	0.2
Side slope tapered inlet	0.2

Ref: Hydraulic Reference Manual

**Table 6.4**  
**Entrance Loss Coefficient for Reinforced Concrete Box Culverts**

Type of Structure and Design of Entrance	Coefficient, $k_{en}$
<b>Headwall Parallel to Embankment (no wingwalls):</b>	
Square-edged on three edges	0.5
Three edges rounded to radius of 1/12 barrel dimension	0.2
<b>Wingwalls at 30 to 75 degrees to Barrel:</b>	
Square-edge at crown	0.4
Top corner rounded to radius of 1/12 barrel dimension	0.2
<b>Wingwalls at 10 to 25 degrees to Barrel:</b>	
Square-edge at crown	0.5
<b>Wingwalls parallel (extension of sides):</b>	
Square-edge at crown	0.7
Side or slope tapered inlet	0.2

Ref: Hydraulic Reference Manual

# CULVERT HYDRAULICS - INLET CONTROL

## Submerged Inlet:

$$\frac{HW_i}{D} = c \left[ \frac{Q}{AD^{0.5}} \right]^2 + Y - 0.5S$$

Where: $HW_i$	= Headwater energy depth above the invert of the culvert inlet, feet
$D$	= Interior height of the culvert barrel, feet
$H_c$	= Specific head at critical depth ( $d_c + V_c^2/2g$ ), feet
$Q$	= Discharge through the culvert, cfs.
$A$	= Full cross sectional area of the culvert barrel, feet <sup>2</sup>
$S$	= Culvert barrel slope, feet/feet
$K, M, c, Y$	= Equation constants, which vary depending on culvert shape and entrance conditions

# CULVERT HYDRAULICS - OUTLET CONTROL

- ⇒ Occurs when flow capacity is controlled by the tailwater conditions or the flow capacity of the culvert barrel.
- ⇒ Entrance, exit, and friction losses are computed in determining controlling headwater elevation.
- ⇒ Bernoulli equation is used to compute the change in energy through the culvert.

$$h_f = L \left( \frac{Qn}{1.486 AR^{2/3}} \right)^2$$

# Culvert Flow Types (8 modes)

Inlet Control (4 modes)

Outlet Control (4 modes)

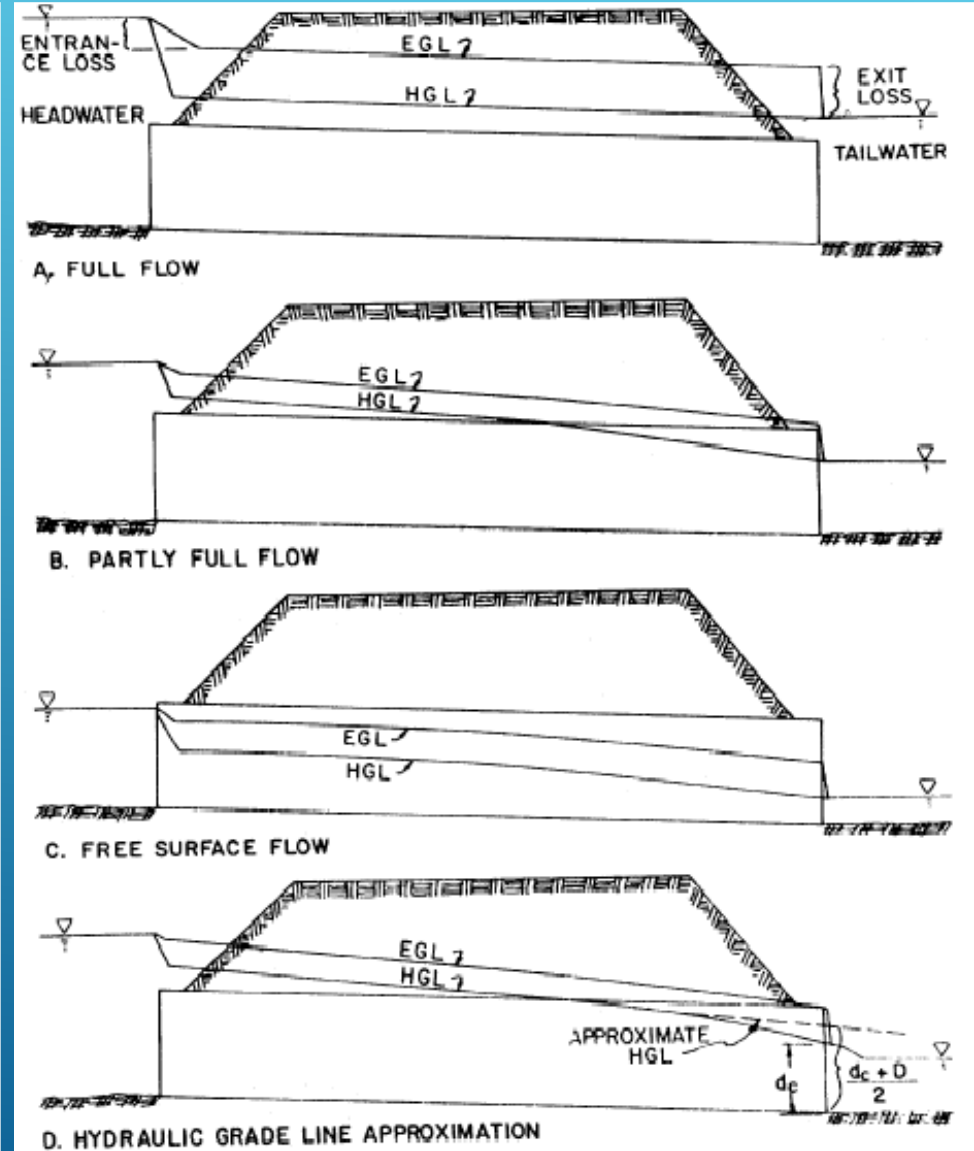
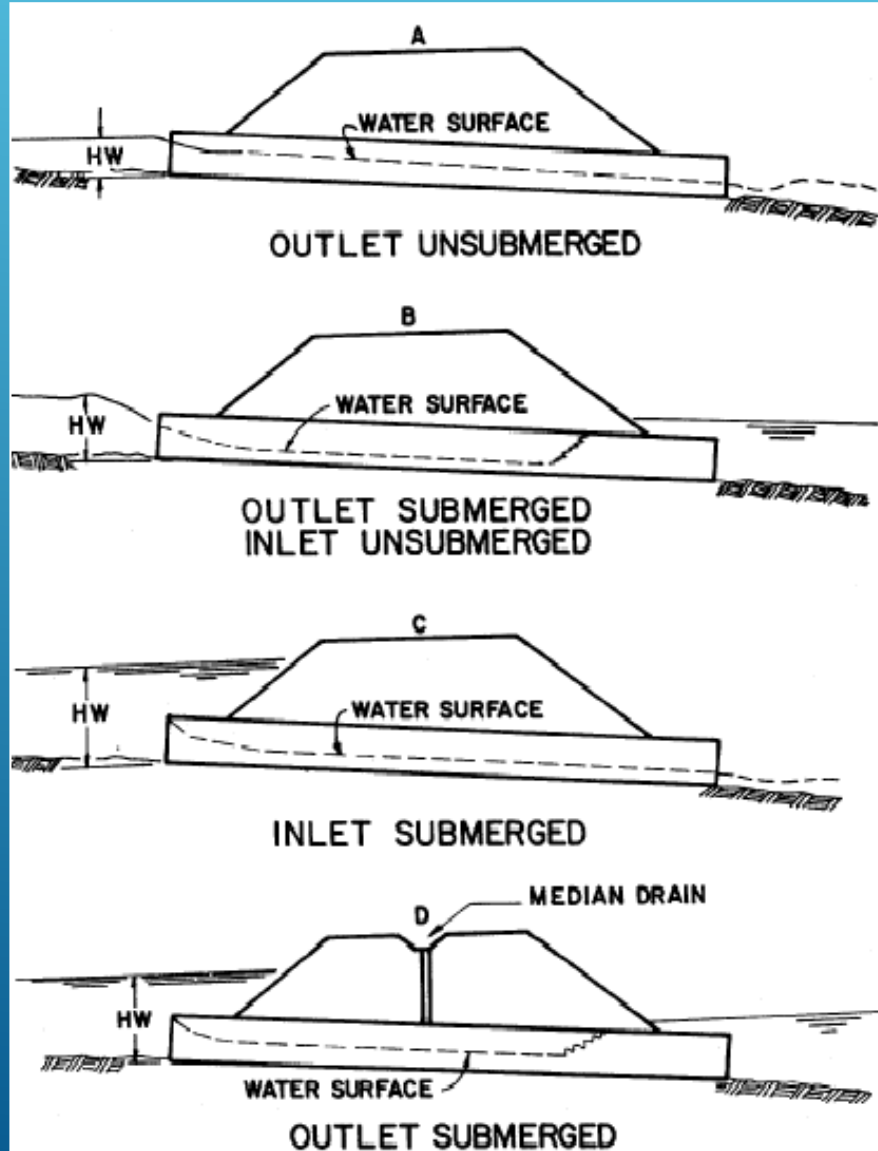

# CULVERT PERFORMANCE WITH ROADWAY OVERTOPPING

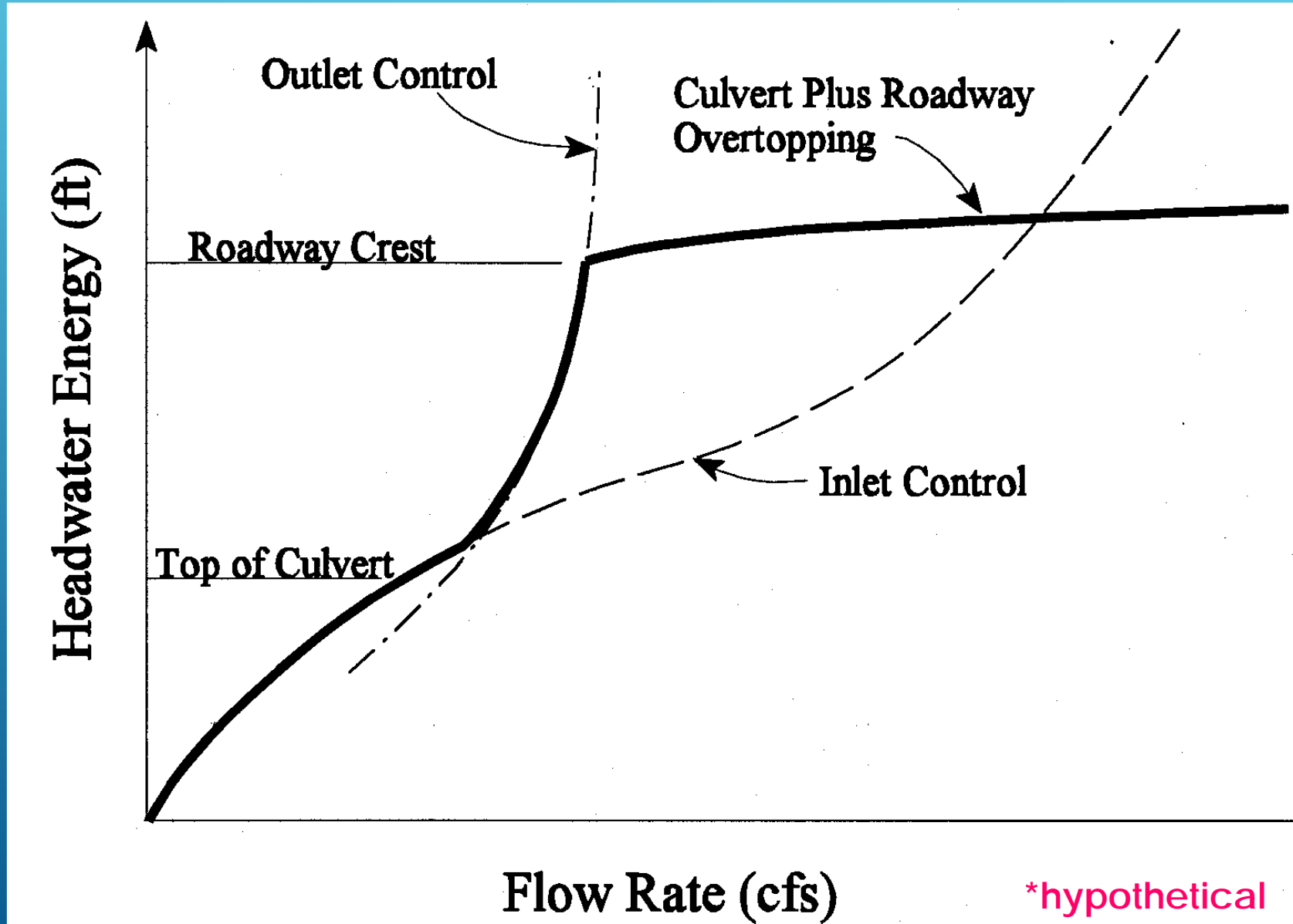

# HOW DOES HEC-RAS DEAL WITH CULVERTS?

- ▶ Same as FHWA
  - ▶ computes headwater due to inlet control and outlet control and selects the higher value
  - ▶ Outlet control FHWA chart only consider case where culvert is flowing full. HECRAS allows culvert to operate partially full under outlet control.

# How does HEC-RAS deal with Culverts?

- Weir flow and culvert flow as a combination
- Direct Step Method for culvert flow
- Standard Step Method for weir flow
- Same modeling approach as a bridge
  - once upstream EGL and WSE is calculated, computations proceed using standard step method
  - includes inlet control (FHWA)
  - Uses different equations for low and pressure flow

# CULVERT TYPES IN HEC-RAS

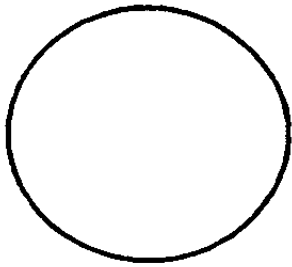

**Circular**

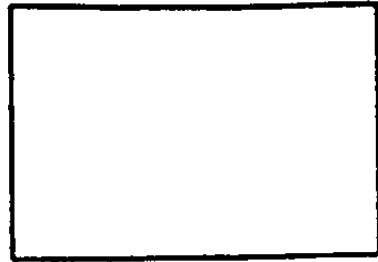

**Box (Rectangular)**

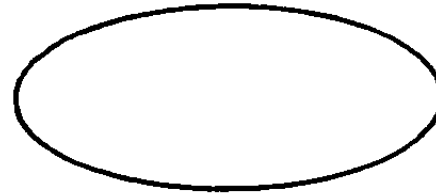

**Elliptical**



**Low Profile Arch**



**Semi-Circle**

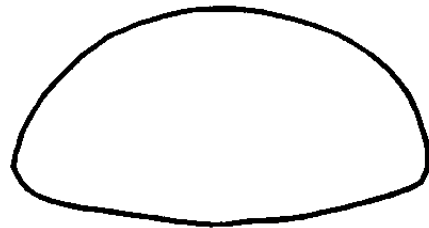

**Pipe Arch**



**Arch**

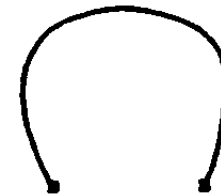

**High Profile Arch**

# CULVERTS INLETS AND OUTLETS

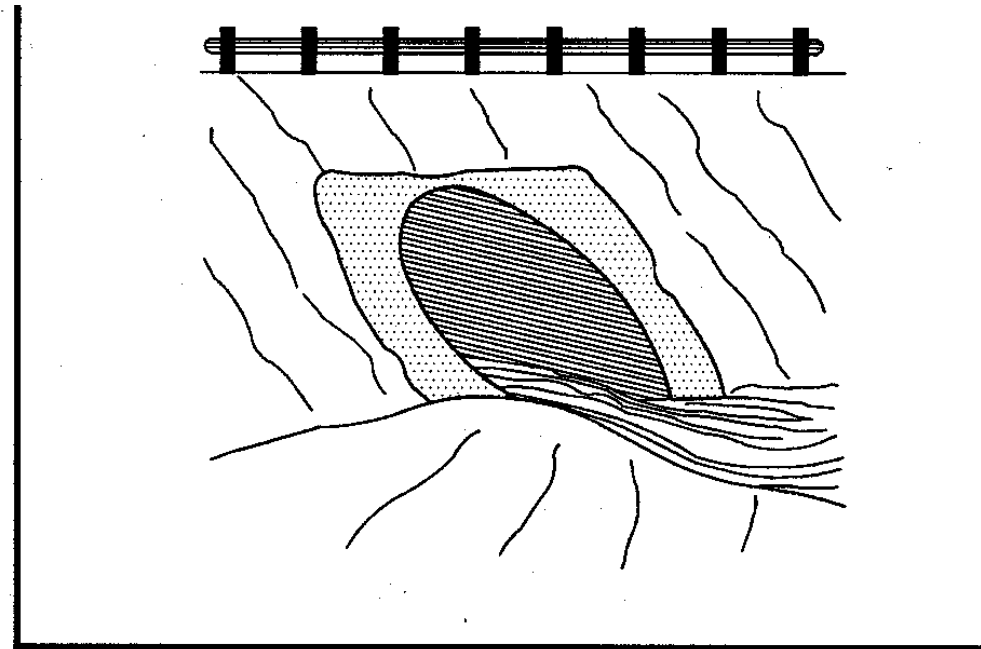
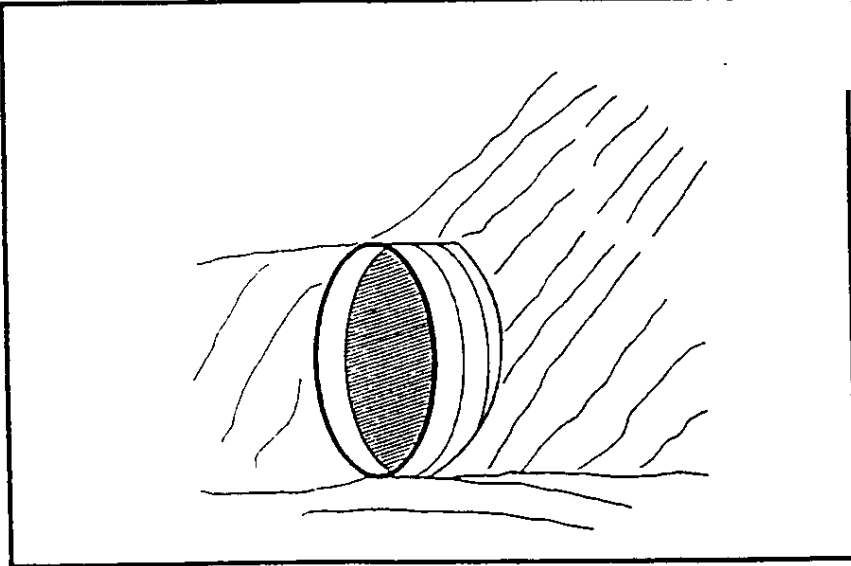
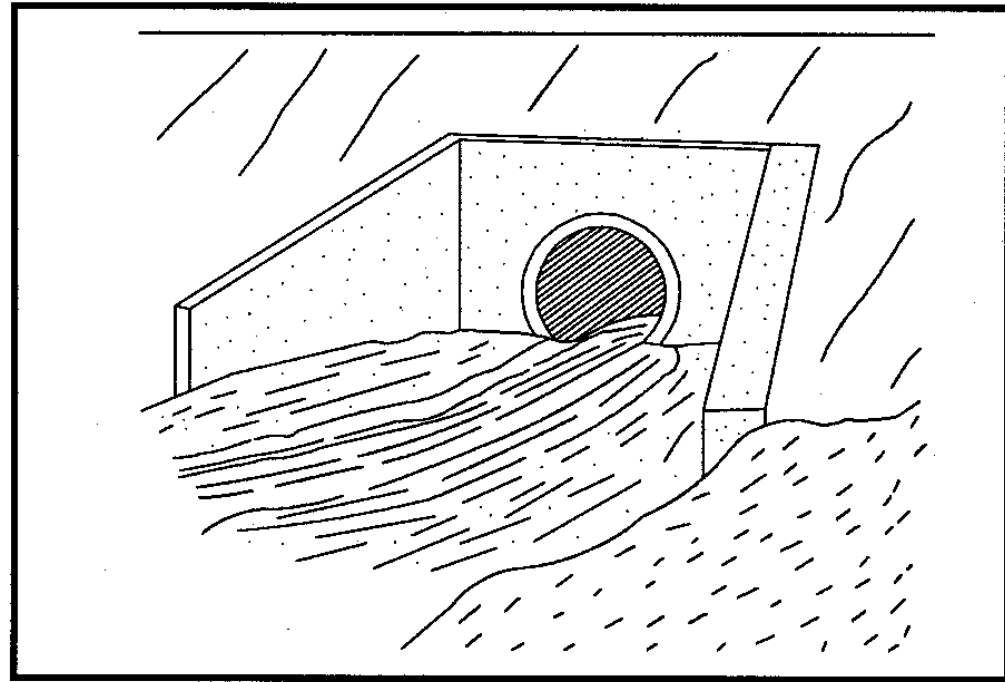

**Figure 6.12**  
**Culvert Inlet Projecting from Fill**

# CROSS SECTION LOCATIONS (4 OF THEM)

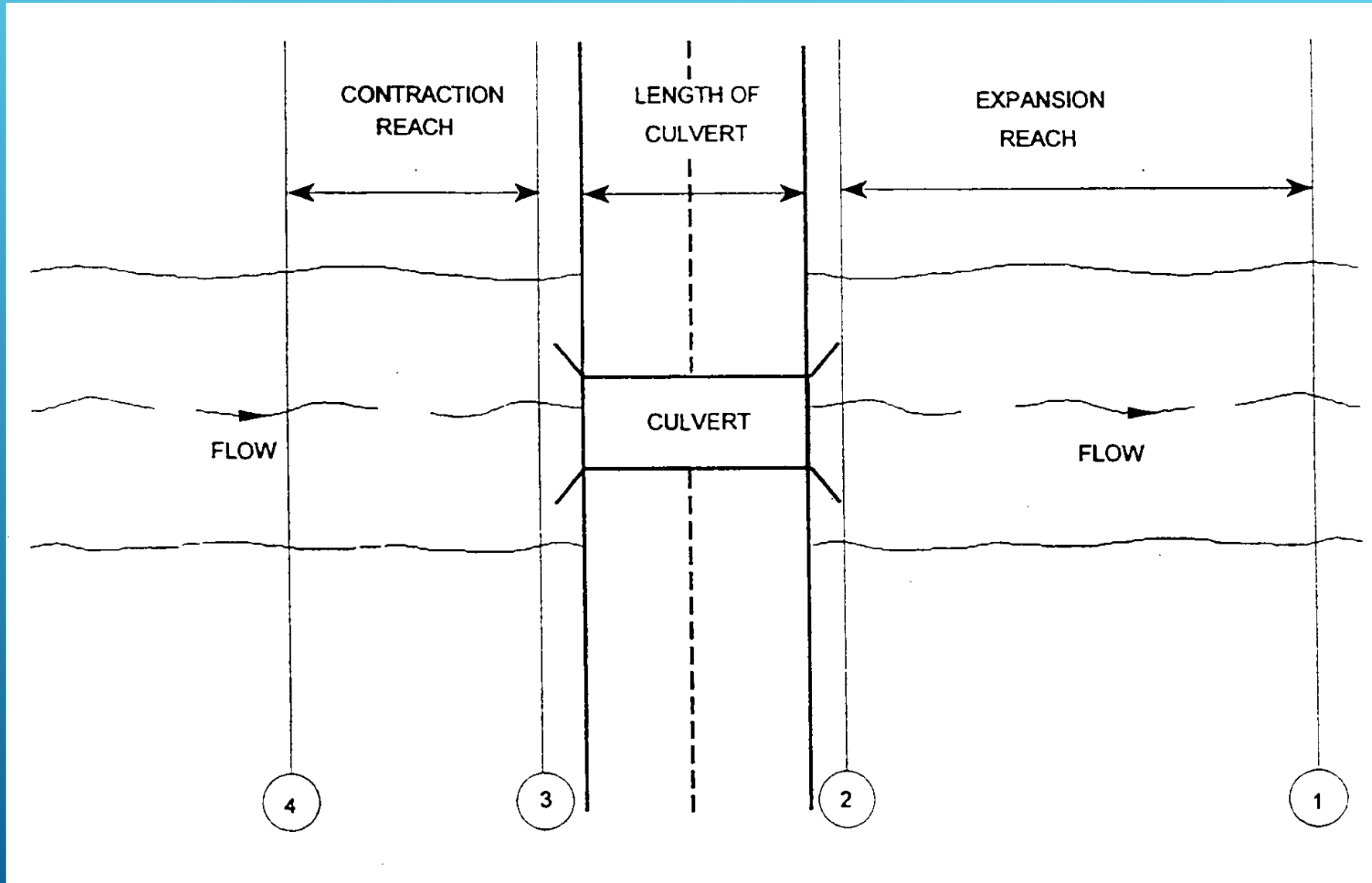

-similar to a bridge

# ADDING THE CULVERT(S)



# INPUT REQUIREMENTS FOR CULVERTS

- ▶ Roadway Deck Information
- ▶ Culvert Structure Data

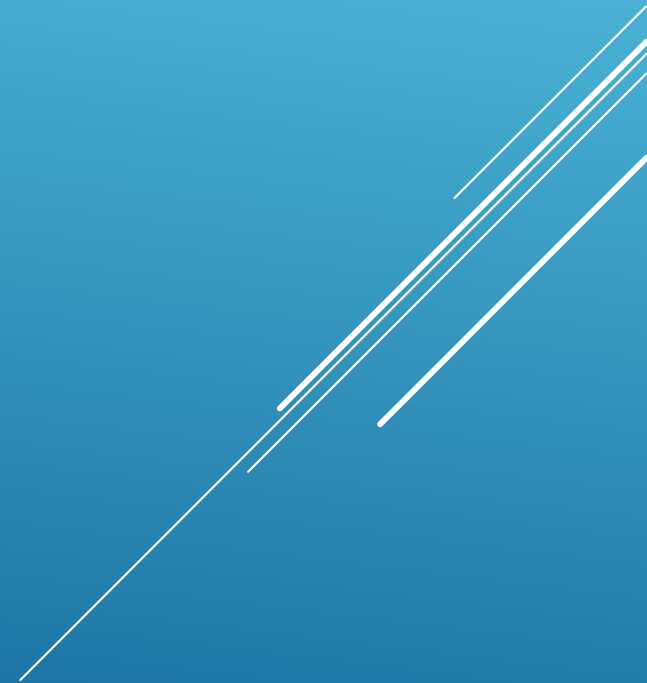

# CULVERT GROUPS IN HEC-RAS

- ↳ Up to 10 different culvert groups allowed per crossing. Any difference in shape, invert elevations, slope, roughness coefficient, or chart or scale number requires a new group.
- ↳ Up to 25 identical culverts may be in each group per crossing.

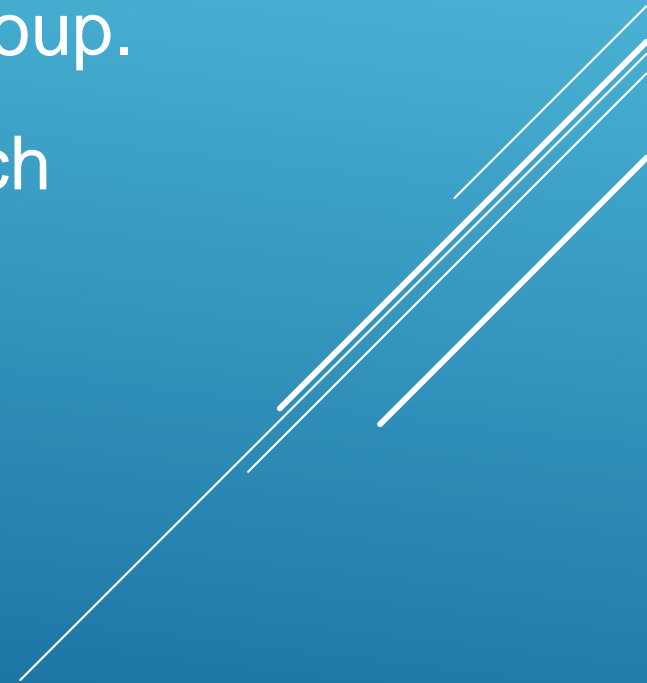

- ▶ Culvert ID
- ▶ Solution criteria (inlet, outlet, or highest energy grade line)
- ▶ Shape (circular, box, arch, etc.)
- ▶ Dimensions (diameter, width, etc)
- ▶ FHWA chart # (pages 6-25,26 of hydraulic reference manual)
- ▶ FHWA scale (same table as chart #)
- ▶ Distance to upstream cross section

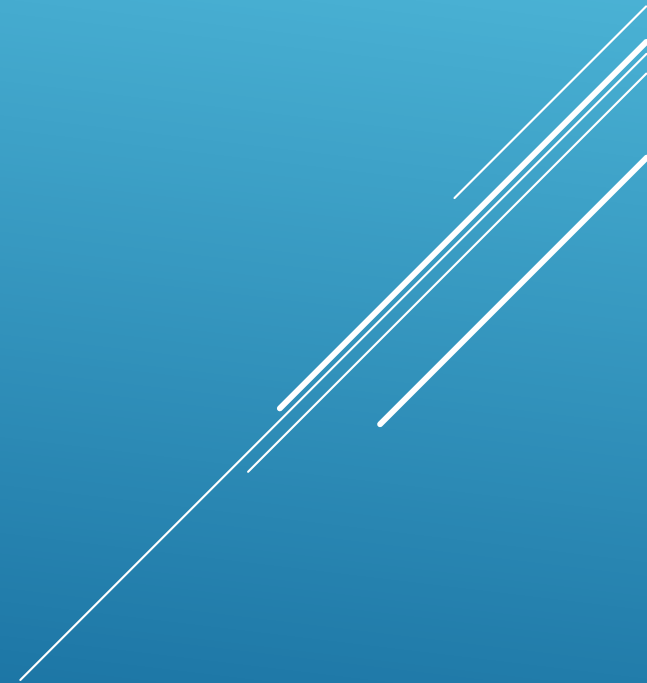

# INPUT REQUIREMENTS FOR CULVERTS (CONTINUED)

- ▶ Length
- ▶ Entrance loss coefficient (tables 6.3 and 6.4 of hydraulic reference manual)
- ▶ Exit loss coefficient (0.3 to 1)
- ▶ Manning's 'n' value (tables 6.1 and 6.2 of hydraulic reference manual)
- ▶ U. S. And D.S. invert elevations
- ▶ Centerline stations in relation to U. S. And D. S. cross sections



# INPUT REQUIREMENTS FOR CULVERTS ROADWAY DATA

- ▶ Roadway width
- ▶ Distance to U.S. Cross section
- ▶ Weir coefficient
- ▶ Station - elevation points

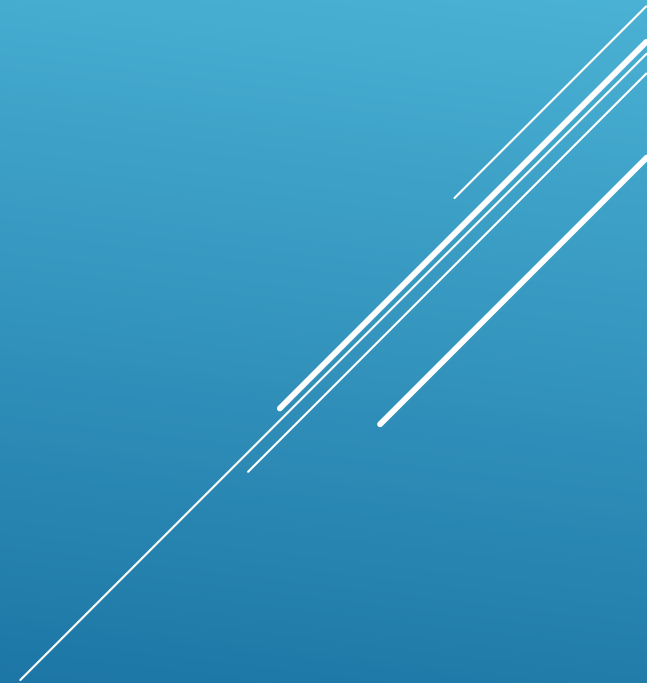

# ADDING THE CULVERT(S)

- Establish the geometry
- Select the Brdg/Culv button from the geometry data window:

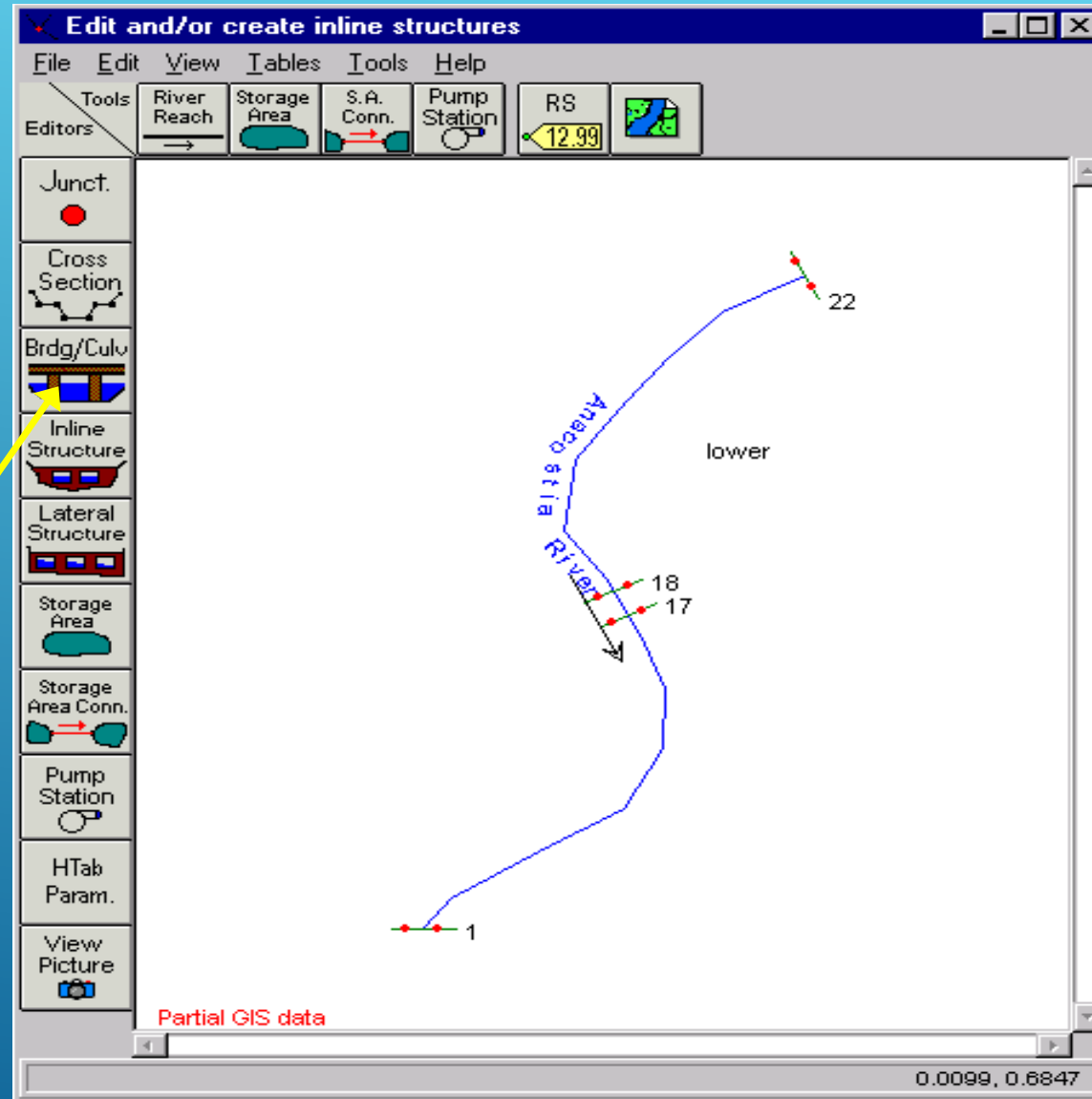
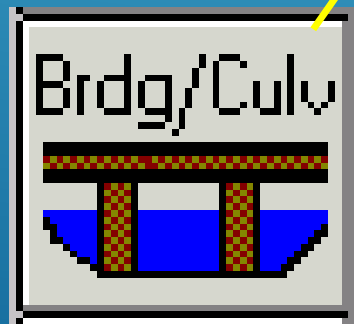

# ADDING THE CULVERT(S)

This brings up the Bridge Culvert Data window:

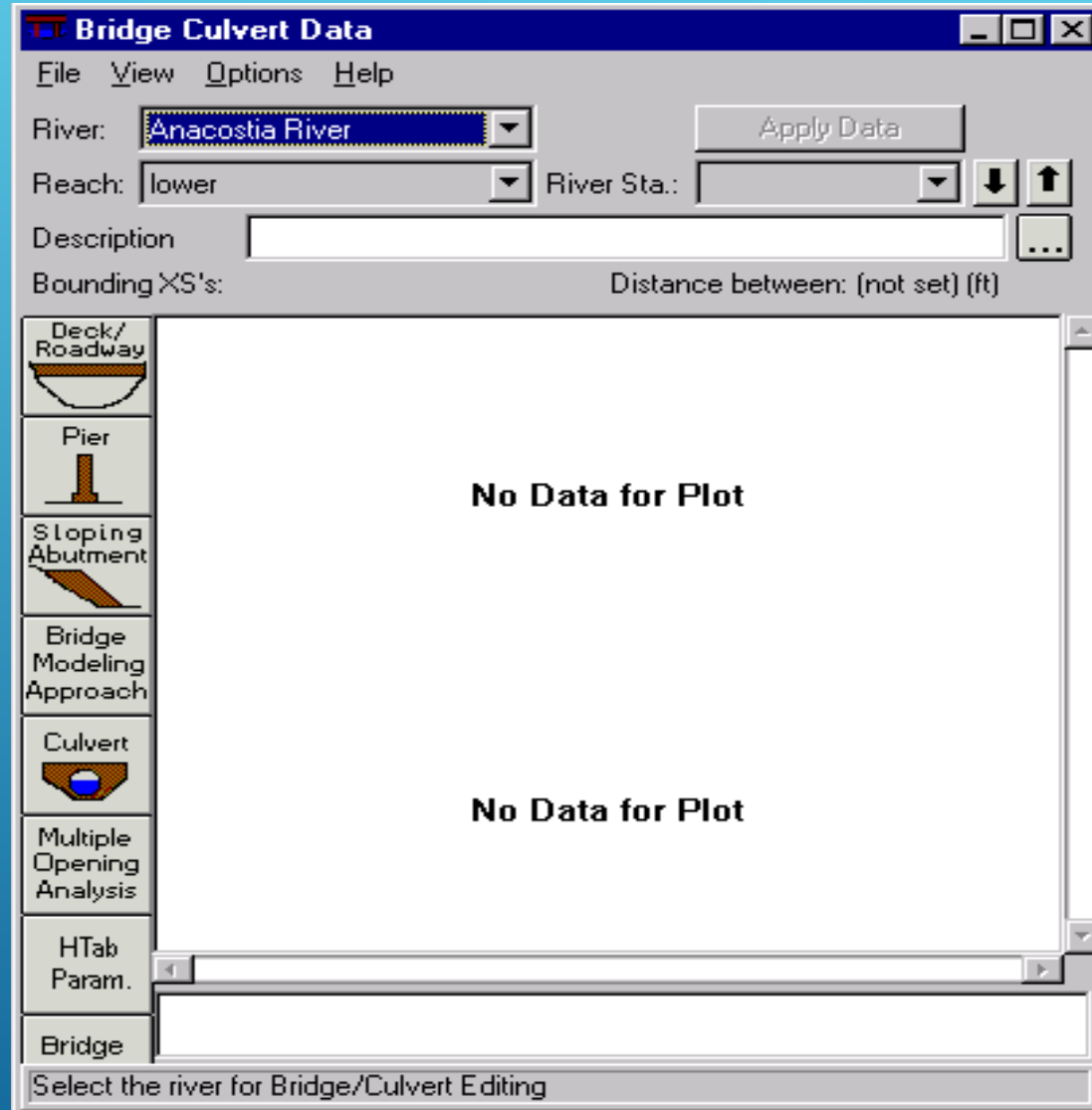

# ADDING THE CULVERT(S)

From the options menu, select "Add a Bridge and/or Culvert":



# ADDING THE CULVERT(S)

This brings up a window asking for the river station of the bridge. It will locate the bridge numerically between cross-sections:

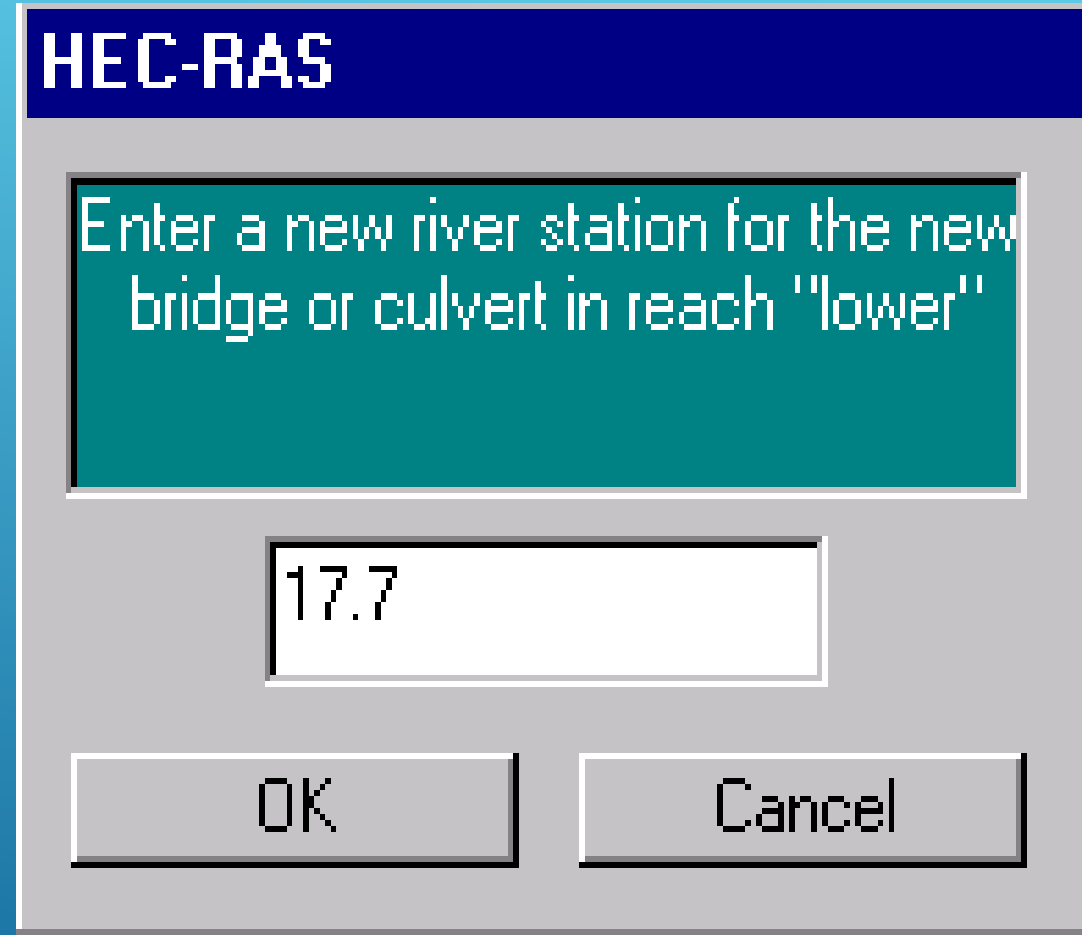

The image shows a screenshot of a software dialog box titled "HEC-RAS". The dialog box has a dark blue header with the text "HEC-RAS" in white. Below the header is a green text area containing the instruction: "Enter a new river station for the new bridge or culvert in reach 'lower'". Below the text area is a white input field containing the number "17.7". At the bottom of the dialog box are two buttons: "OK" and "Cancel".

# CROSS SECTION LOCATIONS

The culvert must be bounded by two established cross sections (2 and 3) as well as sections that represent full channel flow (1 and 4).

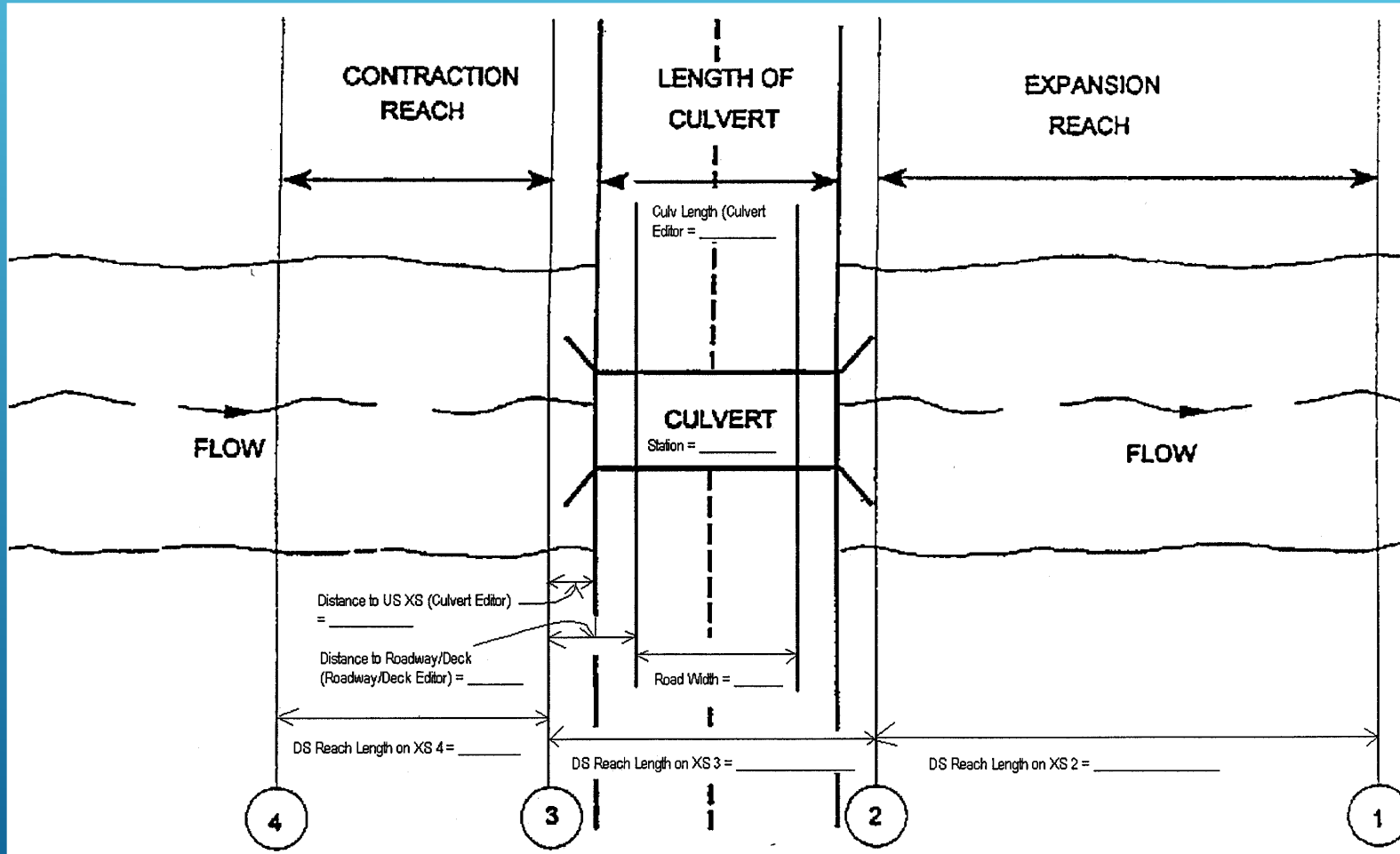

# ADDING THE CULVERT(S)

Once you click on 'OK', the program will bring up a window with the adjacent upstream and downstream cross-sections plotted.

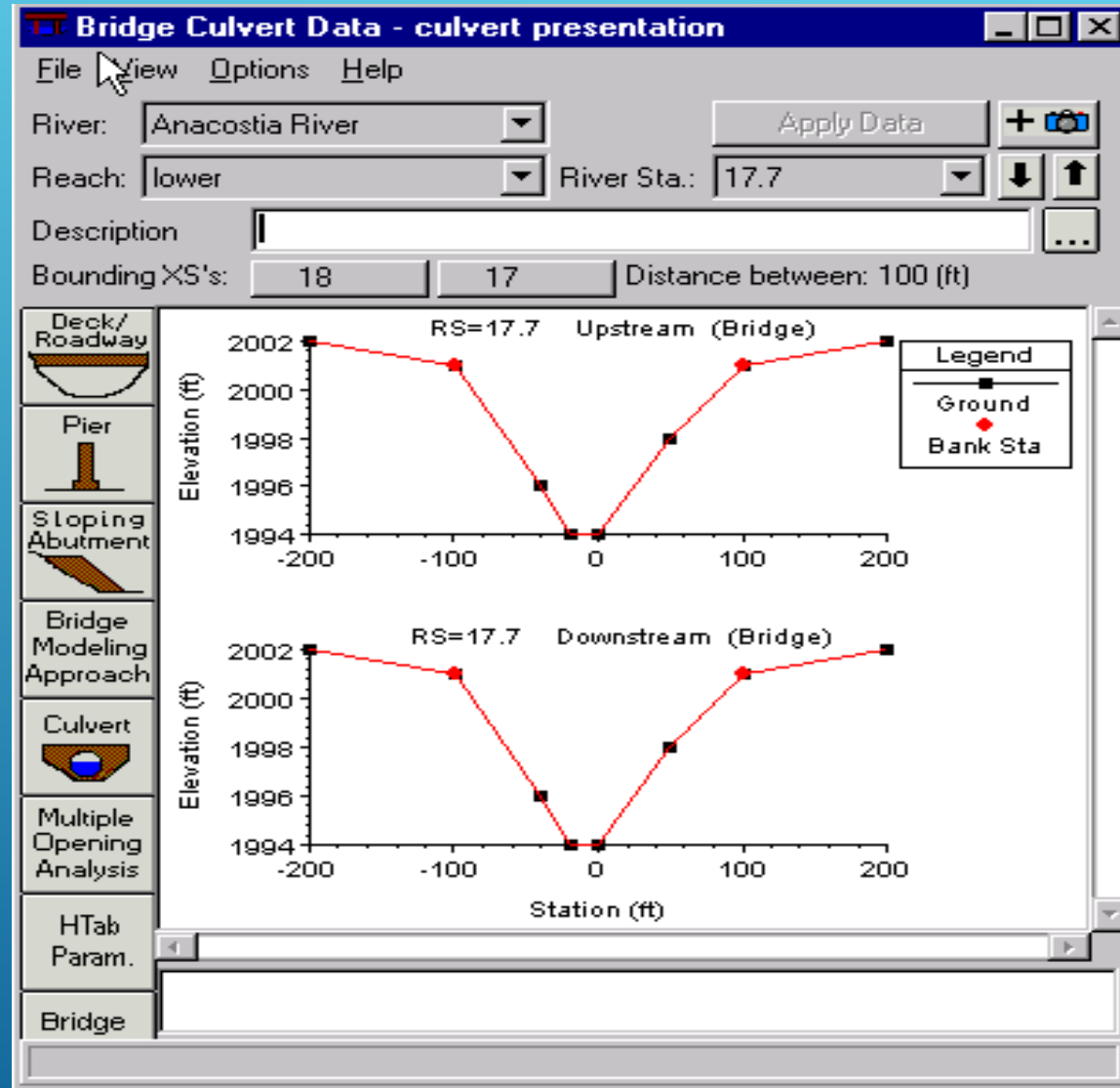

# ADDING THE CULVERT(S)

It is often a good idea to add a description of the culvert which include the road name.

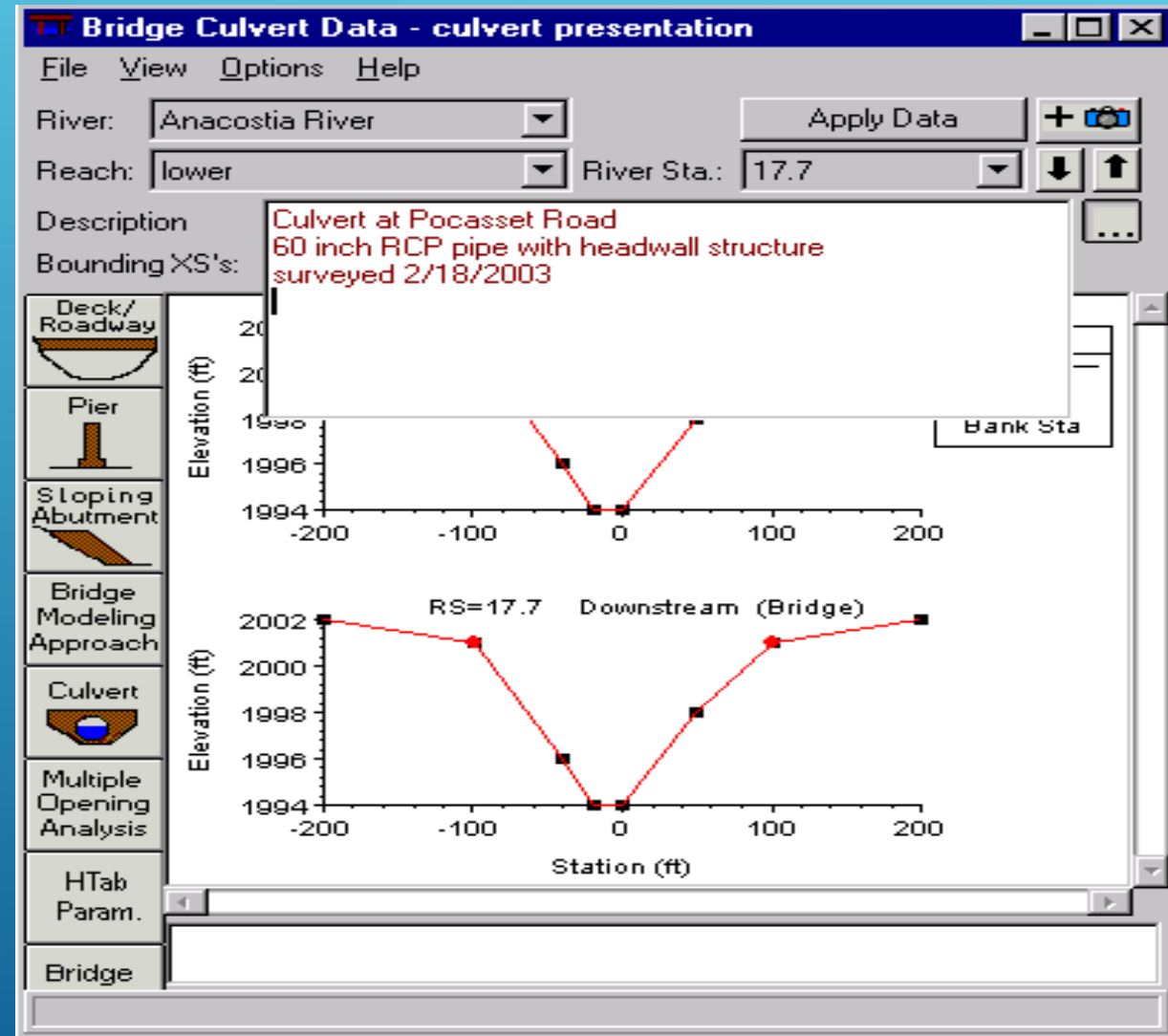

# ADDING THE CULVERT(S)

Next, select the Deck/Roadway button from the Bridge data window:



**Bridge Culvert Data - culvert presentation**

File View Options Help

River: **Anacostia River** Apply Data + [Camera]

Reach: lower River Sta.: 17.7 [Down] [Up]

Description: Culvert at Pocasset Road ...

Bounding XS's: 18 17 Distance between: 100 (ft)

Deck/Roadway  
Pier  
Sloping Abutment  
Bridge Modeling Approach  
Culvert  
Multiple Opening Analysis  
HTab Param.  
Bridge

Legend  
Ground  
Bank Sta

RS=17.7 Upstream (Bridge)

RS=17.7 Downstream (Bridge)

Elevation (ft)

Station (ft)

Select the river for Bridge/Culvert Editing

# ADDING THE CULVERT(S)

Notice the weir coefficient and max submergence window are showing the default values:

**Deck/Roadway Data Editor**

Del Row		Distance	Width	Weir Coef
Ins Row				2.6

Upstream				Downstream			
	Station	high chord	low chord	Station	high chord	low chord	
1							
2							
3							
4							
5							
6							
7							
8							

U.S Embankment SS:       D.S Embankment SS:

**Weir Data**

Max Submergence:       Min Weir Flow El:

**Weir Crest Shape**

Broad Crested  
 Ogee

OK      Cancel      Clear      Copy Up to Down

Enter distance between upstream cross section and deck/roadway. (ft)

# CROSS SECTION LOCATIONS

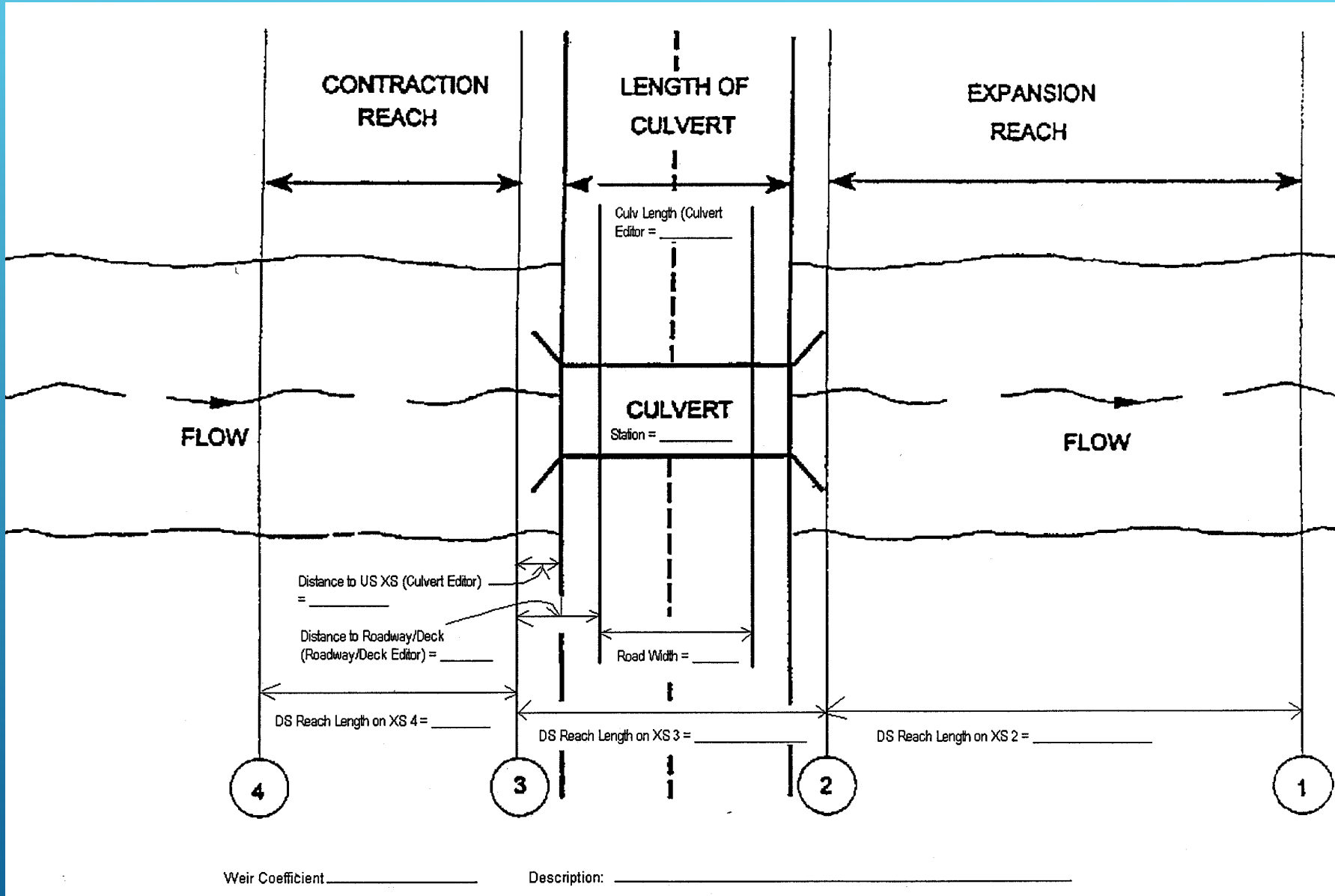

# ADDING THE CULVERT(S)

Enter the data for the required values. Note that the U.S. and D.S. side slopes are for graphical eye wash purposes. Also note the low elev for the low chord.

**Deck/Roadway Data Editor**

Del Row		Distance	Width	Weir Coef
Ins Row		40	20	2.6

Upstream				Downstream		
	Station	high chord	low chord	Station	high chord	low chord
1	-200	2002	1950	-200	2002	1950
2	-100	2001.7	1950	-100	2001.7	1950
3	50	2001.3	1950	50	2001.3	1950
4	200	2002	1950	200	2002	1950
5						
6						
7						
8						

U.S Embankment SS  D.S Embankment SS

Weir Data  
 Max Submergence:  Min Weir Flow El:

Weir Crest Shape  
 Broad Crested  
 Ogee

OK Cancel Clear Copy Up to Down

Enter elevation to start checking for weir flow.

The maximum submergence is the ratio of d/s to u/s energy. When this ratio is exceeded in a bridge analysis, HECRAS will switch from pressure and weir flow equations to the energy method. In culvert analysis, weir flow is always

# ADDING THE CULVERT(S)

After selecting OK from the bridge deck window, it replots the U.S. and D.S. x-sections showing the filled in road section:

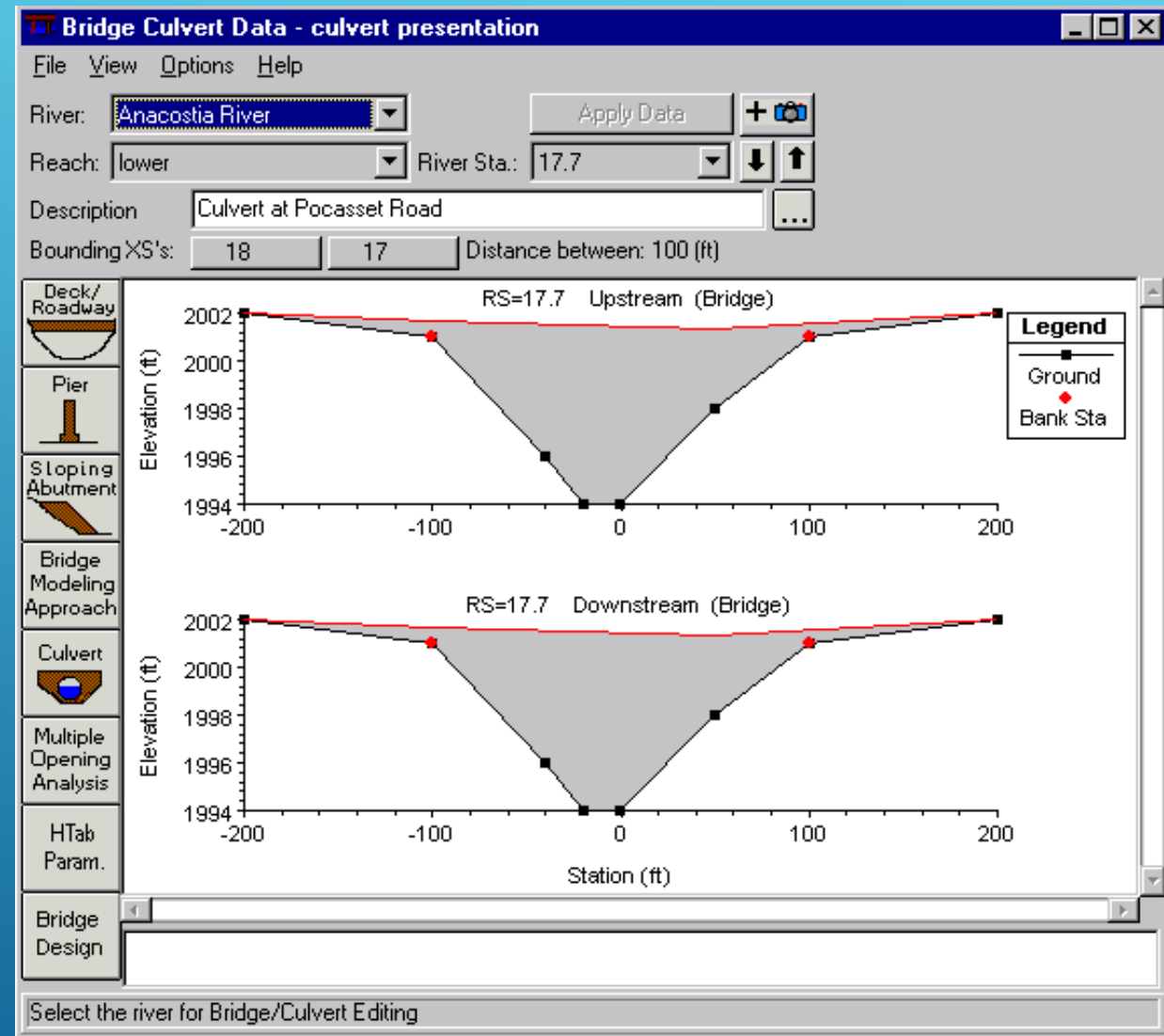

# ADDING THE CULVERT(S)

To enter the culvert data, first select the Culvert button:

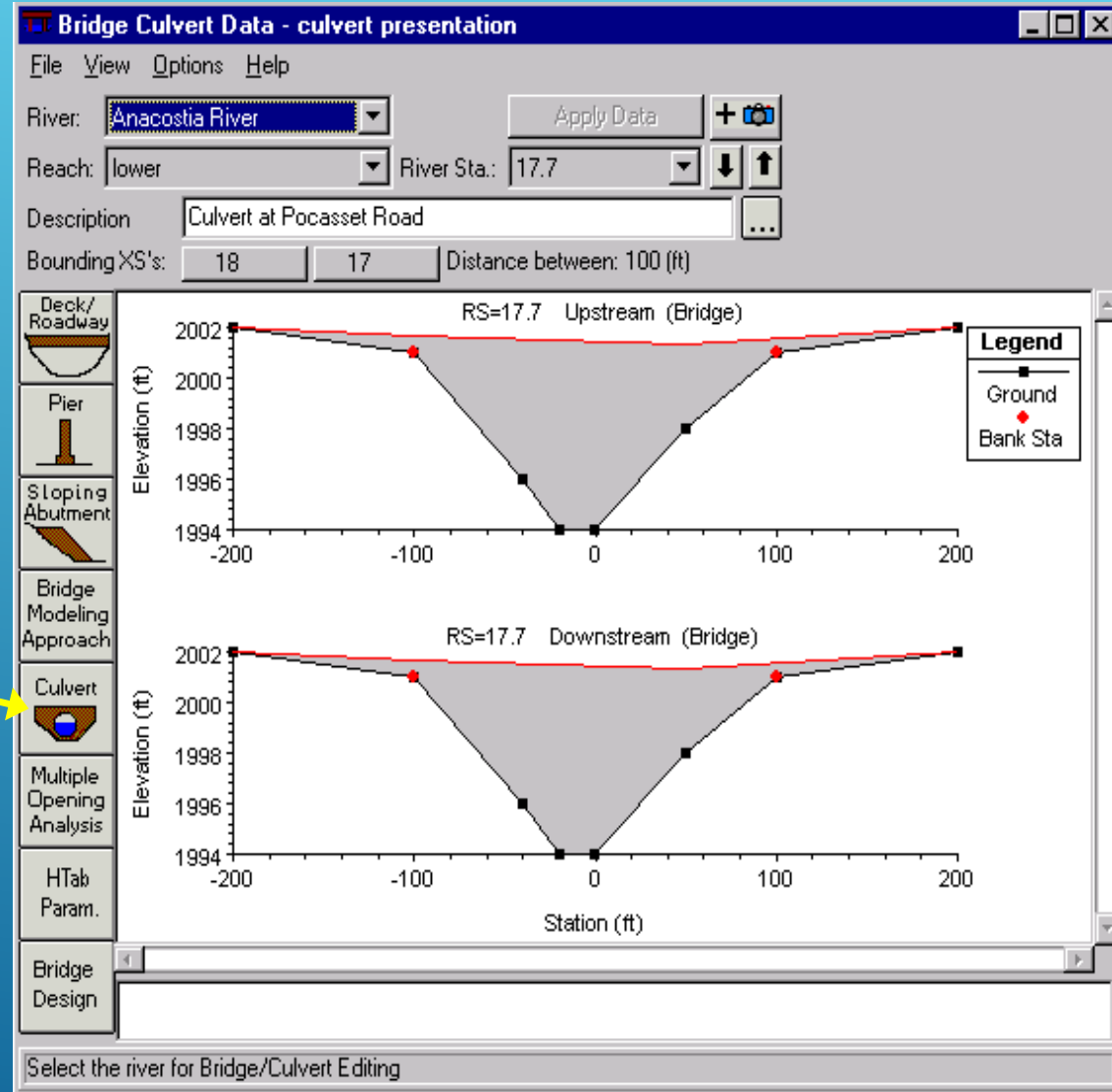
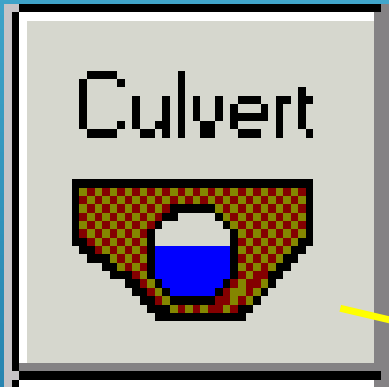

# ADDING THE CULVERT(S)

This brings up the Culvert Data Editor window:

**Culvert Data Editor**

Culvert ID:

Solution Criteria:

Shape: 
 Span: 
 Diam:

Chart #:

Scale #:

Distance to Upstrm XS: 
 Upstream Invert Elev:

Culvert Length: 
 Downstream Invert Elev:

Entrance Loss Coeff: 

 # identical barrels:

Exit Loss Coeff:

Manning's n for Top:

Manning's n for Bottom:

Depth to use Bottom n:

Depth Blocked:

Centerline Stations		
	Upstream	Downstream
1		
2		
3		
4		

Select culvert to edit

# ADDING THE CULVERT(S)

Enter the data

Table 6.3 or 6.4,  
HRM, HDS 5 (for  
outlet control or  
click

Table 6.1 or 6.2,  
HRM

or click

and select OK ...

**Culvert Data Editor**

Add Copy Delete Culvert ID **Culvert #1**

Solution Criteria **Highest U.S. EG** Rename ...

Shape **Circular** Span  Diam

Chart # **1 - Concrete Pipe Culvert**

Scale # **1 - Square edge entrance with headwall**

Distance to Upstrm XS:  Upstream Invert Elev:

Culvert Length:  Downstream Invert Elev:

Entrance Loss Coeff:  # identical barrels:

Exit Loss Coeff:

Manning's n for Top:

Manning's n for Bottom:

Depth to use Bottom n:

Depth Blocked:

Centerline Stations			
	Upstream	Downstream	
1	-14.	-14.	
2	-6.	-6.	
3			
4			

OK Cancel Help

Select culvert to edit

# ADDING ANOTHER CULVERT

Can add multiple culverts at a location or multiple barrels of the same culvert

Note: each individual culvert must have a constant

- slope
- cross section
- material
- type
- length
- discharge

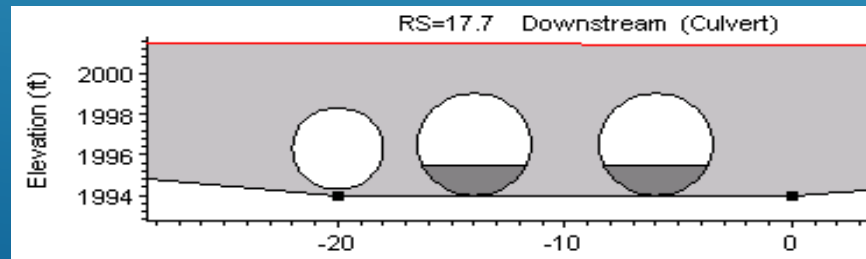

**Culvert Data Editor**

Culvert ID:

Solution Criteria:

Shape: 
 Span: 
 Diam:

Chart #:

Scale #:

Distance to Upstrm XS: 
 Upstream Invert Elev:

Culvert Length: 
 Downstream Invert Elev:

Entrance Loss Coeff: 
 # identical barrels:

Exit Loss Coeff:

Manning's n for Top:

Manning's n for Bottom:

Depth to use Bottom n:

Depth Blocked:

Centerline Stations		
	Upstream	Downstream
1	-20.	-20.
2		
3		
4		

Select culvert to edit

# ADDING THE CULVERT(S)

After you click 'OK', the plot will be updated to show the culvert:

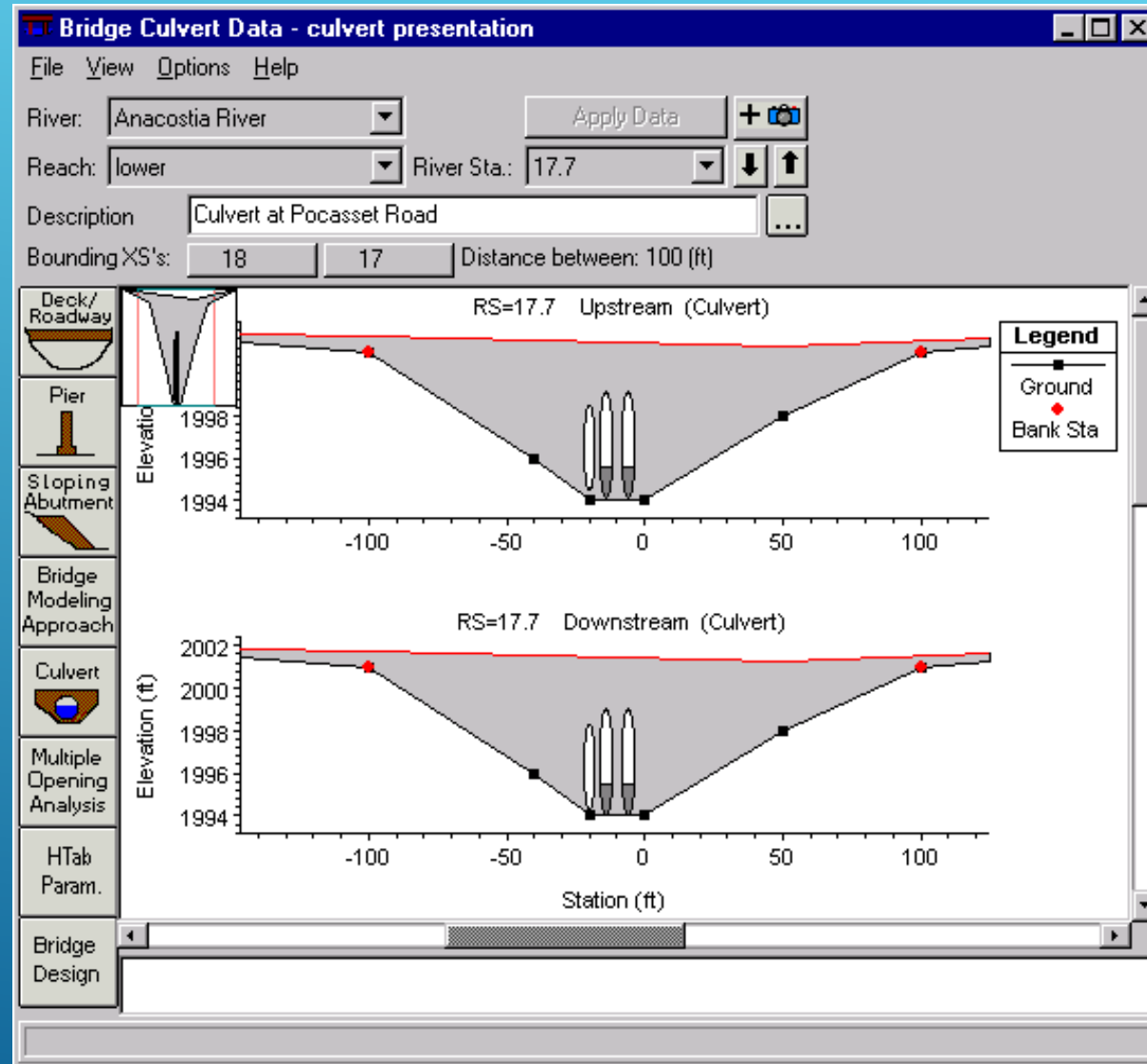

# ZOOM IN TO SEE XSEC LOCATIONS

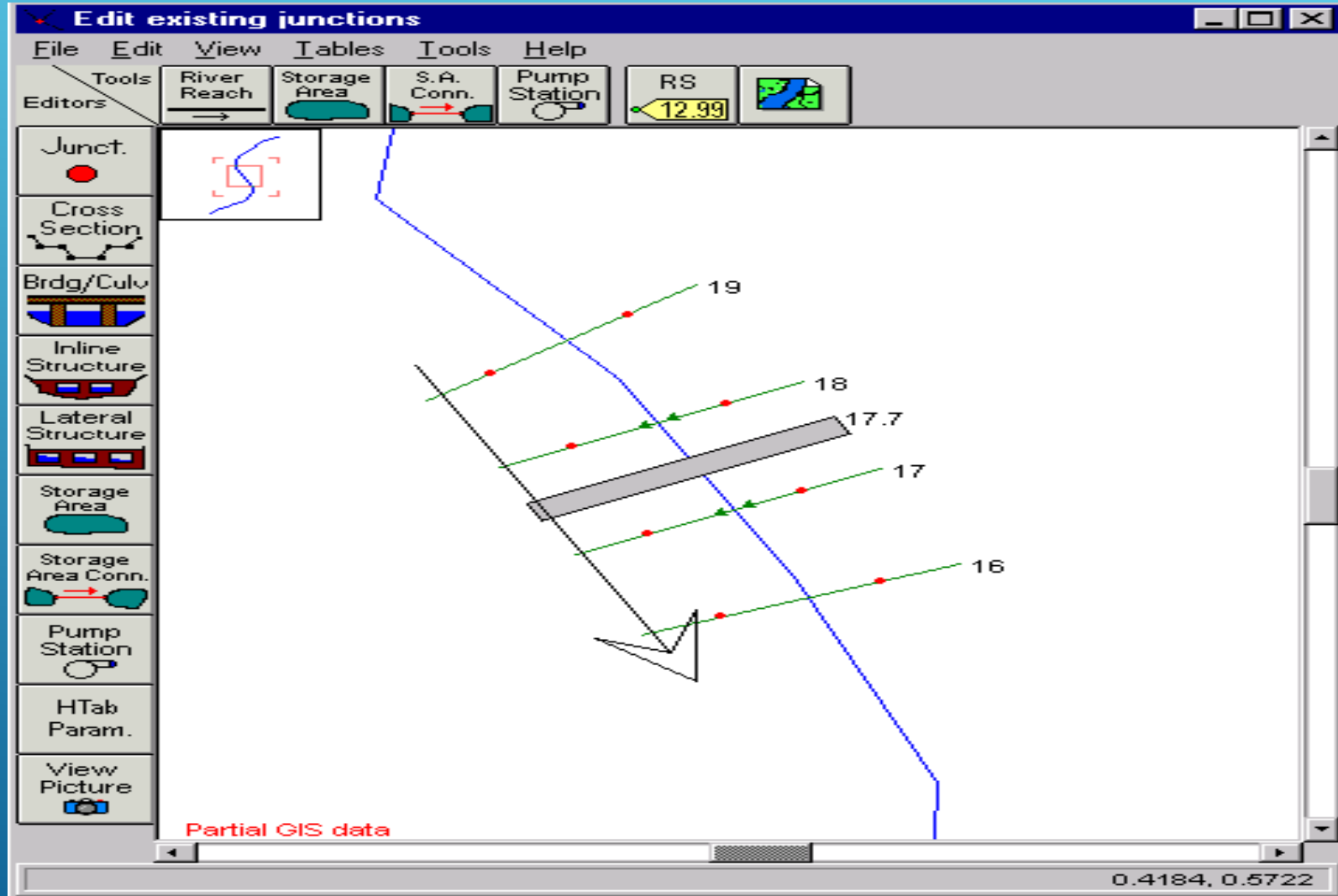

# ZOOM IN ON X-Y-Z PLOT

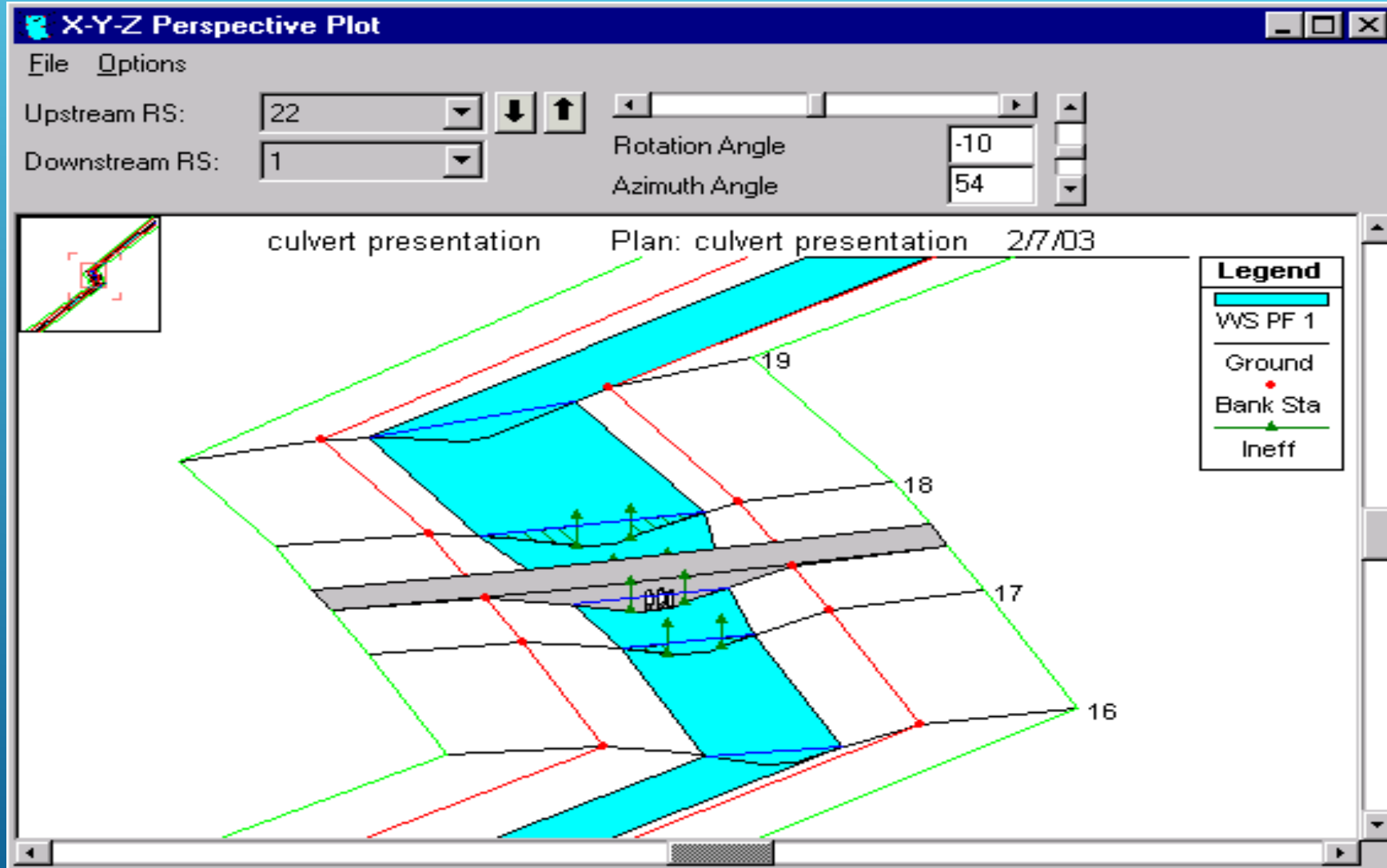

# MODELING INLINE STRUCTURES

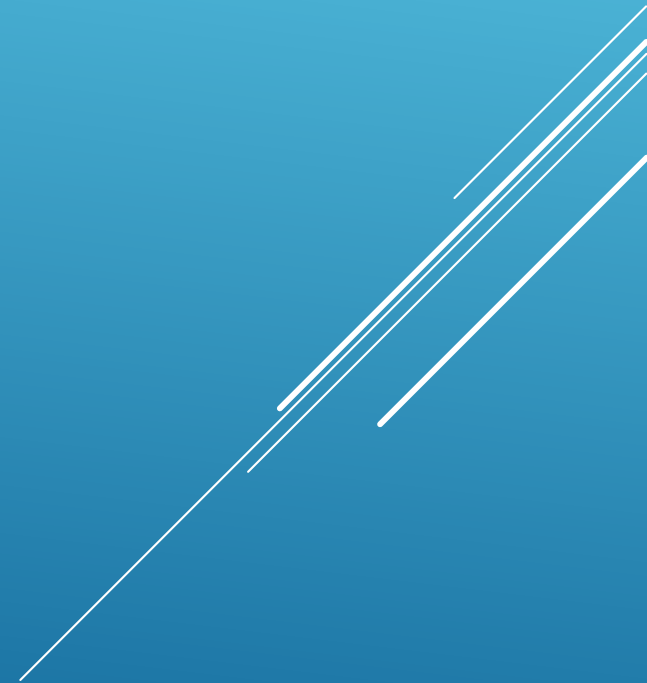

# IN LINE STRUCTURES

- ⌘ Can be used to model in-line gated spillways, overflow weirs, drop structures, and dams.
- ⌘ Modeling method is very similar to bridges and culverts.
- ⌘ Weir shapes are either ogee or broad crested.
- ⌘ Gates are either radial (tainter) or vertical lift (sluice).
- ⌘ Up to 10 groups of gates with up to 25 identical gates per group are allowed for each in line weir.
- ⌘ Identical gates must have same type, size, elevation, and coefficient.
- ⌘ Uncontrolled overflow area is also an option.

# IN LINE STRUCTURES

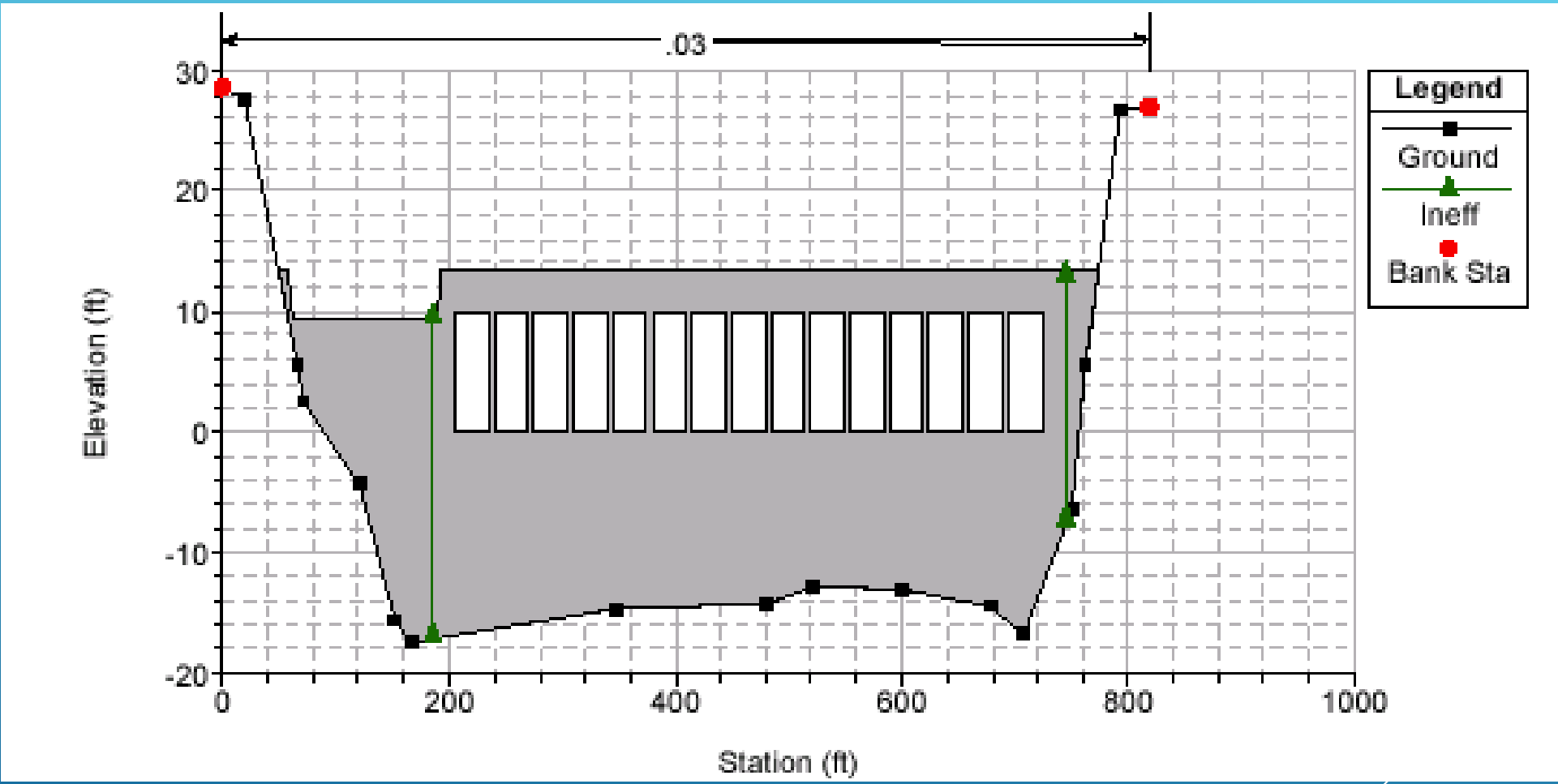

# CROSS-SECTION LOCATIONS

Suggested cross-section locations are the same as for bridges and culverts.

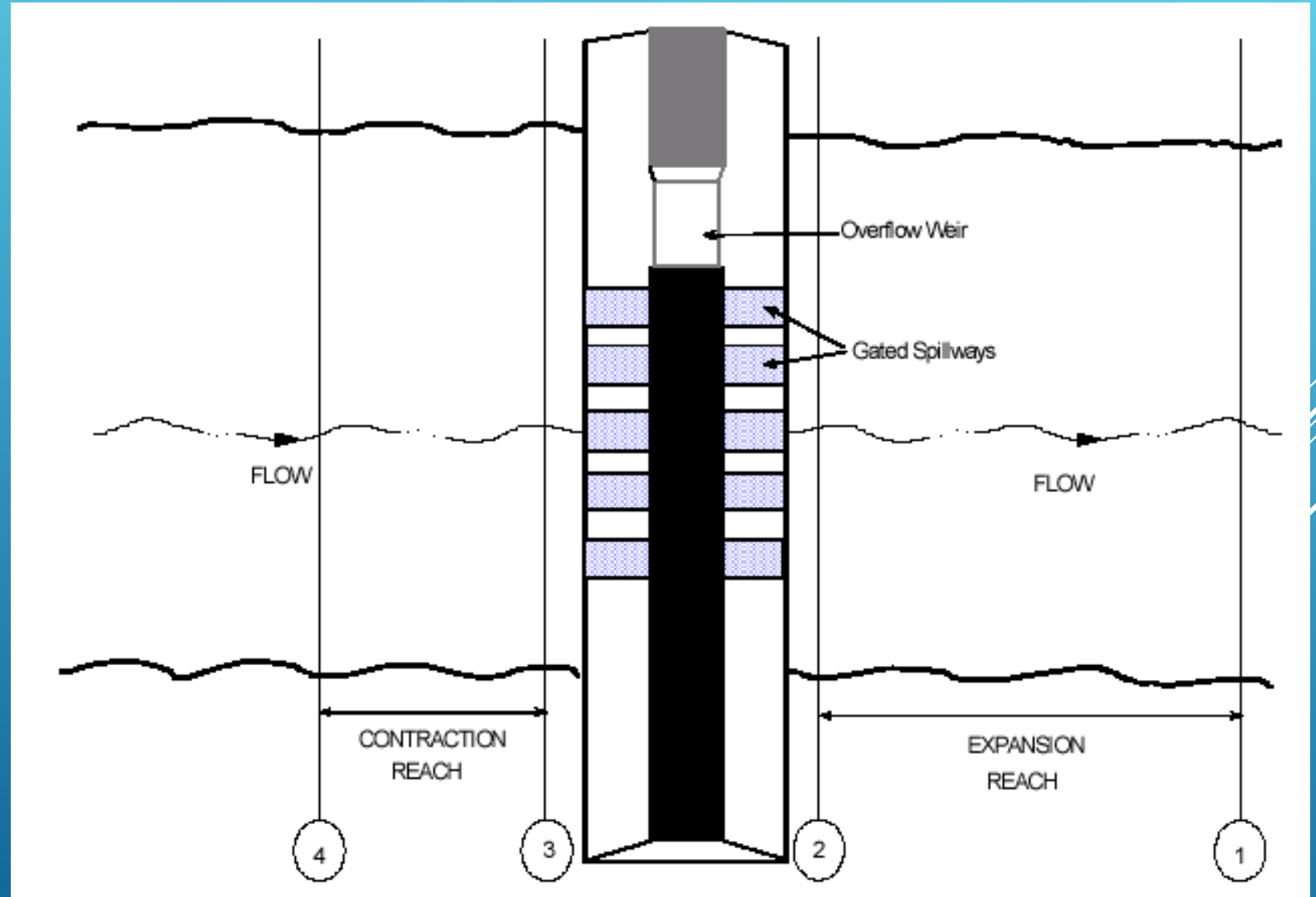

# IN LINE STRUCTURE

Brings up window similar to culvert and bridge windows.

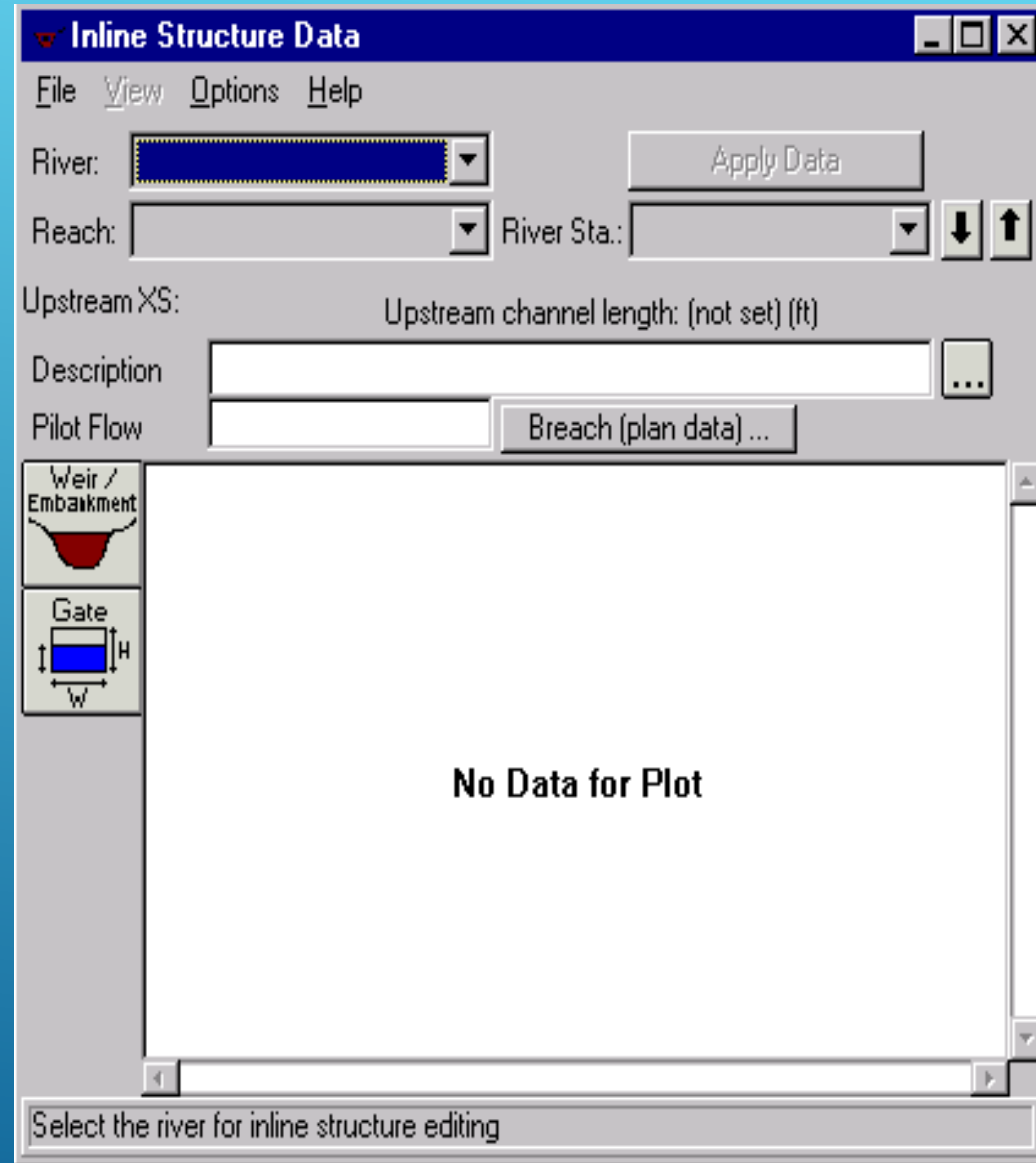

# IN LINE STRUCTURE

Must add structure as first step.

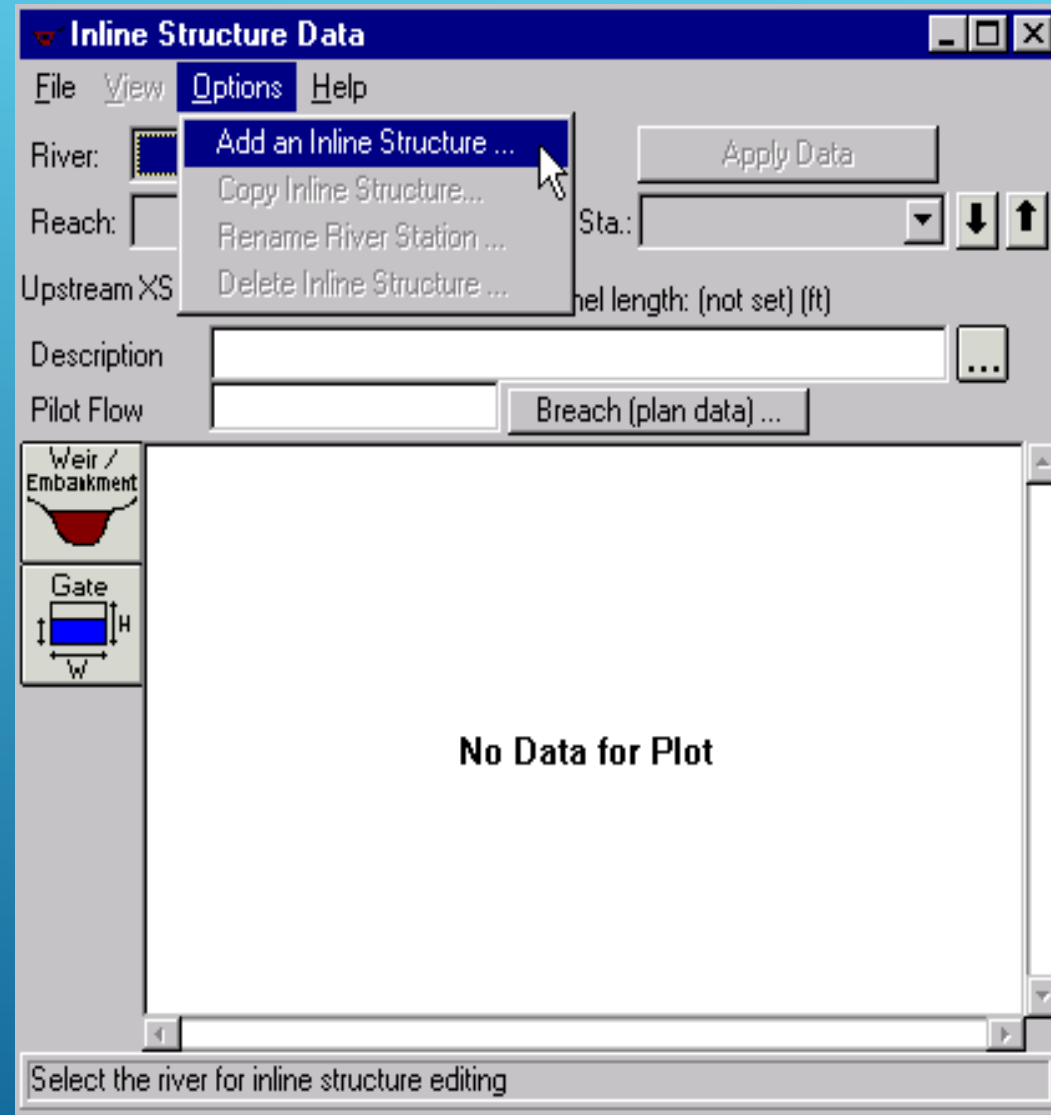

# IN LINE STRUCTURE

Brings up window to input cross-section location of the structure (weir)

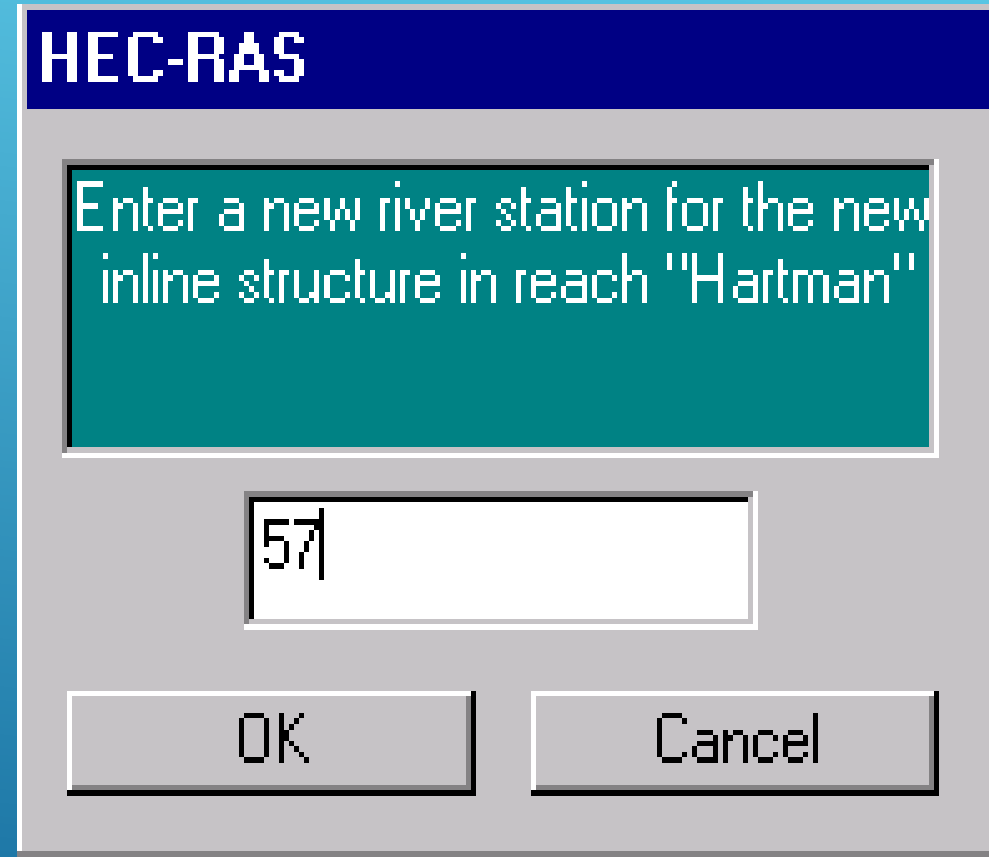

The image shows a screenshot of a dialog box from the HEC-RAS software. The dialog box has a dark blue title bar with the text "HEC-RAS" in white. Below the title bar is a green text area containing the instruction: "Enter a new river station for the new inline structure in reach 'Hartman'". Underneath the text area is a white text input field with the number "57" entered and a cursor at the end. At the bottom of the dialog box are two buttons: "OK" on the left and "Cancel" on the right.

# IN LINE STRUCTURE

Adds a plot of the upstream cross-section to the window.

Note you can edit the upstream cross-section from this button.

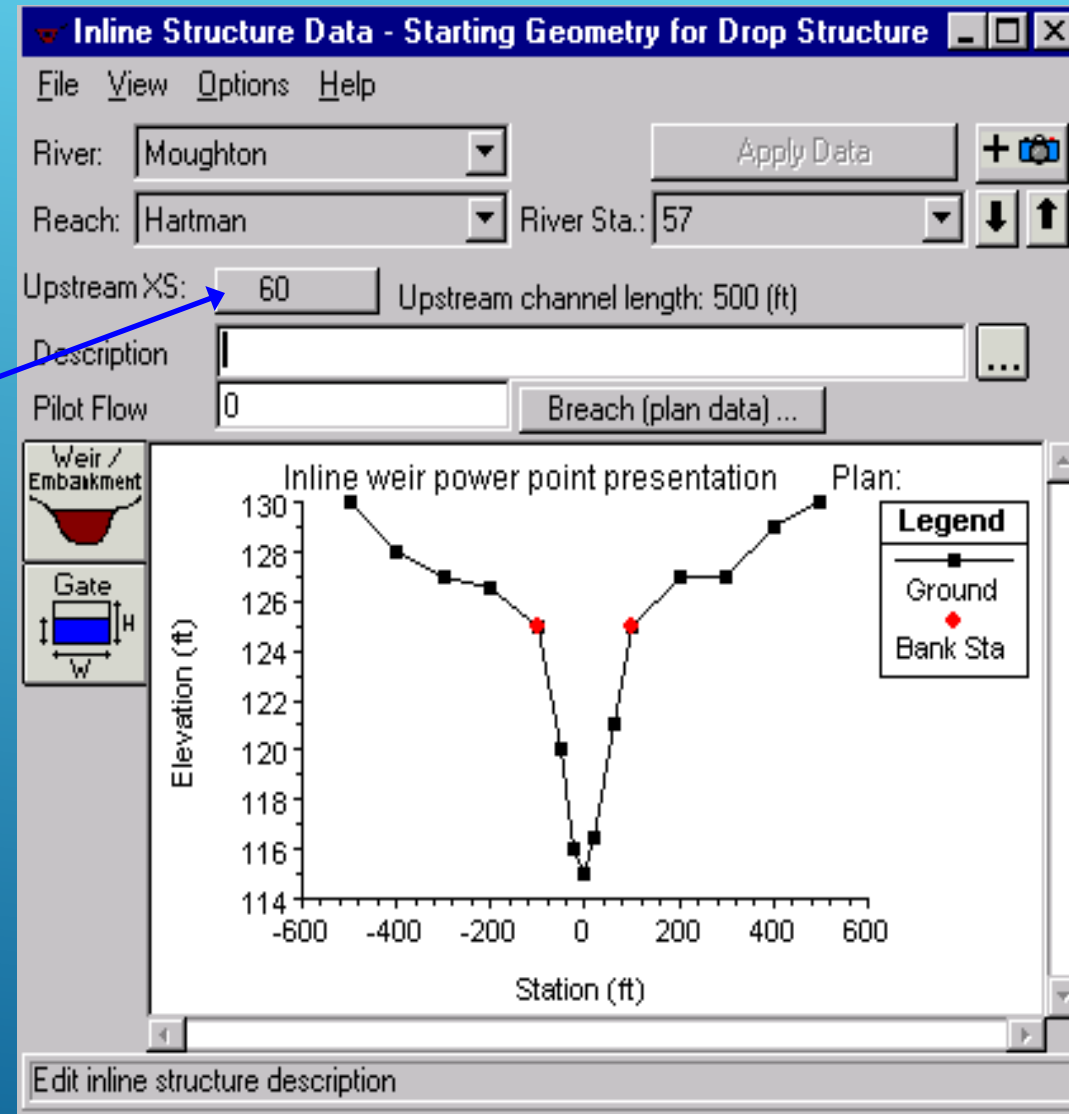

# IN LINE STRUCTURE

Click on the Weir/Embankment button...



**Inline Structure Weir Station Elevation Editor**

Del Row	Distance	Width	Weir Coef
Ins Row			2.6

Edit Station and Elevation coordinates

	Station	Elevation
1		
2		
3		
4		
5		
6		
7		
8		

U.S Embankment SS  D.S Embankment SS

**Weir Data**  
**Weir Crest Shape**  
 Broad Crested  
 Ogee

OK Cancel Clear

Enter distance between upstream cross section and deck/roadway. (ft)

Which brings up the Weir Editor Window

# IN LINE STRUCTURE

After filling in the data...

**Inline Structure Weir Station Elevation Editor**

Del Row		Distance	Width	Weir Coef
Ins Row		20	20	2.8

**Edit Station and Elevation coordinates**

	Station	Elevation
1	-500.	128.
2	-290.	128.
3	-290.	126.
4	-260.	126.
5	-260.	128.
6	500.	128.
7		
8		

U.S Embankment SS  D.S Embankment SS

**Weir Data**  
Weir Crest Shape  
 Broad Crested  
 Ogee

OK Cancel Clear

Enter distance between upstream cross section and deck/roadway. (ft)

# IN LINE STRUCTURE

... the plot is updated to show the embankment.

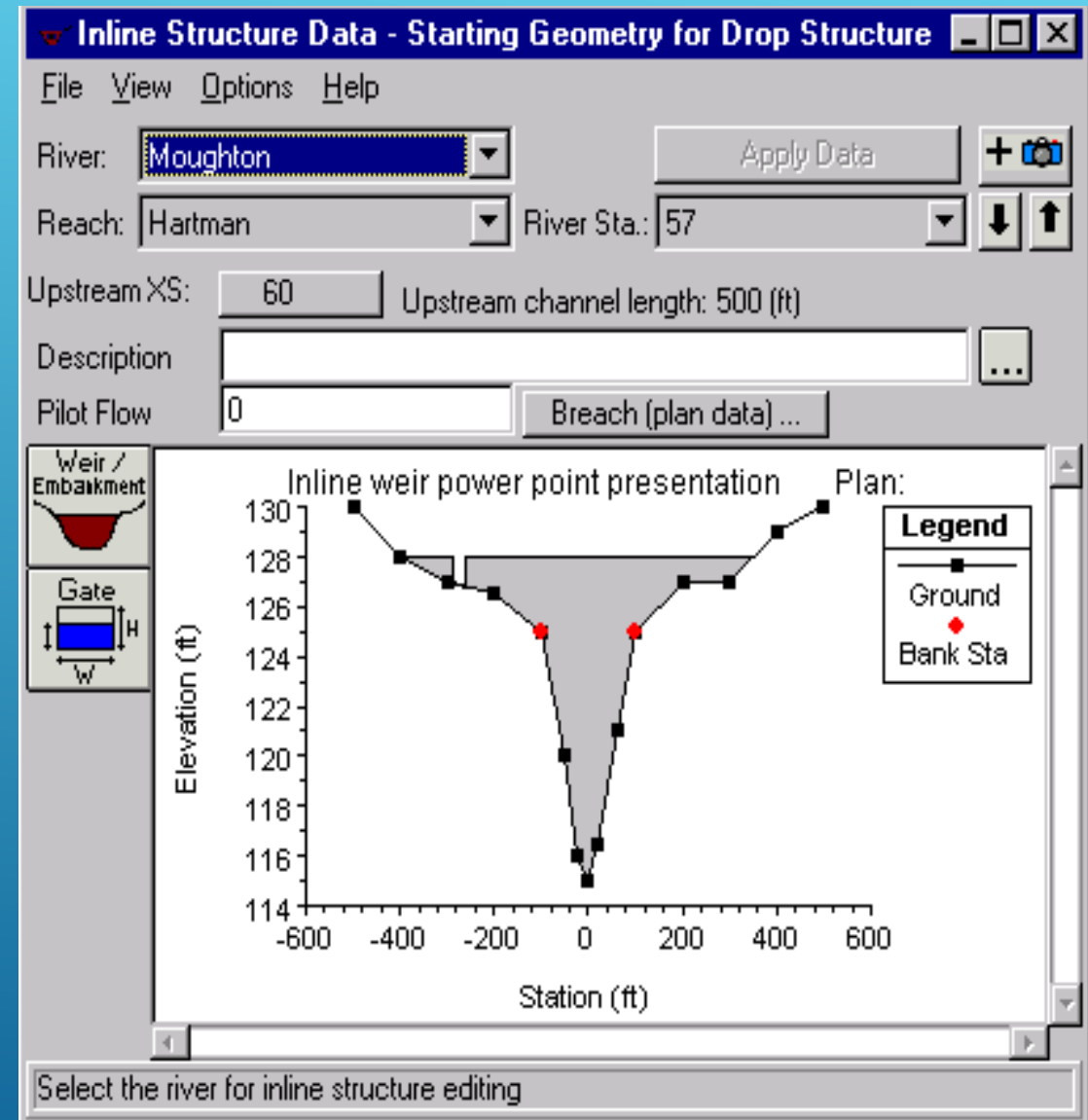

# IN LINE STRUCTURE

Click on the Gate button...

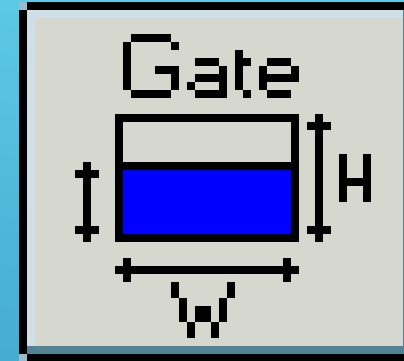

**Inline Gate Editor**

Gate Group: Gate #1

Height:  Width:  Invert:

Gate Data  
 Discharge Coefficient:

Gate Type: Sluice

Trunnion Exponent:

Opening Exponent:

Head Exponent:

Trunnion Height:

Orifice Coefficient:

Head Reference: Sill (Invert)

# Openings:

**Centerline Stations**

	Station
1	
2	
3	
4	
5	
6	
7	
8	

Weir Data  
 Weir Coefficient:

Weir Crest Shape  
 Broad Crested  
 Ogee

Edit the maximum height of the gate opening

Which brings up the Gate Editor Window

# IN LINE STRUCTURE

... the plot is updated showing the gates.

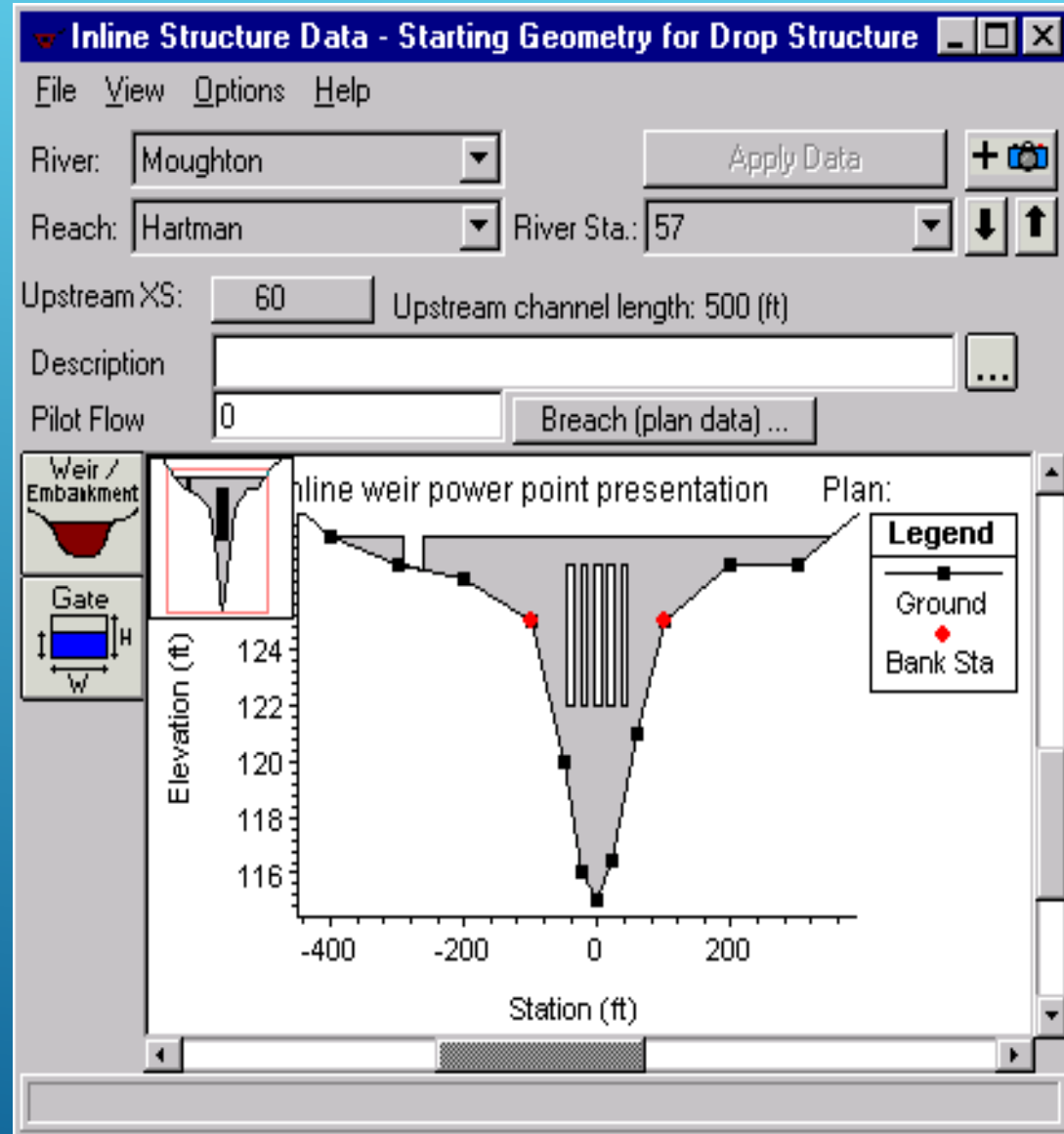

# OTHER FEATURES

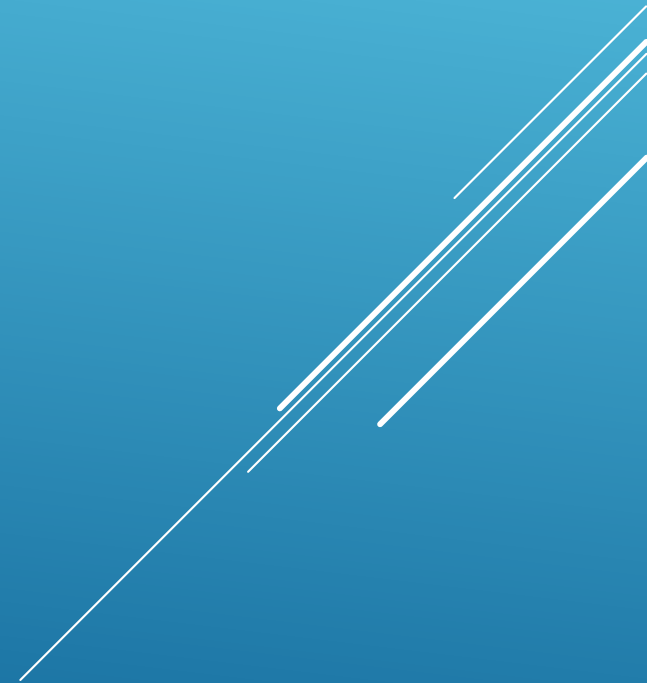

# OTHER FEATURES

- Horizontal variation in Manning's  $n$
- Vertical variation in Manning's  $n$
- Floodway encroachments
- Adding a lid to a cross section
- Graphical cross section editing
- Drop Structures
- Mixed flow
- Channel modifications



# HORIZONTAL VARIATION IN MANNING'S N

Useful where a cross section bisects a stand of trees or a large parking lot.

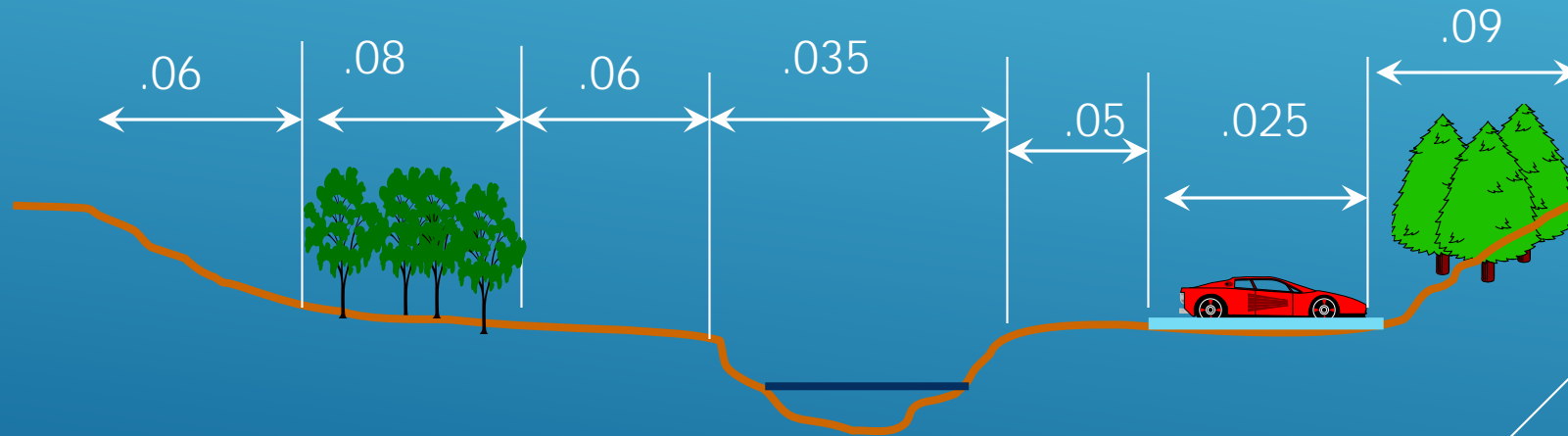

# HORIZONTAL VARIATION IN MANNING'S N

Under "Cross Section Data", click on "Options" then "Horizontal Variation in n Values"

**Section Data - min12**

Options Plot Help

Downstream Reach Lengths	
Channel	ROB
250	290

Manning's n Values	
Channel	ROB
0.03	0.05

Main Channel Bank Stations	
Left Bank	Right Bank
	1524.97

Cont/Exp Coefficients	
Contraction	Expansion
	0.3

Elevation (ft)

0 10 20 30 40 50 60

Riv

# HORIZONTAL VARIATION IN MANNING'S N

- An extra column will appear.
- A roughness value must be entered for the first ground point.
- HEC-RAS will apply this value for all points having a higher ground station until another is entered.
- Enter the roughness value for each different area.

The screenshot shows the 'Cross Section Data - min12' dialog box in HEC-RAS. It includes fields for River (NW Branch Anacos), Reach (Lower NW Branch), and River Sta. (4980). The main table displays cross-section data with columns for Station, Elevation, and n Val. The n Val column is highlighted, showing values for each station. The dialog also includes sections for Downstream Reach Lengths, Manning's n Values, Main Channel Bank Stations, and Cont/Exp Coefficients.

Del Row	Ins Row	Station	Elevation	n Val	
		1	1000	31.67	0.08
		2	1014	27.52	
		3	1027	19.9	.07
		4	1112	19.57	.05
		5	1165	19.81	
		6	1195	19.34	0.03
		7	1208	15.85	
		8	1232	10.61	
		9	1248	10.44	
		10	1271	9.39	

Downstream Reach Lengths

LOB	Channel	ROB
140	250	290

Manning's n Values

LOB	Channel	ROB
N/A	N/A	N/A

Main Channel Bank Stations

Left Bank	Right Bank
1195	1524.97

Cont/Exp Coefficients

Contraction	Expansion
0.1	0.3

Levee on right side

Edit Station Elevation Data (ft)

# VERTICAL VARIATION IN MANNING'S N

- Can be used to reflect hydraulic changes that vary by either elevation or flow
- Allows the user to vary Manning's n both vertically as well as horizontally

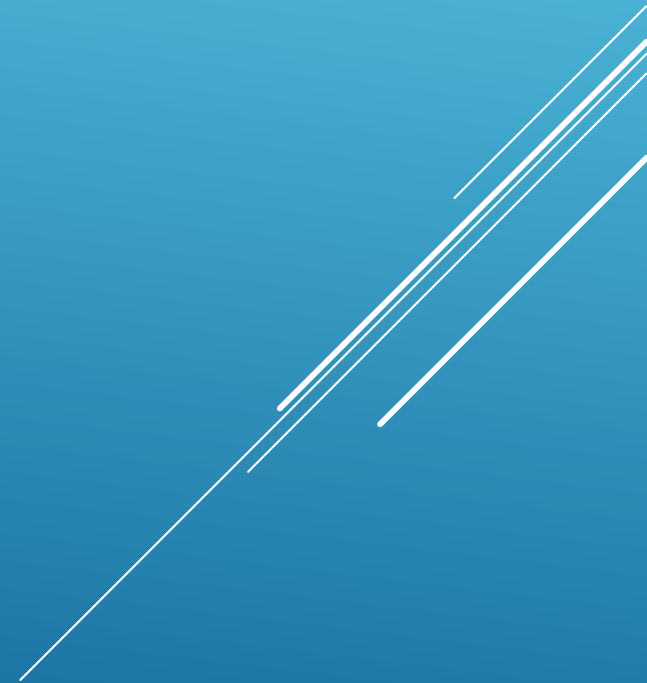

# GRAPHICAL CROSS SECTION EDITING

Available under “Tools” menu from Geometric Data Editor.  
Allows user to:

- Add, move, and delete points
- Add normal ineffective flow areas
- Add blocked ineffective flow areas
- Add normal blocked obstructions
- Add multiple blocked obstructions
- Add levees

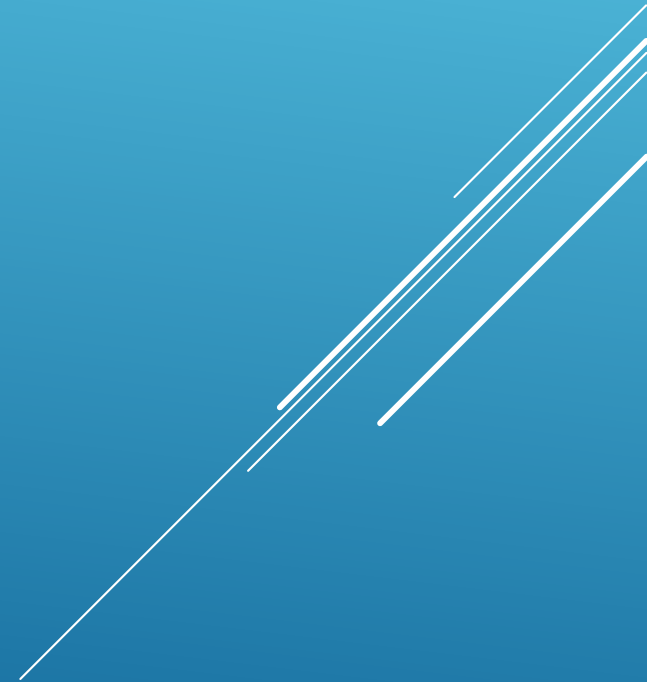

# CROSS-SECTION INTERPOLATION

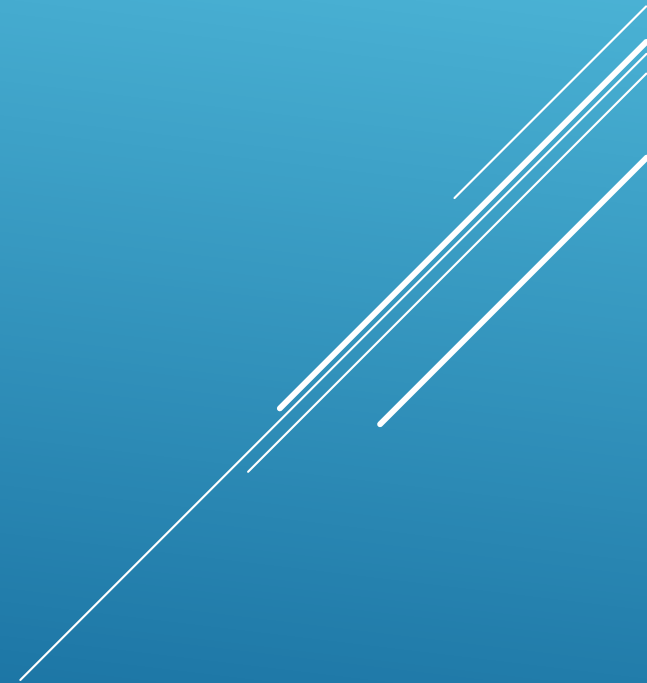

# CROSS SECTION INTERPOLATION

- ▶ Sometimes it is necessary to supplement surveyed cross section data by interpolating new sections between two surveyed sections
- ▶ Typically needed when the change in velocity head is large. HECRAS detects this by comparing conveyance values between two sections.



Geometric interpolation is accomplished by linearly interpolating between elevations and stations along “cords”

2 Options -

- ➔ Interpolate a reach (more than 2 cross-sections)
- ➔ Between 2 cross-sections

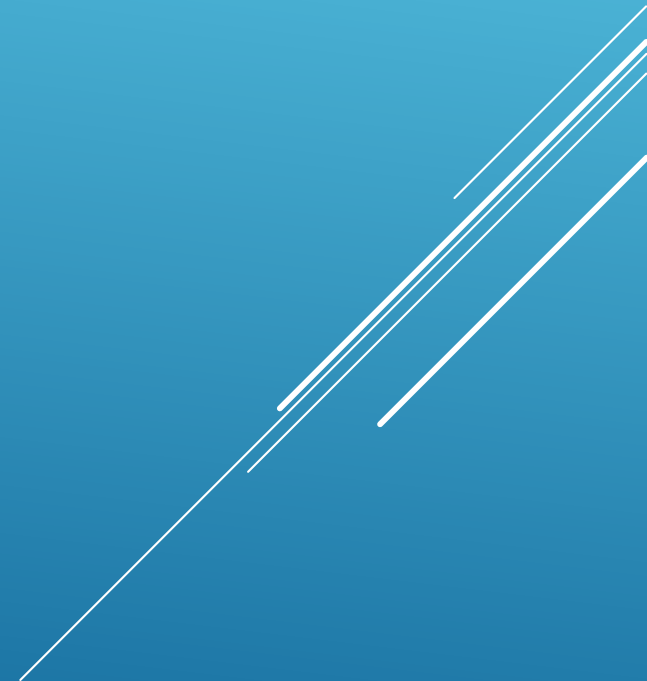

Geometric Data - Exercise No. 1

File Edit View Tables Tools Help

Tools River Reach Storage Area

Editors

- Junct.
- Cross Section
- Brdg/Culv
- Inline Structure
- Lateral Structure
- Storage Area
- Storage Area Conn.
- Pump Station
- HTab Param.
- View Picture

XS Interpolation

- Channel Modification ...
- Graphical Cross Section Edit ...
- Reverse Stationing Data ...
- Set Ineffective Areas to Permanent Mode...
- Cross Section Points Filter ...
- Fixed Sediment Elevations ...
- Pilot Channels ...
- GIS Cut Line Check ...
- View Reach Connectivity ...
- Datum Adjustment ...
- Fix Overlapping Ineffective Areas ...
- GIS Coordinates

Within a Reach ...

Between 2 XS's ...

Plot GIS Profile Reach Bounds ...

Reach Order for Computations ...

Reach Order --> Find Loops ...

Flow Roughness Factors ...

Seasonal Roughness Factors ...

Design Cross Sections ...

0.1911, 0.9897

# CROSS SECTION INTERPOLATION MASTER CORDS

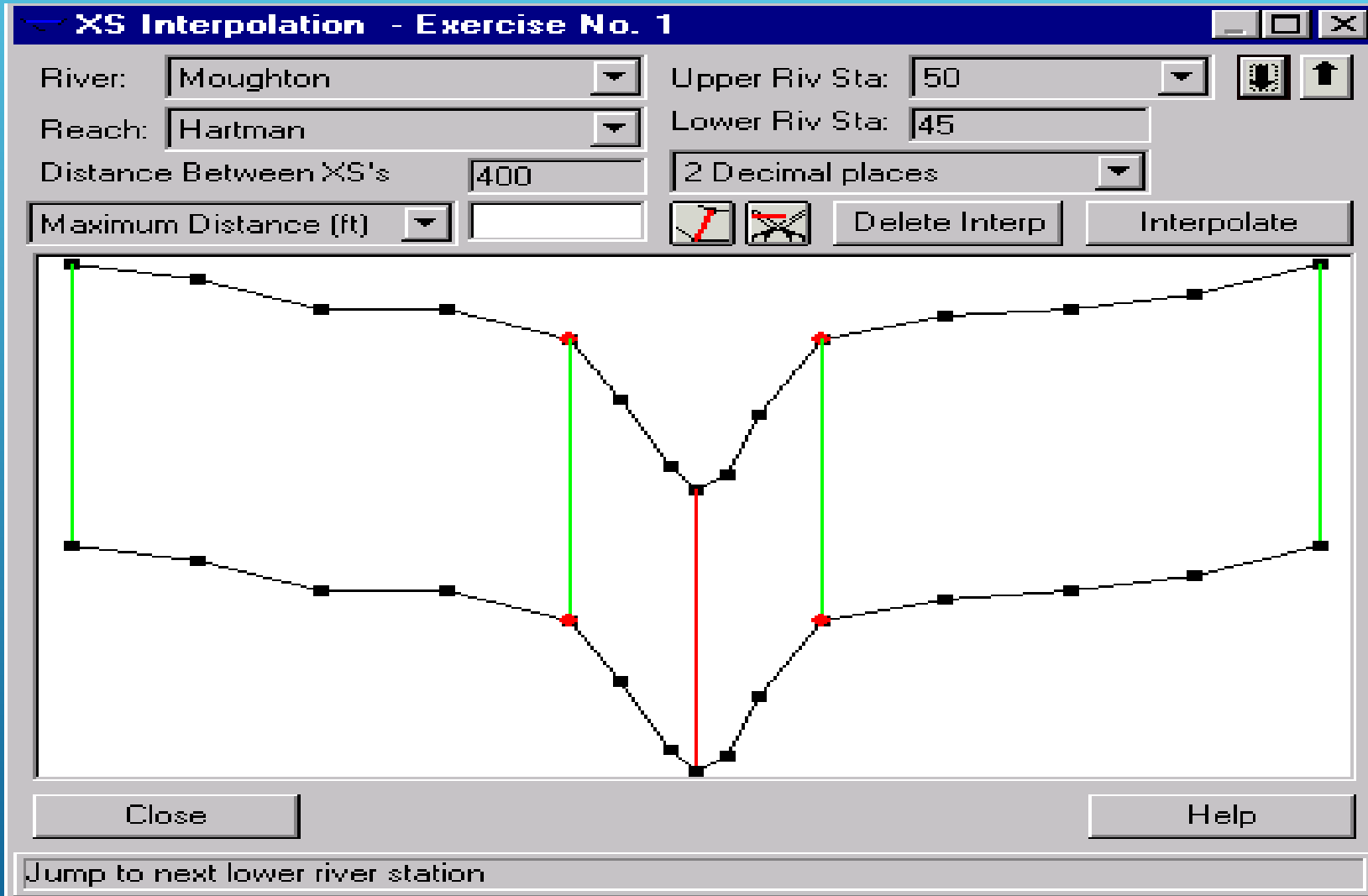

# ADDING MASTER CHORDS TO INTERPOLATION

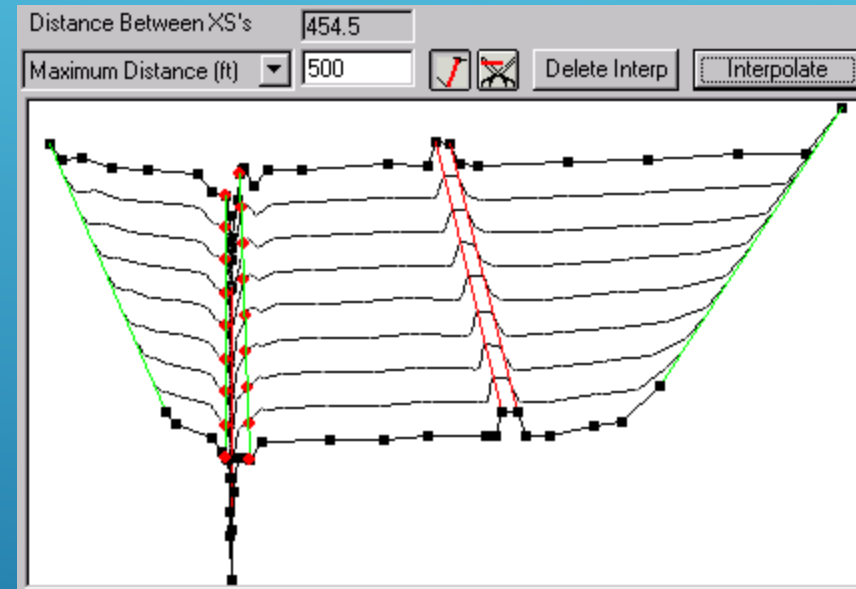
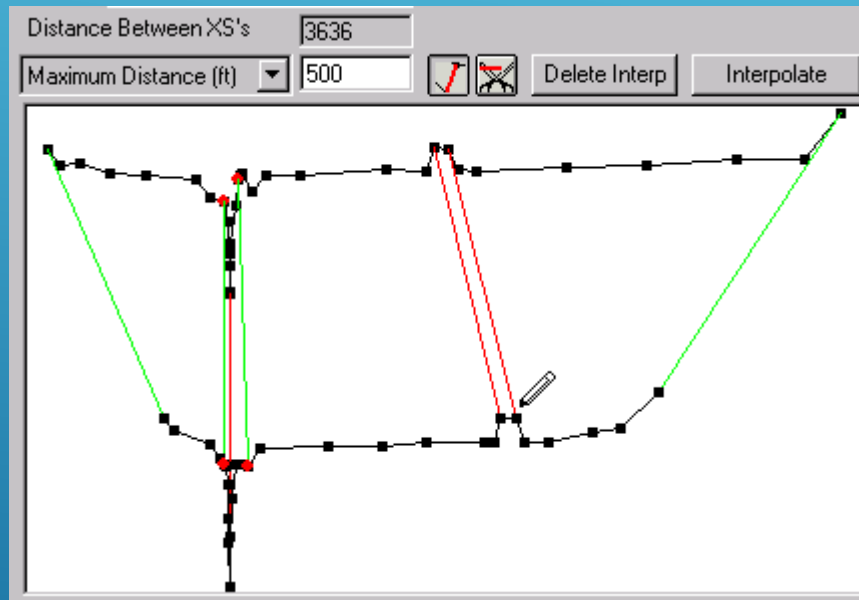

# CROSS SECTION INTERPOLATION MINOR CORDS

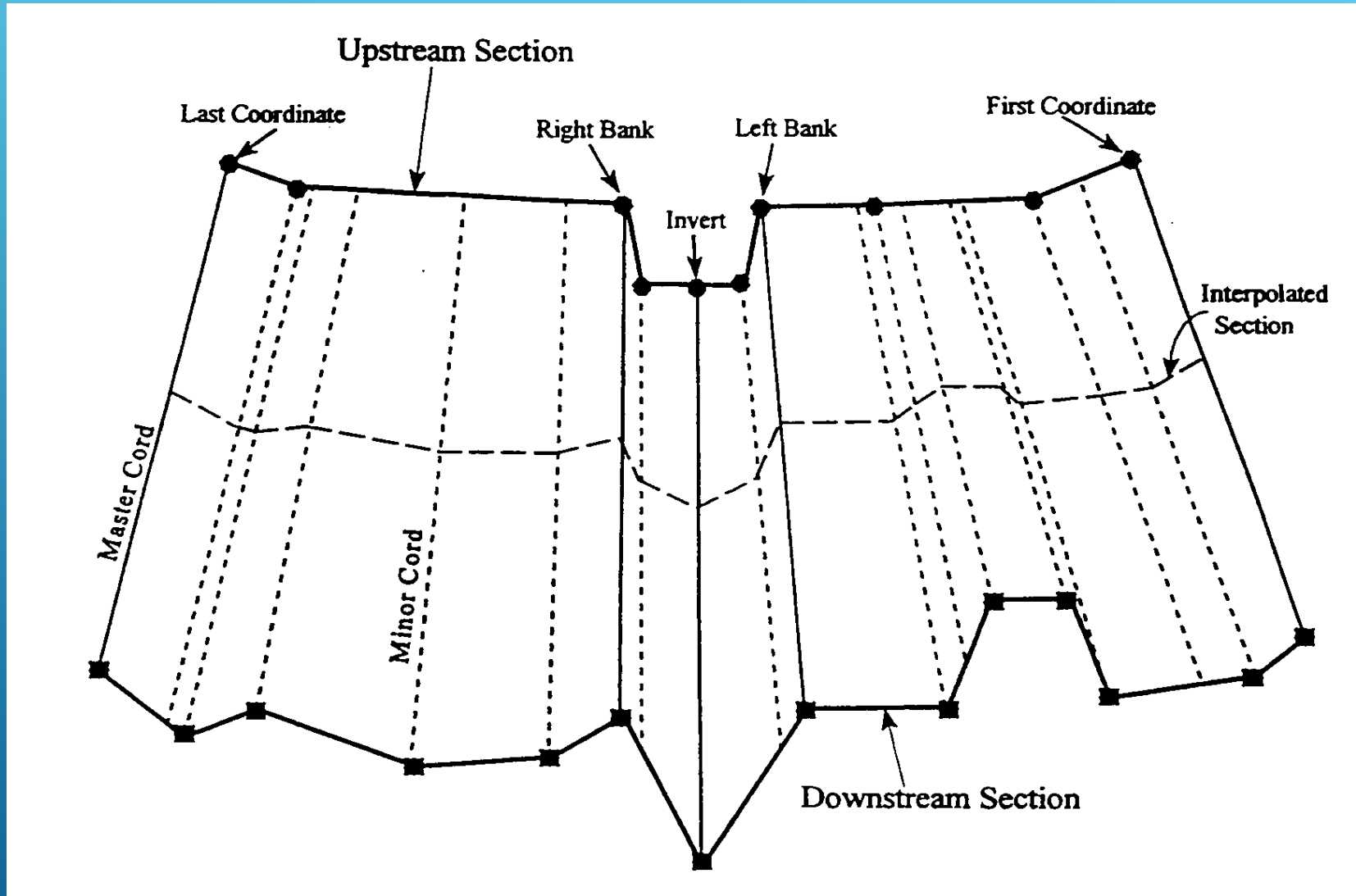

# CROSS SECTION INTERPOLATION MINOR CORDS

- ▶ Automatically generated by program
- ▶ Stations are determined using proportional distances between master cords
- ▶ Number of minor cords = sum of coordinates in bounding cross sections minus number of master cords

# CROSS SECTION INTERPOLATION

## OTHER

- ▶ Other features which are interpolated: downstream reach lengths, main channel bank stations, contraction and expansion coefficients, normal ineffective flow areas, levees, and normal blocked obstructions
- ▶ Normal ineffective flow areas, levees, and normal blocked obstructions are interpolated only if both bounding cross sections have them.
- ▶ Can interpolate between 2 cross sections or entire reach

# UNSTEADY FLOW

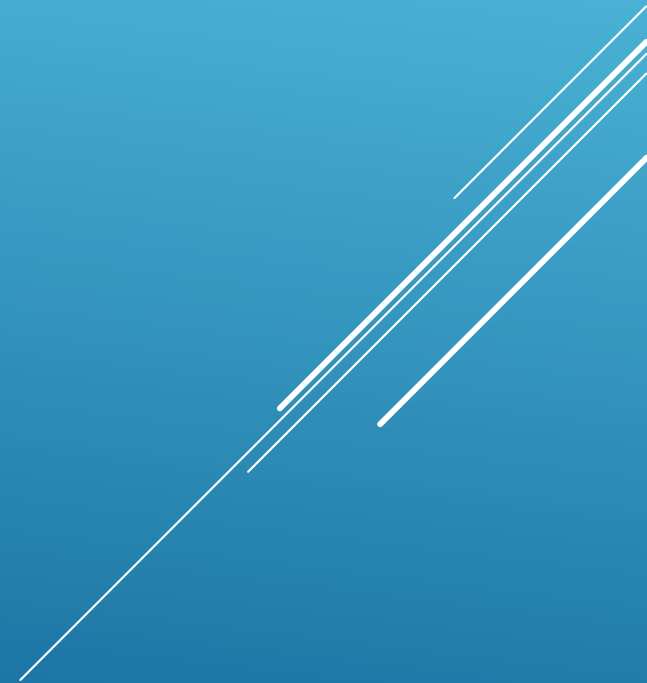

# WHEN TO USE UNSTEADY FLOW

- ▶ Tidal/estuary fluctuation
- ▶ Off-channel storage
- ▶ Dam breach routing
- ▶ Channels with flat slopes
- ▶ Levee overtopping
- ▶ Hydraulic structures affected by changing backwater
- ▶ Large amounts of storage behind roads or culverts

# STEADY VS. UNSTEADY

- ▶ Difference in handling boundary friction and other losses
  - ▶ Difference in numerical solution algorithm
  - ▶ Difference in handling non-flow areas
  - ▶ Difference in flow and boundary condition data requirements
  - ▶ Difference in calibration strategy
  - ▶ Difference in application strategy
- 
- A decorative graphic consisting of several parallel white lines of varying lengths, slanted diagonally from the bottom right towards the top right, set against the blue background.

# PRE-COMPUTATION OF HYDRAULIC PROPERTIES

**Steady** – Compute exact hydraulic properties at a section for each trial water surface elevation from the elevation/station points,  $n$ -values.

**Unsteady** – Hydraulic properties are pre-computed for all possible water surface elevations at each cross section (hydraulic table)

# DATA REQUIREMENTS (FLOW AND BOUNDARY CONDITIONS)

**Steady:** Discharge ( $Q$ ) at each cross section.

**Unsteady:** Inflow hydrograph(s) which are routed by the model.

# UNSTEADY FLOW DATA

- ▶ External Boundaries required
  - ▶ Upstream and Downstream ends of the river
  - ▶ Typically flow or stage hydrograph upstream
  - ▶ Typically rating or “normal depth” downstream
- ▶ Internal Boundaries can be added
  - ▶ Add flow within the river system
  - ▶ Define gate operation
- ▶ Initial Conditions - at the start of simulation

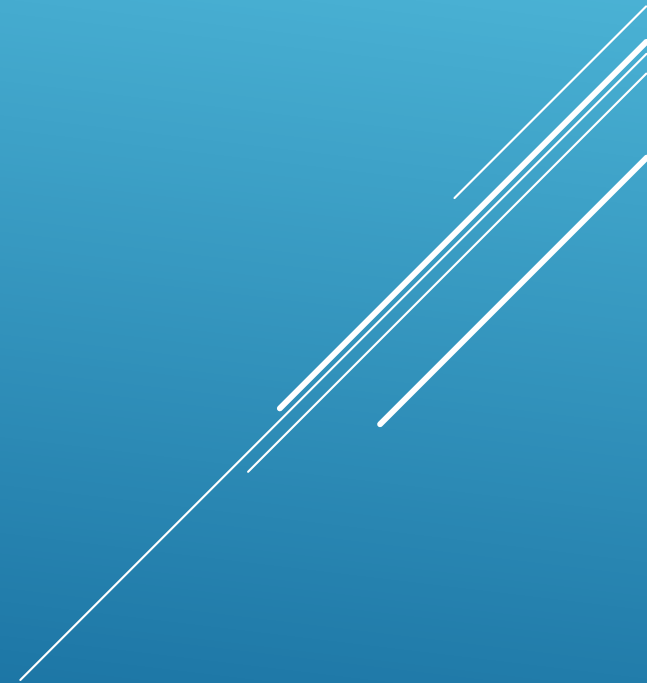

# UNSTEADY FLOW DATA EDITOR

**HEC-RAS - River Analysis System**

File Edit Run View Options Help

Project: Beaver Creek Geometric Data  
 Plan: Beaver Creek near Kentwood  
 Geometry: Beaver Creek near Kentwood  
 Steady Flow:   
 Unsteady Flow: Unsteady Flow  
 Project Description :

**Unsteady Flow Data - Unsteady Flow**

File Options Help

Boundary Conditions Initial Conditions Apply Data

Select Location for Boundary Condition

River: Beaver Creek  
 Reach: Kentwood River Sta.: 5.99 Add a Boundary Condition Location

Boundary Condition Types

Stage Hydrograph	Flow Hydrograph	Stage/Flow Hydr.	Rating Curve
Normal Depth	Lateral Inflow Hydr.	Uniform Lateral Inflow	Groundwater Interflow
T.S. Gate Openings	Elev Controlled Gates	Navigation Dams	Intern. Obs. Stage/Flow

	River	Reach	RS	Boundary Condition Type
1	Beaver Creek	Kentwood	5.99	
2	Beaver Creek	Kentwood	5.0	

Storage Area and SA Connections: Add a Boundary Condition Location

	Storage Area or SA Connection	Boundary Condition Type
1		

# BOUNDARY CONDITIONS

- ▶ Editor shows required external boundaries
- ▶ Boundary Type shows available options
- ▶ Upstream options:
  - ▶ Stage Hydrograph
  - ▶ Flow Hydrograph
  - ▶ Stage & Flow Hydrograph

Boundary Conditions | Initial Conditions | Apply Data

Select Location for Boundary Condition

River: Beaver Creek

Reach: Kentwood River Sta.: 5.99 Add a Boundary Condition Location

Boundary Condition Types

Stage Hydrograph	Flow Hydrograph	Stage/Flow Hydr.	Rating Curve
Normal Depth	Lateral Inflow Hydr.	Uniform Lateral Inflow	Groundwater Interflow
T.S. Gate Openings	Elev Controlled Gates	Navigation Dams	Intern. Obs. Stage/Flow

River	Reach	RS	Boundary Condition Type
1 Beaver Creek	Kentwood	5.99	
2 Beaver Creek	Kentwood	5.0	

# BOUNDARY CONDITIONS - CONTINUED

- ▶ Downstream Boundary Options:
  - ▶ Stage Hydrograph
  - ▶ Flow Hydrograph
  - ▶ Stage & Flow Hydrograph
  - ▶ Rating Curve
  - ▶ Normal Depth

Boundary Conditions
Initial Conditions
Apply Data

Select Location for Boundary Condition

River: 
 Reach: 
 River Sta.:

Boundary Condition Types

Stage Hydrograph	Flow Hydrograph	Stage/Flow Hydr.	Rating Curve
Normal Depth	Lateral Inflow Hydr.	Uniform Lateral Inflow	Groundwater Interflow
T.S. Gate Openings	Elev Controlled Gates	Navigation Dams	Intern. Obs. Stage/Flow

	River	Reach	RS	Boundary Condition Type
1	Beaver Creek	Kentwood	5.99	
2	Beaver Creek	Kentwood	5.0	

# NORMAL DEPTH

- ▶ Enter Friction (energy) Slope
- ▶ Program uses Manning's equation to compute stage
- ▶ Provides semi-dynamic downstream boundary

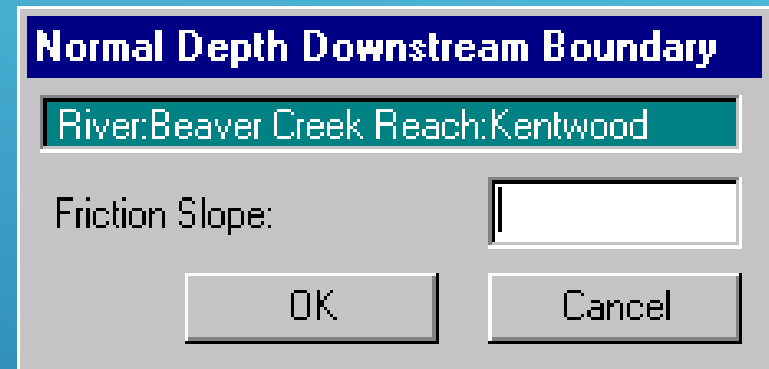

**Normal Depth Downstream Boundary**

River:Beaver Creek Reach:Kentwood

Friction Slope:

OK Cancel

# UNSTEADY FLOW SIMULATION SIMULATION MANAGER

1. Define a Plan



2. Select which  
programs to run



3. Enter a starting and  
ending date and time



4. Set the computation  
settings



5. Press the Compute  
button

The screenshot shows the 'Unsteady Flow Analysis' dialog box with the following fields and settings:

- Plan:** Beaver Creek Near Kentwood
- Short ID:** Beaver Cr.
- Geometry File:** Beaver Cr.
- Unsteady Flow File:** Unsteady Flow
- Programs to Run:**
  - Geometry Preprocessor
  - Unsteady Flow Simulation
  - Post Processor
- Simulation Time Window:**
  - Starting Date:** 5/22/1974
  - Ending Date:** 5/24/1974
  - Starting Time:** 0000
  - Ending Time:** 2400
- Computation Settings:**
  - Computation Interval:** 1 Minute
  - Hydrograph Output Interval:** 1 Hour
  - Detailed Output Interval:** 2 Hour
- DSS Output Filename:** C:\HECRAS\_31\Workshops\BeaverSA.dss
- Mixed Flow Regime (see menu: "Options/Mixed Flow Options ...")
- Compute** button

# OUTPUT SELECTION

- ▶ Unsteady Flow Output
  - ▶ Stage and Flow Hydrographs
  - ▶ Log File Output
- ▶ Post Processor
  - ▶ Detailed output
    - ▶ Max Stage
    - ▶ Selected Time Intervals

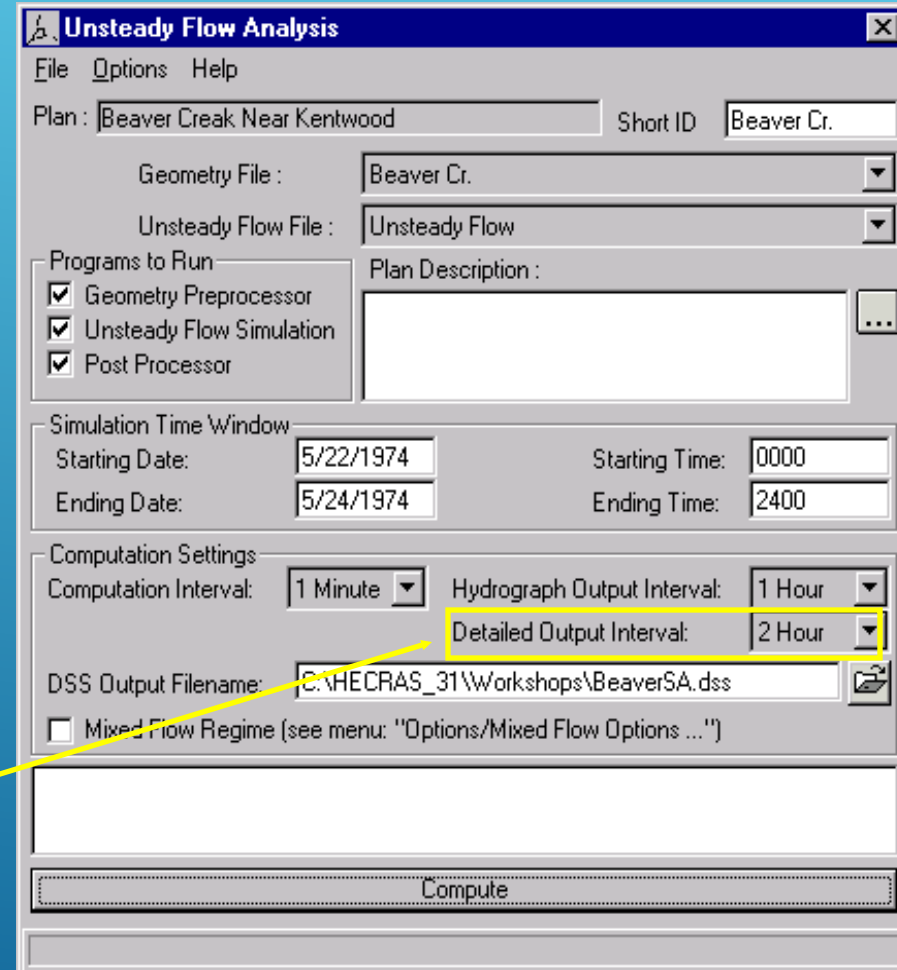

# VIEWING UNSTEADY FLOW RESULTS

- ▶ All of the output that was available for steady flow computations is available for unsteady flow (cross sections, profile, and 3D plots and tables).
- ▶ Stage and flow hydrographs
- ▶ Time series tables
- ▶ Animation of cross section, profile and 3-dimensional graphic

# STAGE AND FLOW PLOT

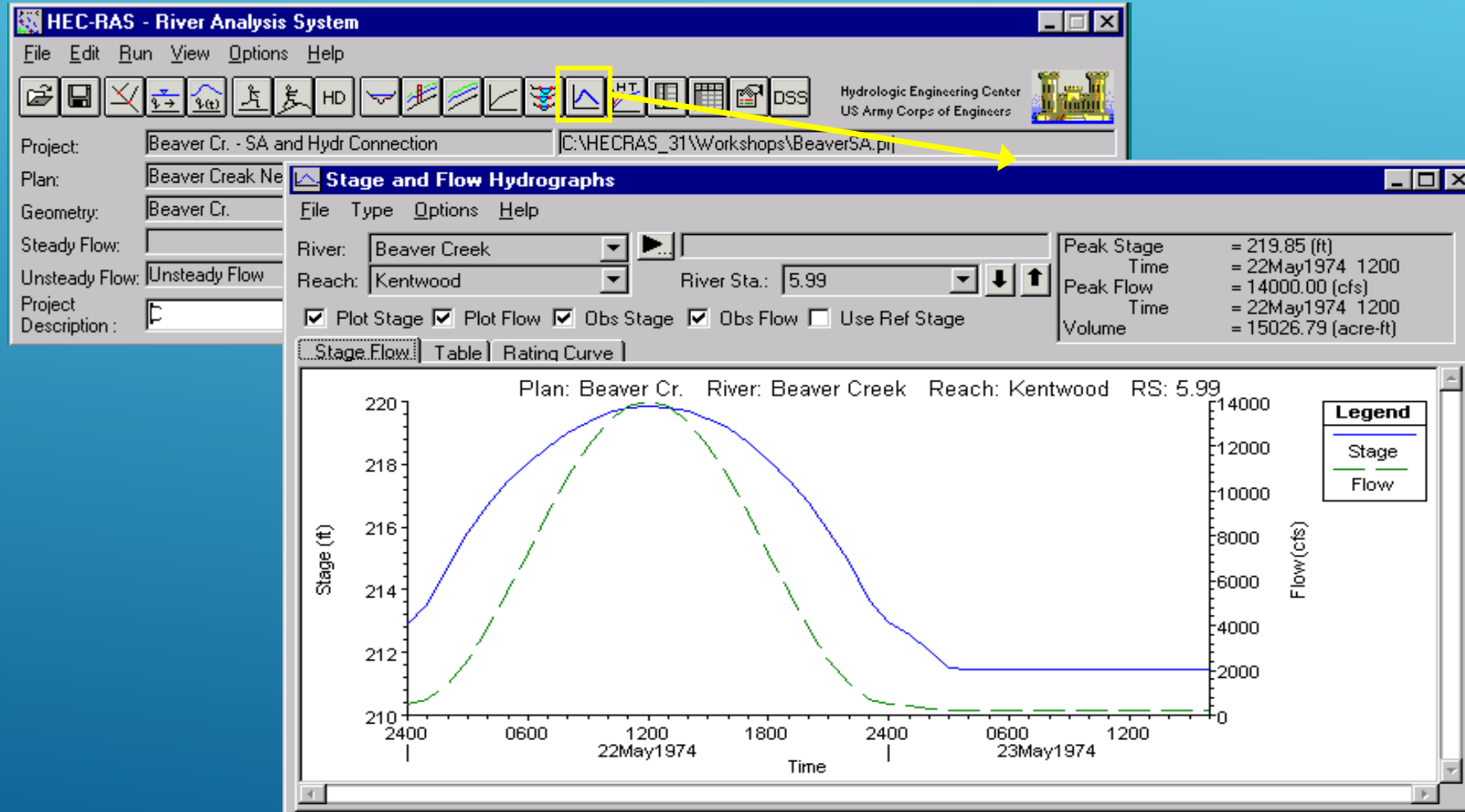

# UNSTEADY FLOW RATING CURVE

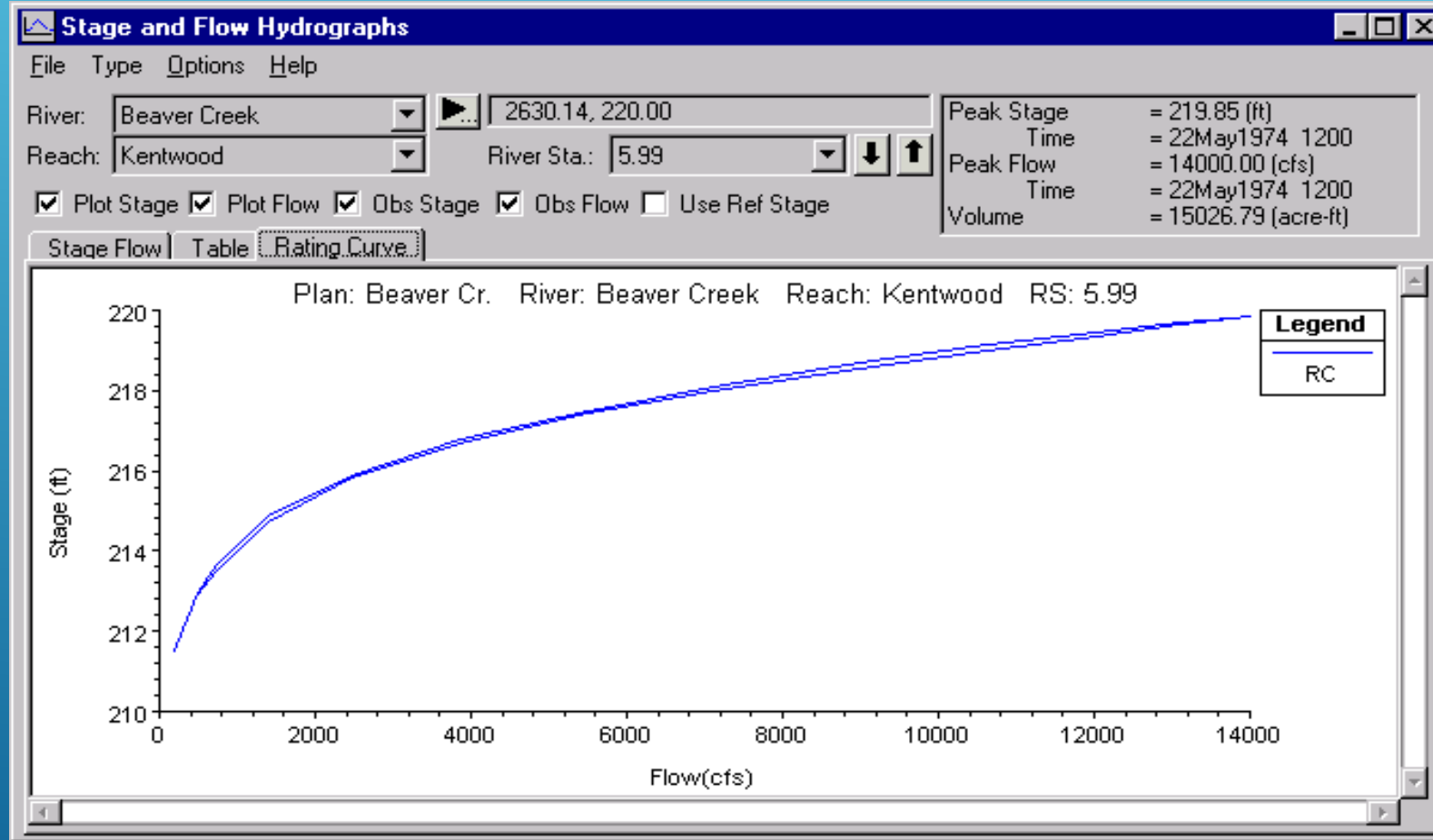

# PROFILE ANIMATION

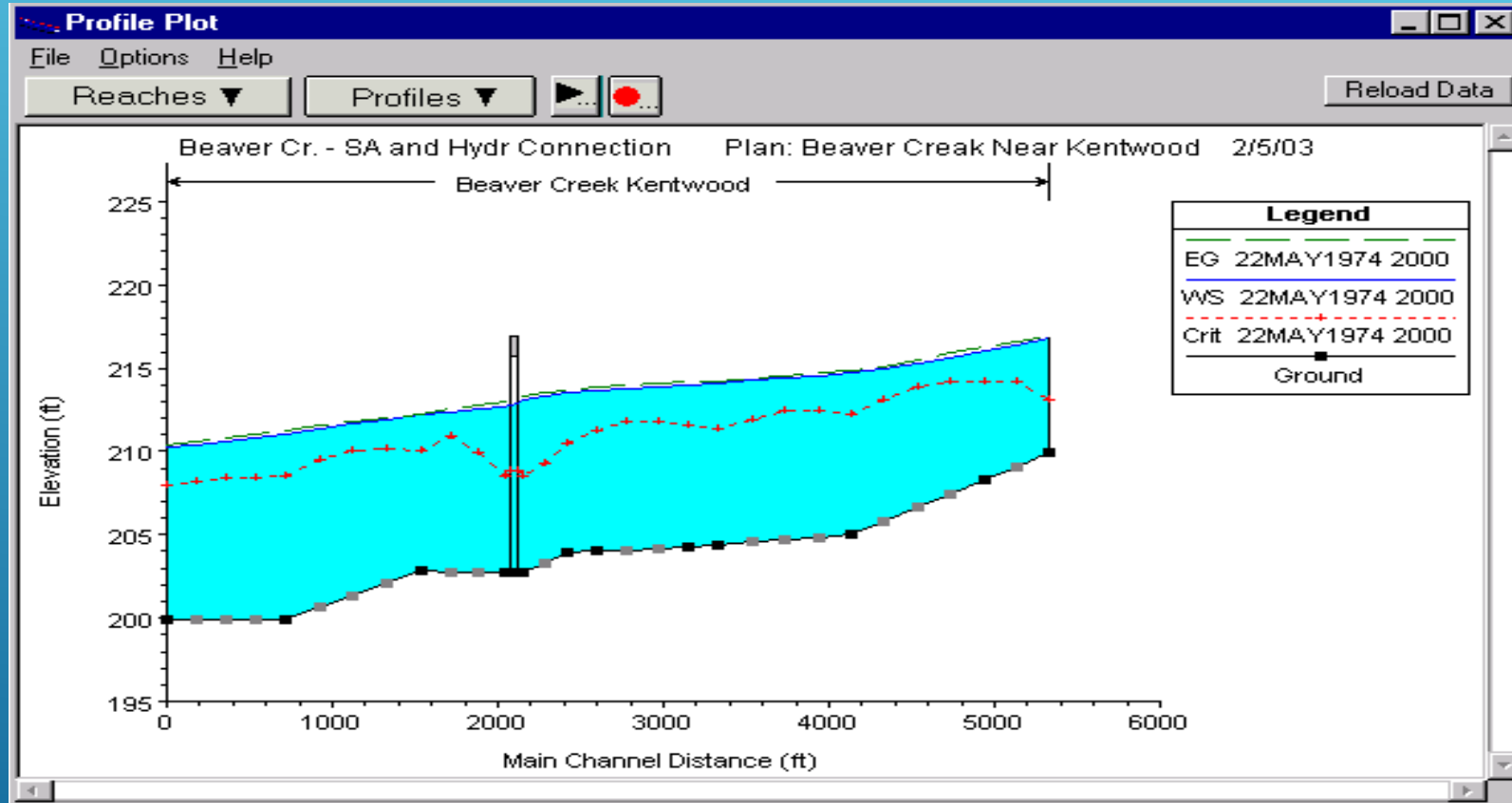



# MODEL IMPLEMENTATION – 2D

# INDEX – MODEL BUILD 2D

1. CREATING THE PROJECT FILE
2. DEFINE THE PROJECT PROJECTION
3. IMPORT THE TERRAIN
4. IMPORT THE LAND COVER
5. DEFINE GEOMETRY FILE
6. DEFINE THE BOUNDARY CONDITIONS
7. RUN THE MODEL
8. EXAMINE THE RESULTS



# HINTS AND RECOMMENDATIONS

## Hints and recommendations in 2D applications

- ▶ For all 2D applications the most important input parameter is the bathymetry (or DEM or topography).
- ▶ The second most important set of parameters are the forcing specifications (boundaries, rainfall, evaporation, etc.)
- ▶ Followed finally by the traditional calibration parameters like eddy viscosity and bed friction.



# BOUNDARIES

- ▶ The location of model boundaries is an important consideration in the development of a model domain. Model boundaries should be located so as to minimise the impact of boundary effects such as ‘artificial’ backwater influence from outflow (downstream) boundaries and jetting of flows at inflow (upstream) boundaries
- ▶ There are several approaches to applying model boundaries to inland model domains that are dependent on the particular model application.

# BOUNDARIES

- ▶ In some instances, complex model bathymetries near the edge of a model domain make it difficult for the modeler to make a prior decision about how flow might leave the model domain in a controlled manner. In these instances you may decide simplify the flow exit issue by adding a wall all away around the model domain in order to avoid defining complex downstream boundaries.
- ▶ If, following initial model trial simulations it becomes evident that a large accumulation of flow is occurring at the closed boundaries (identifiable by 'puddling' or ponding of flow at the edges of the model) you may need to apply a model 'sink' at these locations to allow the flow to leave the model domain.

# BOUNDARIES

- ▶ In many riverine floodplain applications a hydrograph will be the inflow boundary to the 2D model.
- ▶ There are basically two ways of applying an inflow hydrograph. You can either specifying the hydrograph as an open boundary condition or as a source point.



# IMPLEMENTING A 2D MODEL IN HECRAS

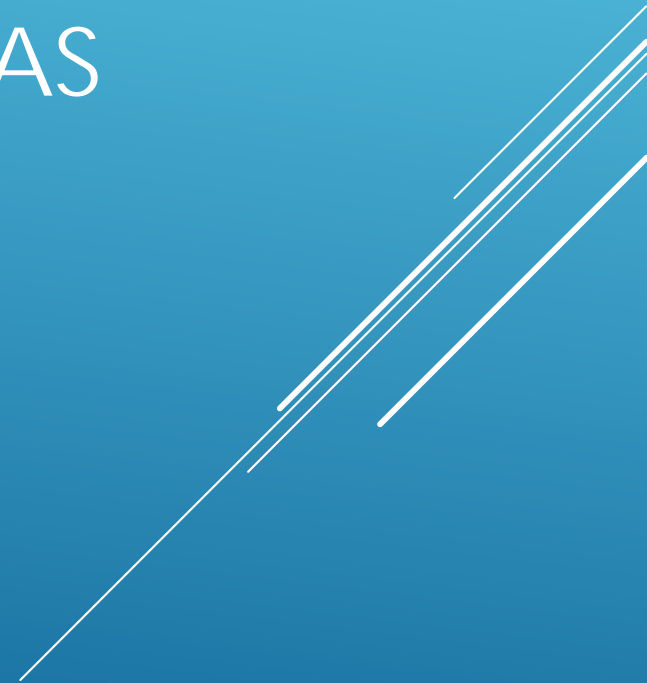

# RAS-MAPPER

- ▶ Every 2D model implementation should start with RAS-MAPPER

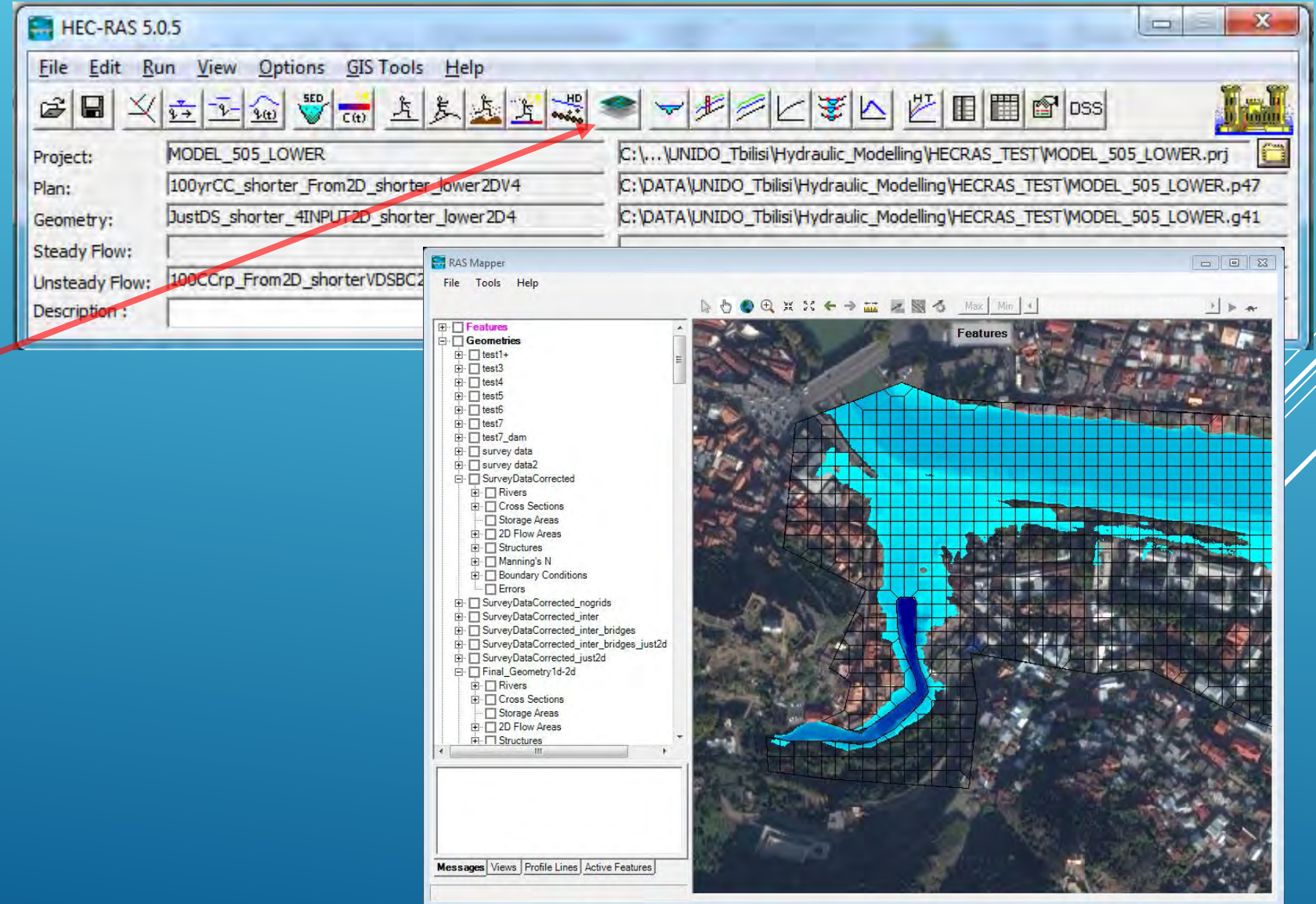

# PROJECTION

- ▶ The first step within RAS-MAPPER should be the selection of the projection.

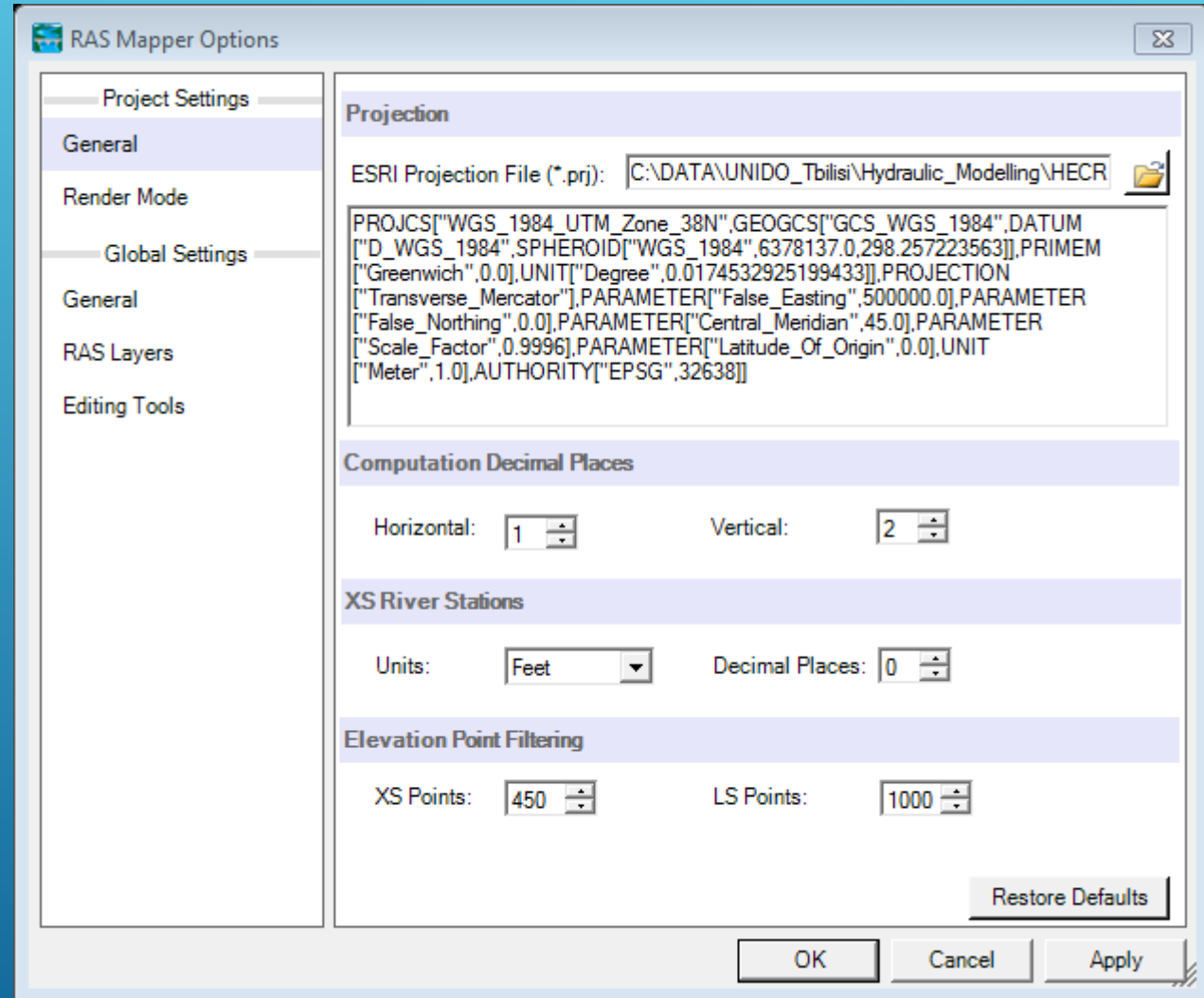

# TERRAIN

- ▶ The terrain for the modelling should be created.
- ▶ HECRAS accepts a wide range of data formats for the terrain
- ▶ This is created in the ‘New Terrain Layer’ option
- ▶ Several terrains can be created within a model
- ▶ Every geometry file should have an associated terrain file

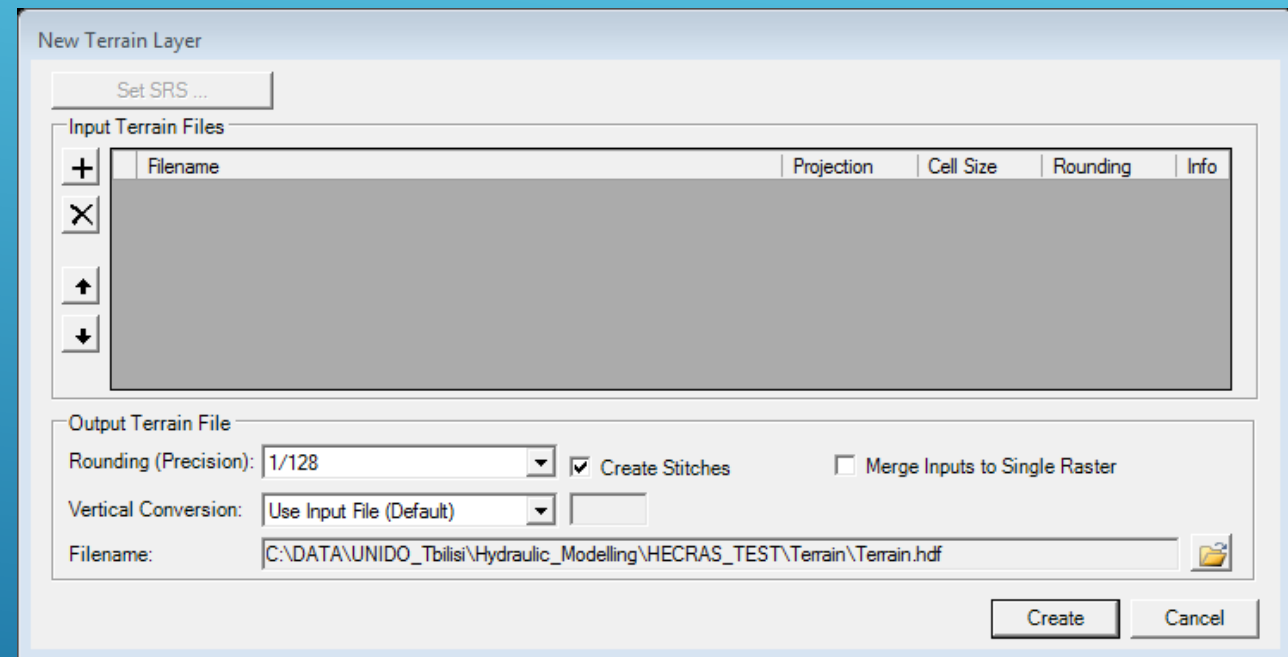

# GIS LAYERS

- ▶ Also, GIS layers (in shape format) can be added in the RAS-MAPPER
- ▶ This is a good idea to facilitate the modelling implementation
- ▶ In order to add file, use the ‘add existing GIS layer’ option
- ▶ Web imagery can be added too.

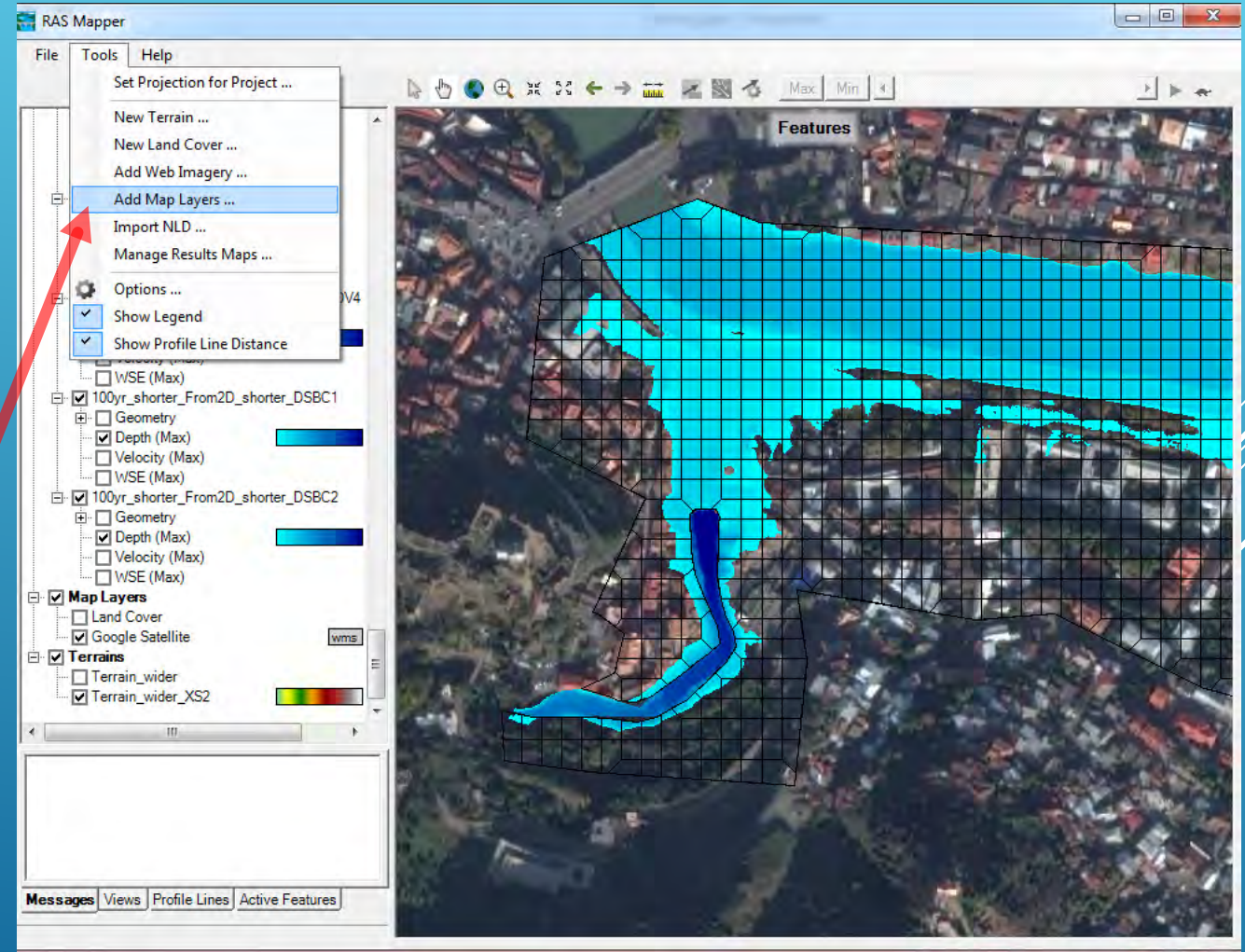

# GEOMETRY

- ▶ 2D Flow areas should be added in the Geometry Editor
- ▶ Click on the ‘2D Flow Area’ tool in the Geometry window
- ▶ Draw the 2D area in the required location
- ▶ Double click to finish drawing and provide a name

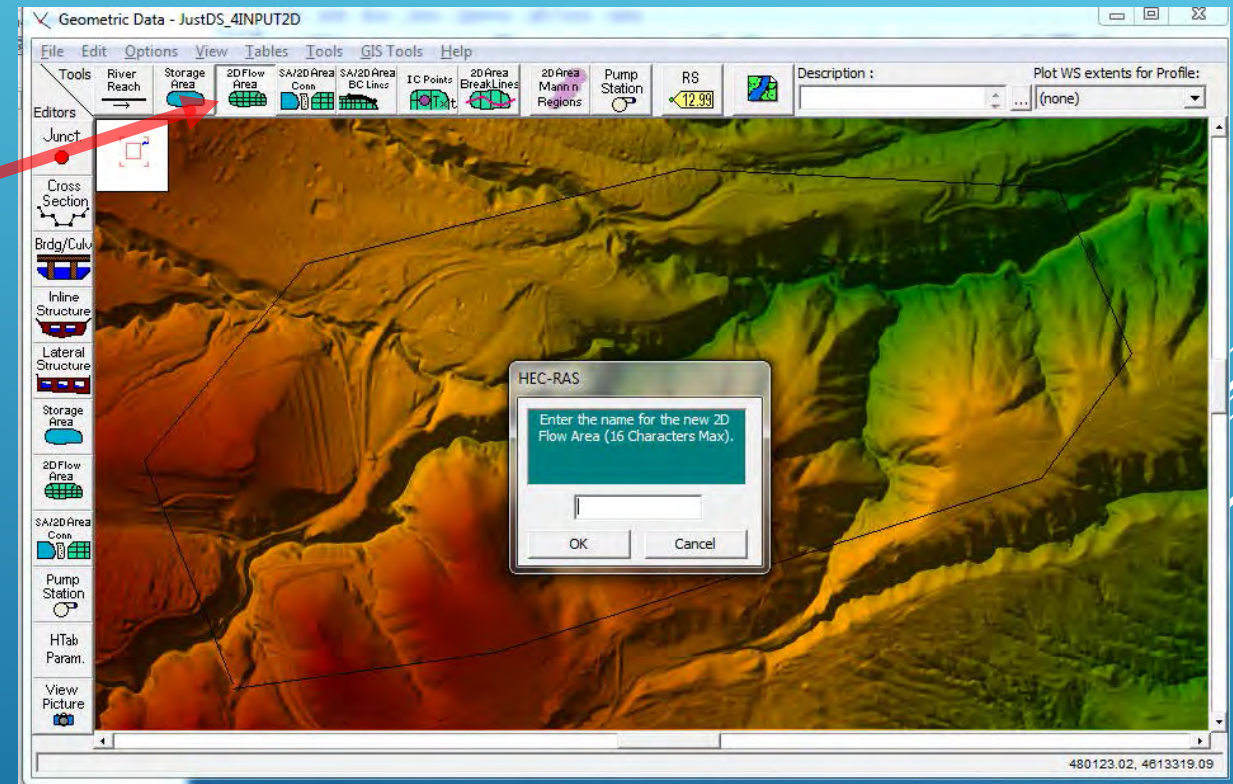

# GEOMETRY

- ▶ Details of the 2D grid are provided in the '2D Flow Area' Editor.
- ▶ Once clicked, the following window appears

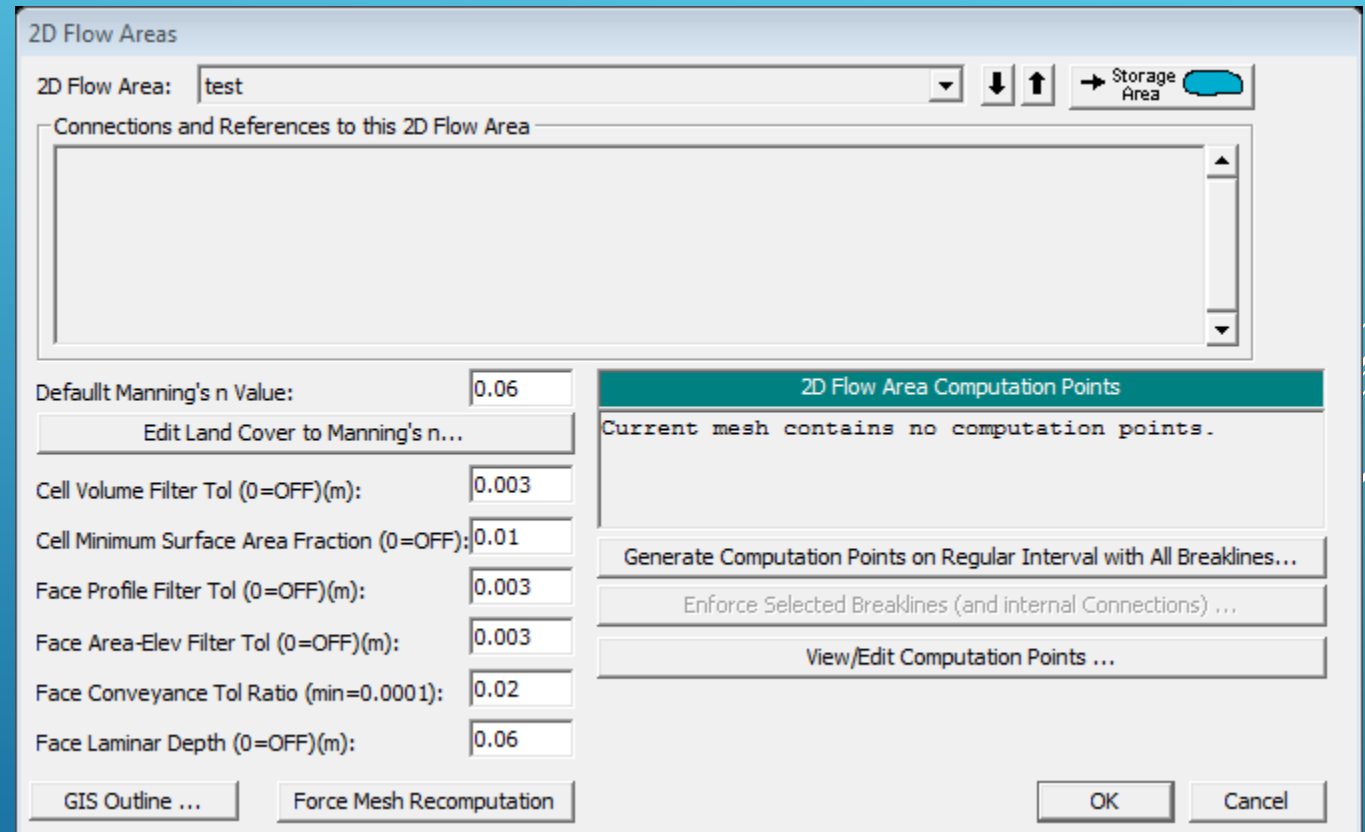

# GEOMETRY

- ▶ The most important value to provide at this stage is the grid resolution.
- ▶ Click in the ‘Generate Computation Points (...)’

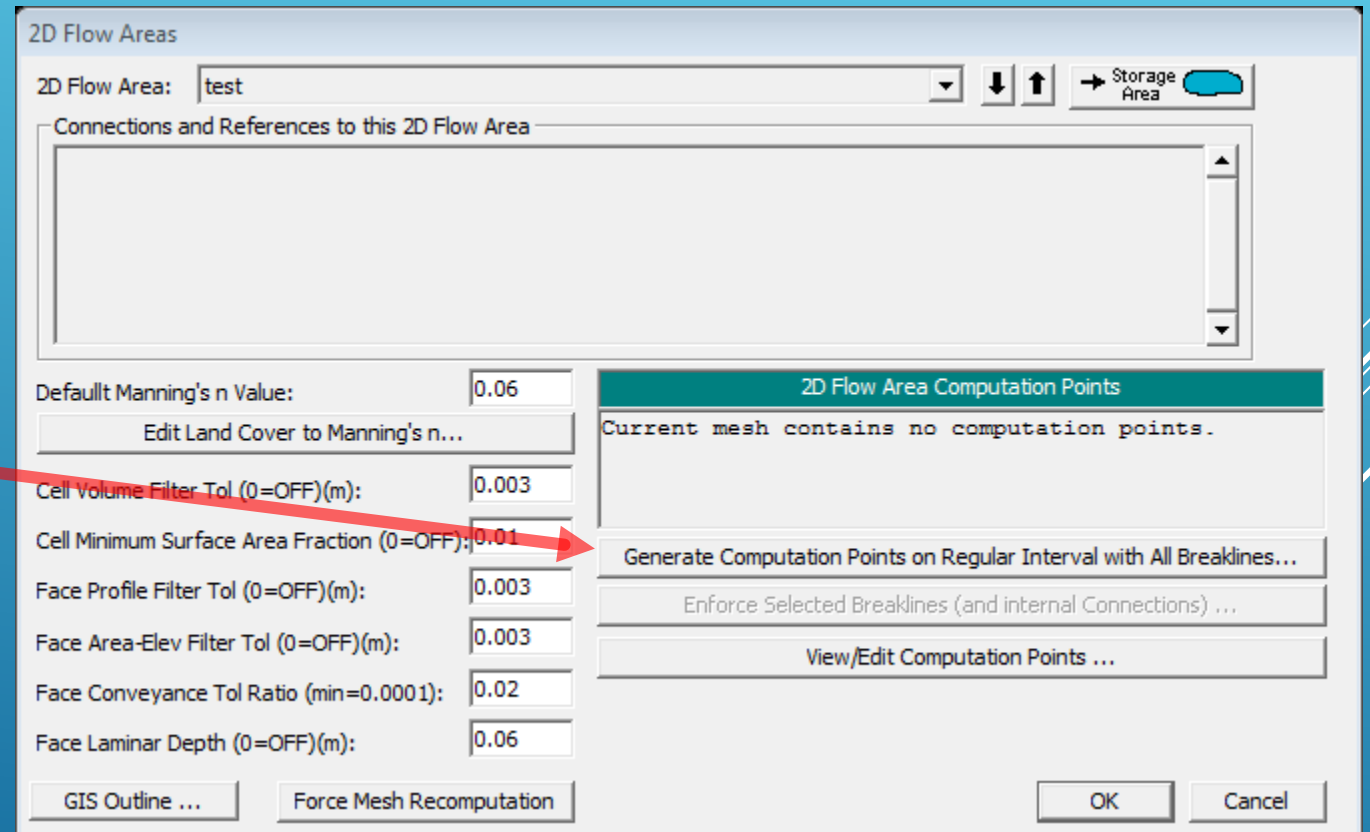
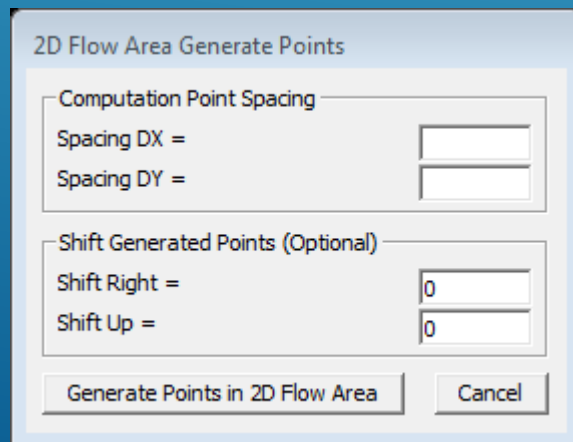

# GEOMETRY

- ▶ Information about the spacing in the 'x' and 'y' direction has to be provided
- ▶ After clicking 'generate points in 2D Flow area', the grid will be created

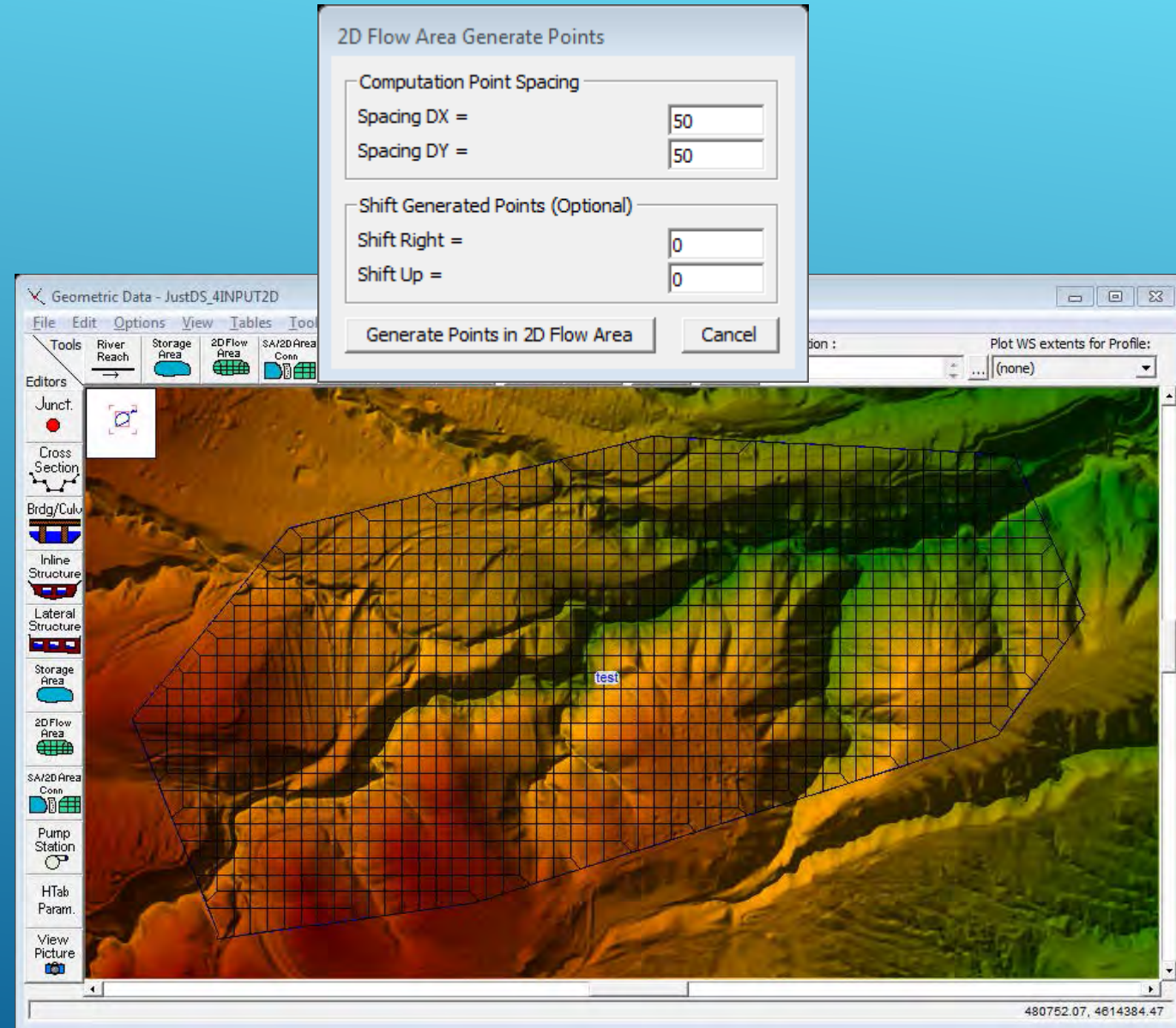

# GEOMETRY

- ▶ The grid resolution is a very important value
- ▶ It will determine the resolution of the results
- ▶ It will also determine the time-step to be used
- ▶ An inadequate time-step will produce unstable results
- ▶ A sensitivity test should be undertaken in order to find the correct time-step for each grid resolution.

# BOUNDARIES

- ▶ Boundaries have to be defined first in the geometry editor.
- ▶ Click in the 'SA/2D Area BC Lines Tool'.

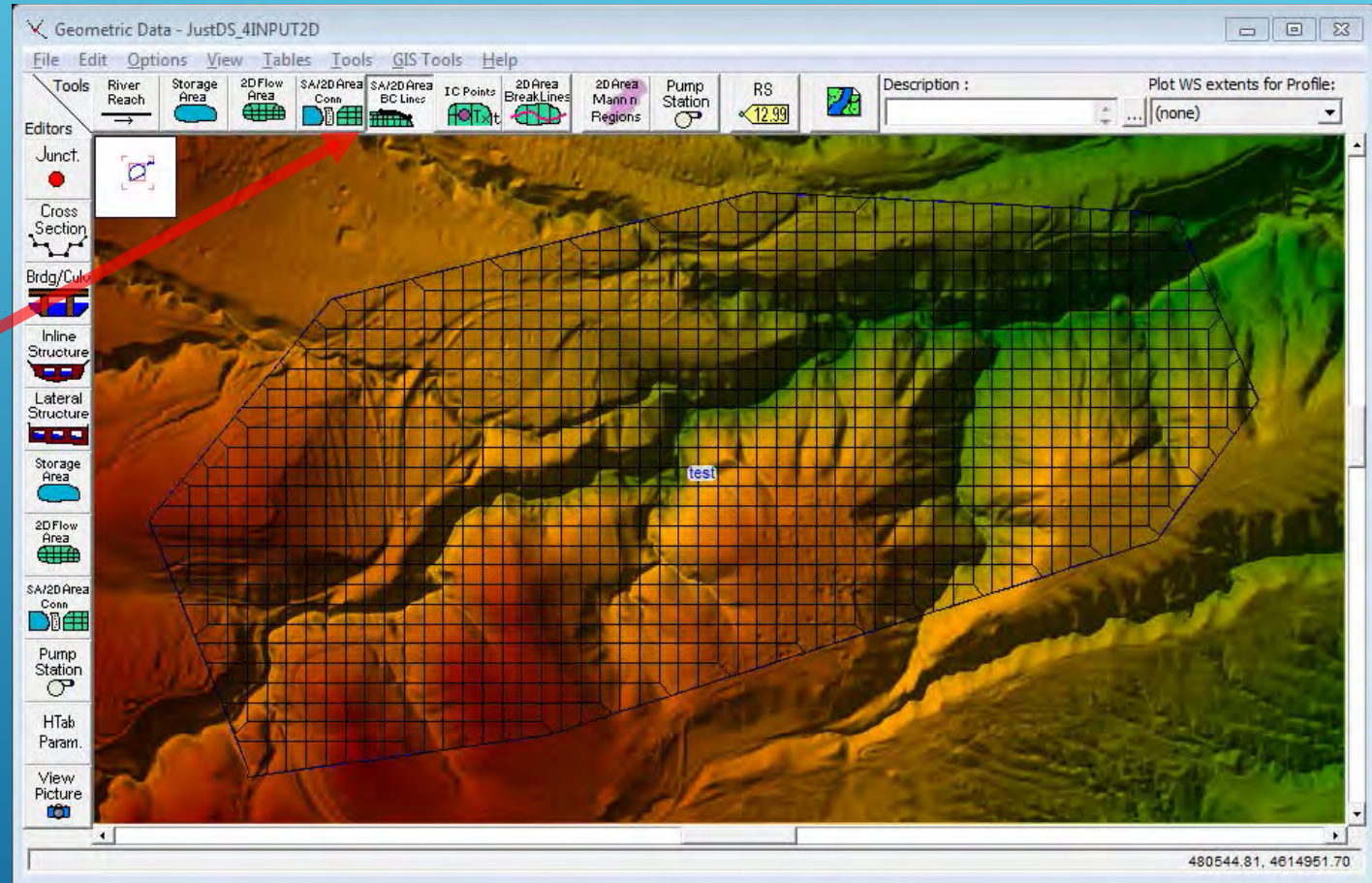

# BOUNDARIES

- ▶ Boundaries can be drawn either outside or inside the 2D flow area domain
- ▶ The same boundary cannot be inside and outside at the same time.
- ▶ A different name has to be applied to each boundary
- ▶ The 2D model can run without boundaries
- ▶ Nonetheless it is recommended that both US and DS boundaries exist, unless the model is connected to a 1D model with its own boundaries

# BOUNDARIES

- ▶ The pre-defined boundaries have to be further detailed in the 'unsteady flow' editor.
- ▶ 2D modelling can just be unsteady
- ▶ The process to define this is equivalent to the one for 1D modelling
- ▶ The only exception is that 'precipitation' boundaries are available in 2D

The screenshot displays two windows from a software application. The left window is titled 'Boundary Conditions' and shows a configuration panel for 'Boundary Condition Types'. It includes buttons for 'Stage Hydrograph', 'Flow Hydrograph', 'Stage/Flow Hydr...', 'Rating Curve', 'Normal Depth', 'Lateral Inflow Hydr...', 'Uniform Lateral Inflow', 'Groundwater Interflow', 'T.S. Gate Openings', 'Elev. Controlled Gates', 'Navigation Dams', and 'IB Stage/Flow...'. A 'Precipitation' button is highlighted. Below this is a table for 'Select Location in table then select Boundary Condition Type'.

River	Reach	RS	Boundary Condition
1 Legvtakhevi	1	1783.215	
2 Legvtakhevi	1	466.2211	Flow Hydrograph
3 Legvtakhevi	1	0	Stage Hydrograph

Below the table is a section for 'Storage/2D Flow Areas' with a table:

Storage/2D Flow Areas	Boundary Condition
1 lower	Normal Depth
2 test	Precipitation

The right window is titled 'SA: test' and shows a 'Hydrograph Data' table. It includes a 'Simulation Time' column in hours and a 'Precipitation' column in mm. The simulation time ranges from 00:00 to 19:00 in 1-hour increments. The precipitation column is currently empty.

Simulation Time (hours)	Precipitation (mm)
00:00	
01:00	
02:00	
03:00	
04:00	
05:00	
06:00	
07:00	
08:00	
09:00	
10:00	
11:00	
12:00	
13:00	
14:00	
15:00	
16:00	
17:00	
18:00	
19:00	

# EXECUTE THE 2D MODEL

- ▶ 2D models are executed in the same way as 1D unsteady models
- ▶ RAS-MAPPER can be used to examine the results

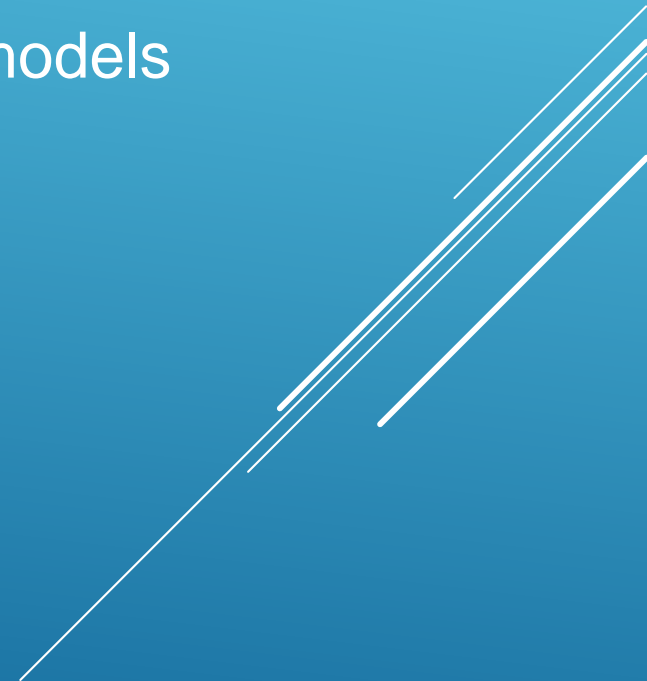

# DELFT-FEWS

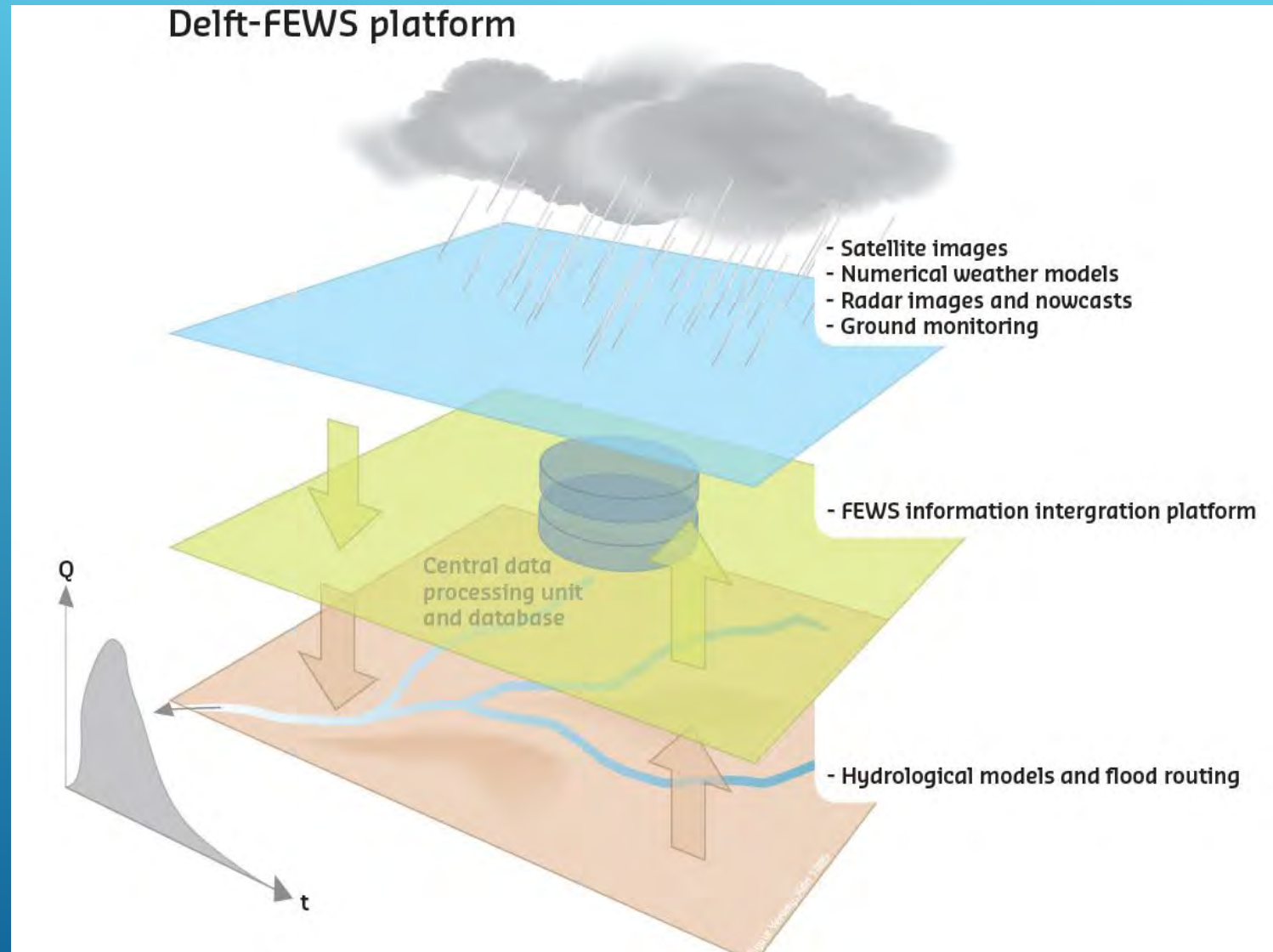

# DELFT-FEWS

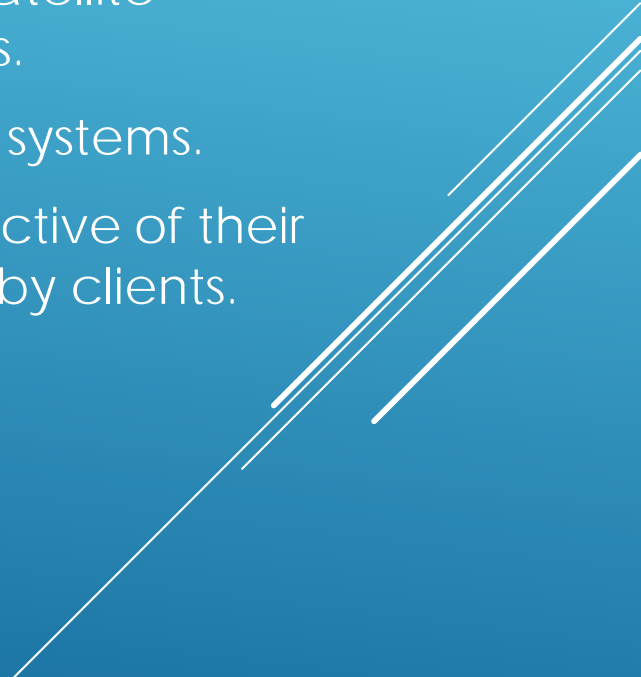
- ▶ Create a generic information platform for data processing to serve the installation of flood and environmental forecasting systems .
  - ▶ Create links to all kinds of meteorological data sources, such as ground station monitoring devices, weather radar, numerical weather models and satellite images and provide facilities to process such data in required formats.
  - ▶ Create links to a wide range of hydrological and hydraulic modelling systems.
  - ▶ Make it easy to connect all kinds of models and data sources, irrespective of their producers in order to avoid capital destruction of earlier investments by clients.
  - ▶ Make the system resilient
- 

# DELFT-FEWS

- ▶ Toolbox for development of forecasting systems
- ▶ Binding dataflows + models
- ▶ Fully 'configurable' by user
- ▶ Real-Time
- ▶ Rapid implementation, scalable & flexible
- ▶ High resilient & automatic /manual & stand alone

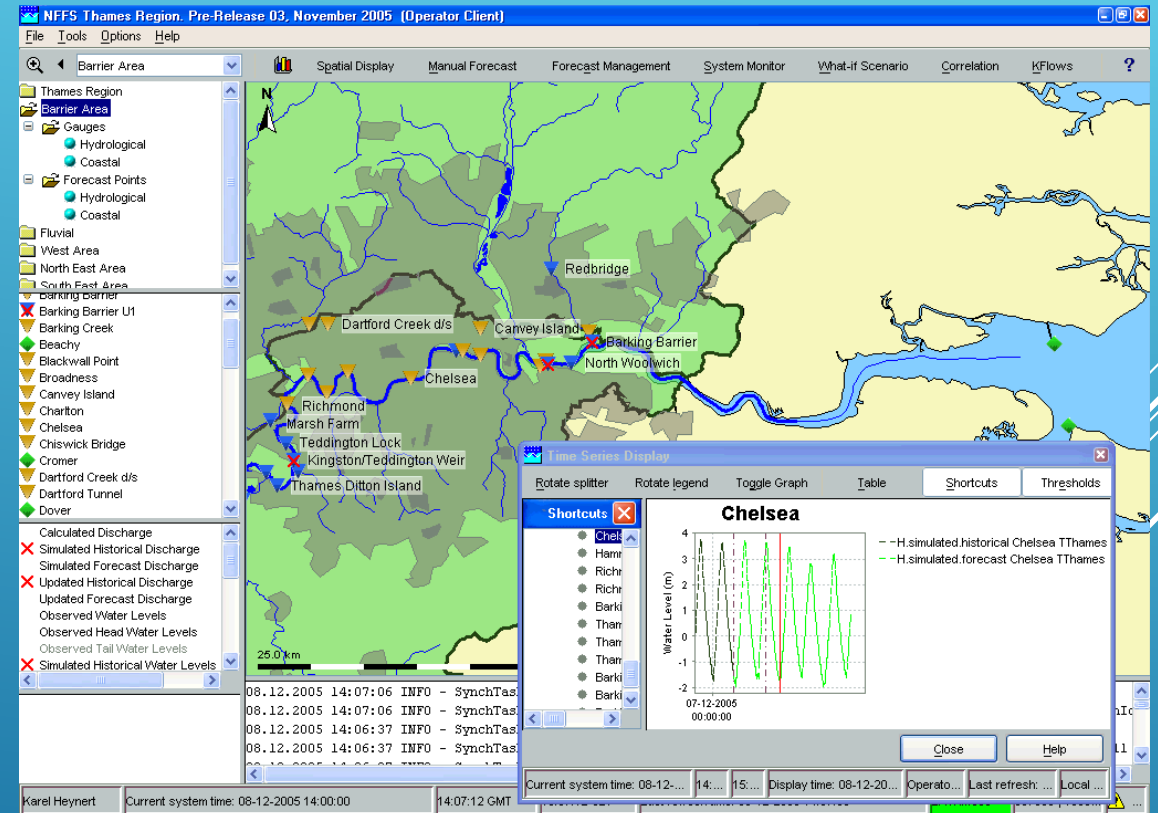

# DELFT-FEWS

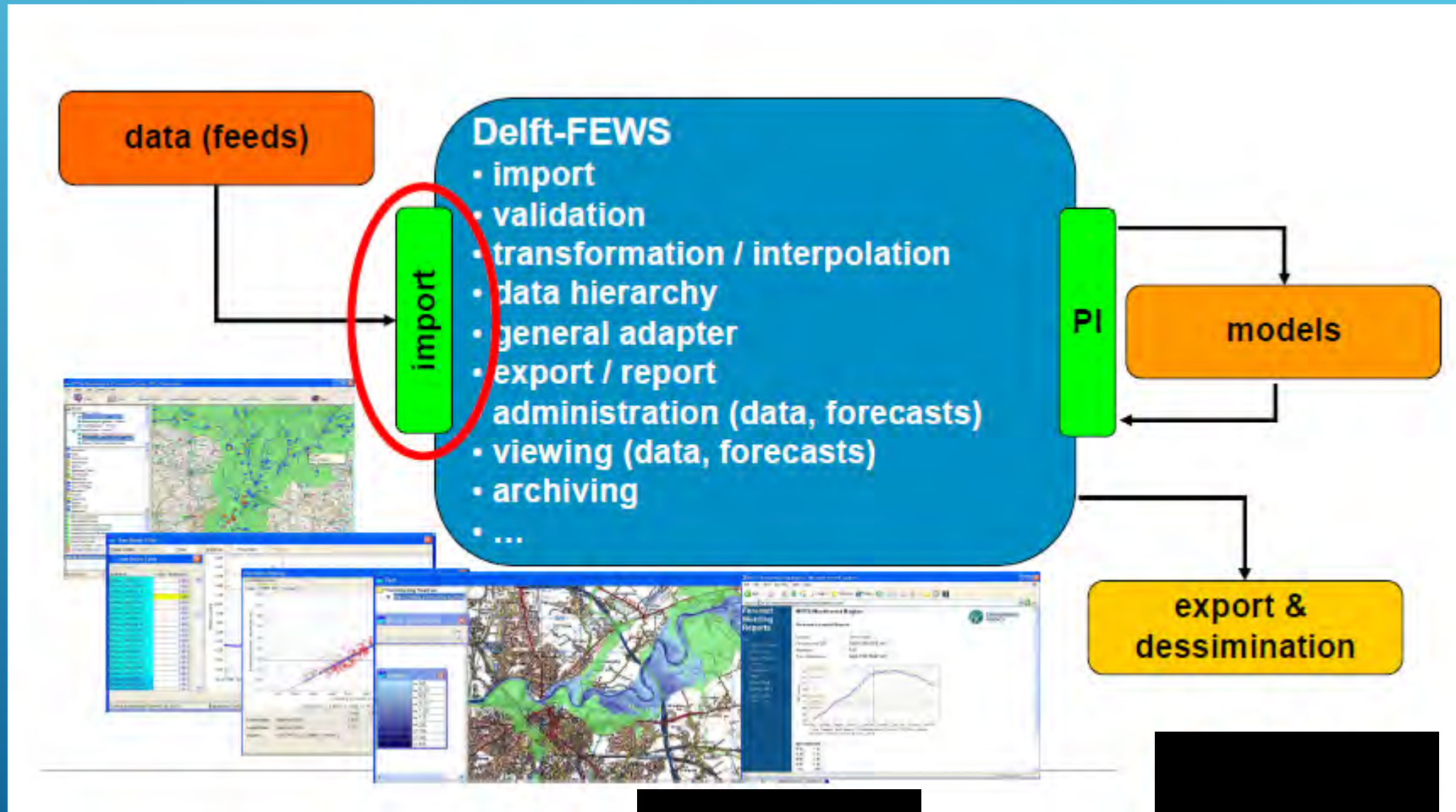

# DELFT-FEWS

- ▶ Data import formats available

## **Scalar (examples)**

CSV  
DINO  
DiverMon  
HDF4  
Hydris  
HYMOS  
KNMI  
Mosaic  
NOOS  
PI  
SSE  
SHEF  
TMX  
WISKI  
...and many more

## **Grid formats (examples)**

ArcInfoAscii  
BIL  
BUFR  
COSMO7\_COR  
Several DWD formats  
GRIB  
GRIB2  
KNMI-HDF5  
Landsat-HDF5  
MATROOS NetCDF  
NetCDF  
Nimrod  
SwissRadar  
GrayscaleImage  
... and many more

# DELFT-FEWS

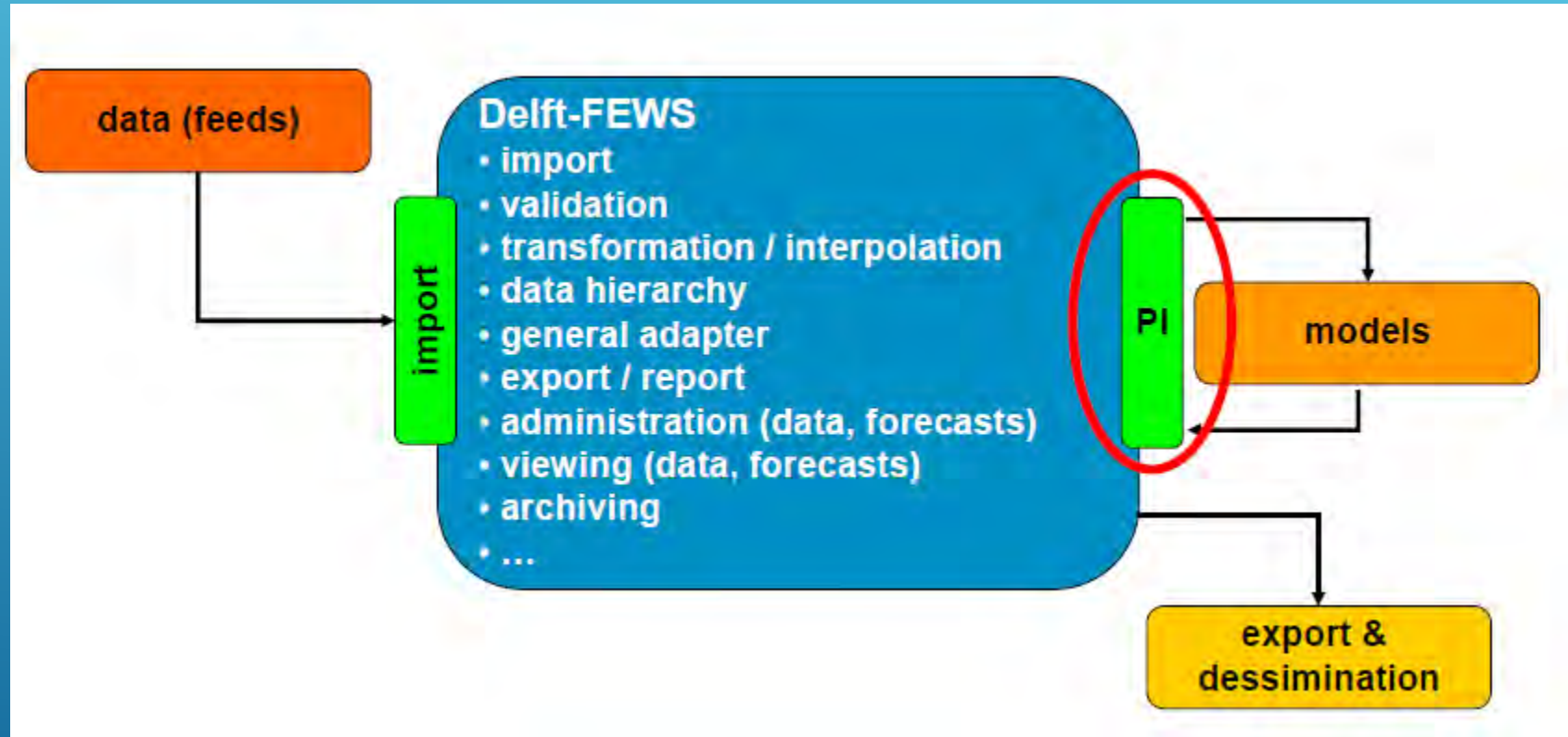

# DELFT-FEWS

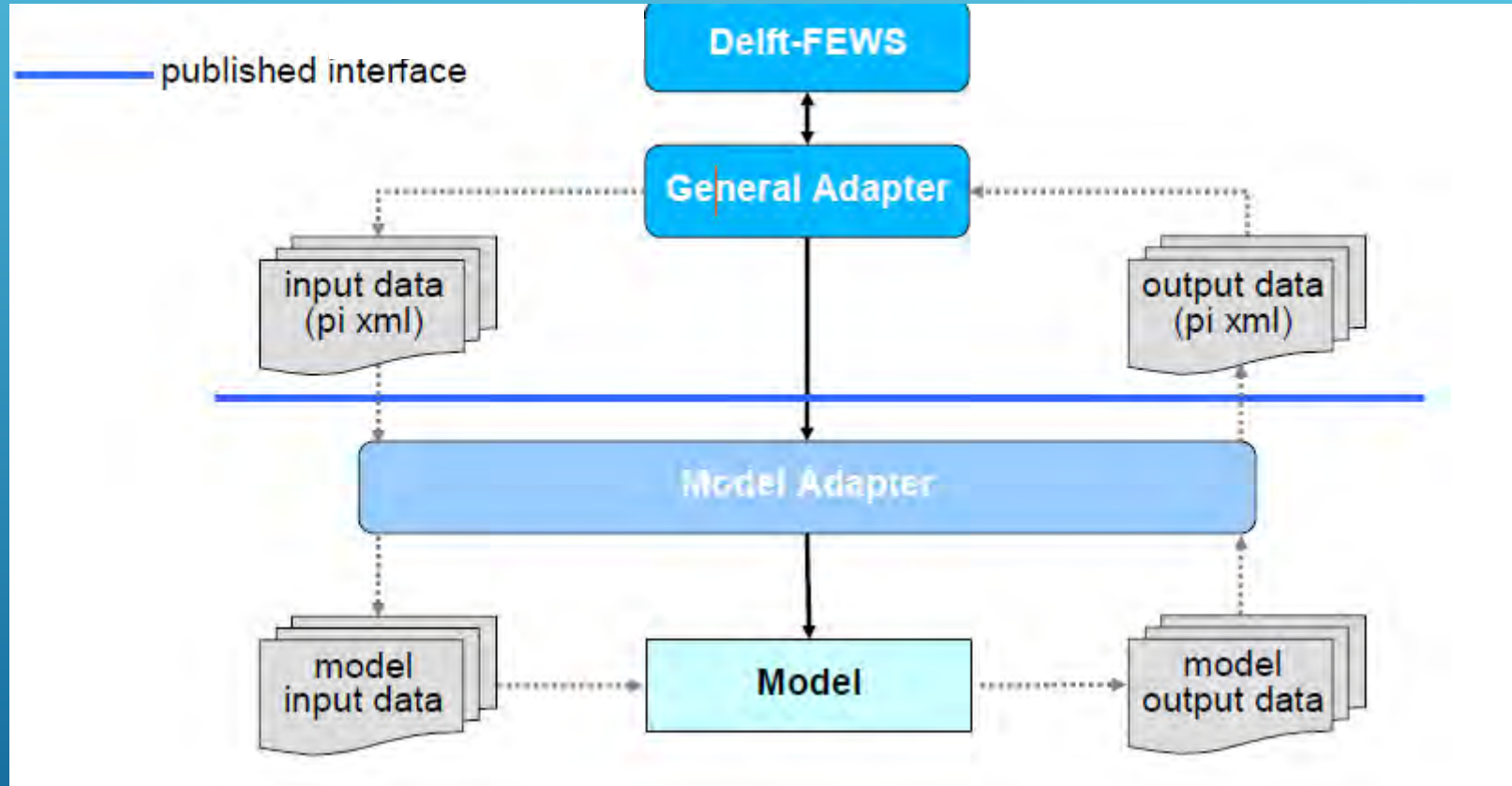

# DELFT-FEWS EXTERNAL MODEL ADAPTERS

- HR (ISIS)
- PlanB Adapters (TRITON & PRTF)
- DHI Adapters (Mike11, NAM)
- Midlands Region (DODO, MCRM)
- Southern Region (STF)
- Northwest Region (NW TF – Common Adapter)
- Wales (SW Overtopping module - Common Adapter)
- SouthWest (Bruton/Holbeam Dam module – Common Adapter)
- Deltares (RTC Tools, Delft3D, SOBEK, RIBASIM, HYMOS, Sacramento, SSARR)
- SMHI (HBV)
- University of Karlsruhe (PRMS)
- JRC (Lisflood - PCRaster)
- NWS (SNOW17, SAC-SMA, UNIT-HG, LAG/K, SARRROUTE, SSARRESV, RESSNGL, BASEFLOW, CHANLOSS, APICONT, CONSUSE, GLACIER, LAYCOEF, MUSKROUT, RSNELEV, SAC-SMA-HT, TATUM)
- USACE (HEC-RAS, HEC-ResSim)

# DELFT-FEWS

## Software...

- Service Oriented Architecture
  - operating (business) aspects
  - system / platform 'independent'
- Java, XML & JMS
- Oracle, PostgreSQL, MS SQLServer

## Open Systems Approach...

- Can be extended using plug-ins (Modules, Displays)
- Transparent configuration using XML file format
- External modules can be integrated using XML as exchange format
- Provides access to time-dependent data via JDBC, WebServices

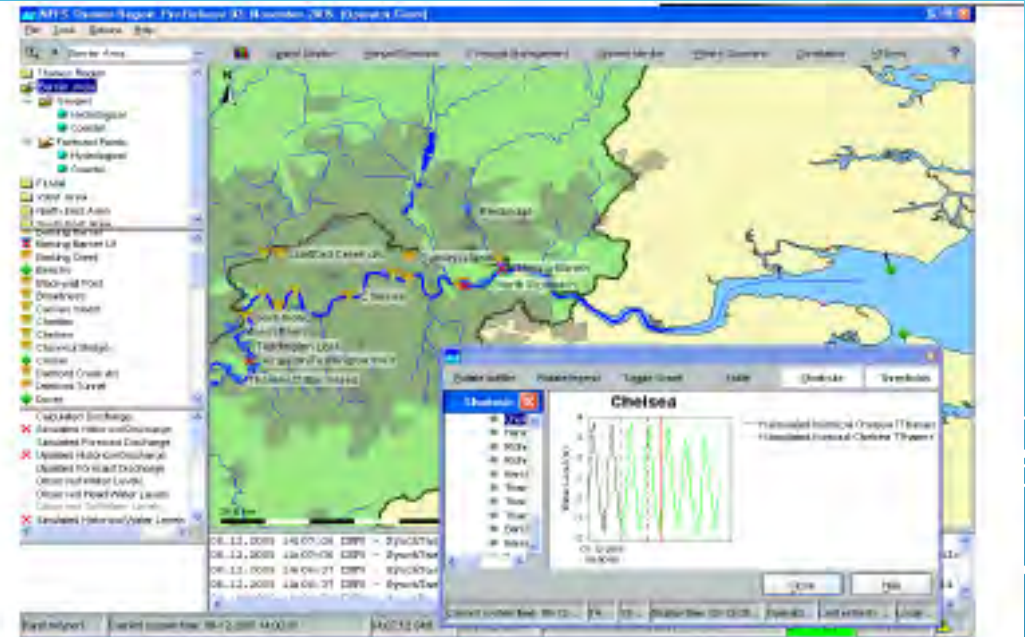

# DELFT-FEWS EXPLORER

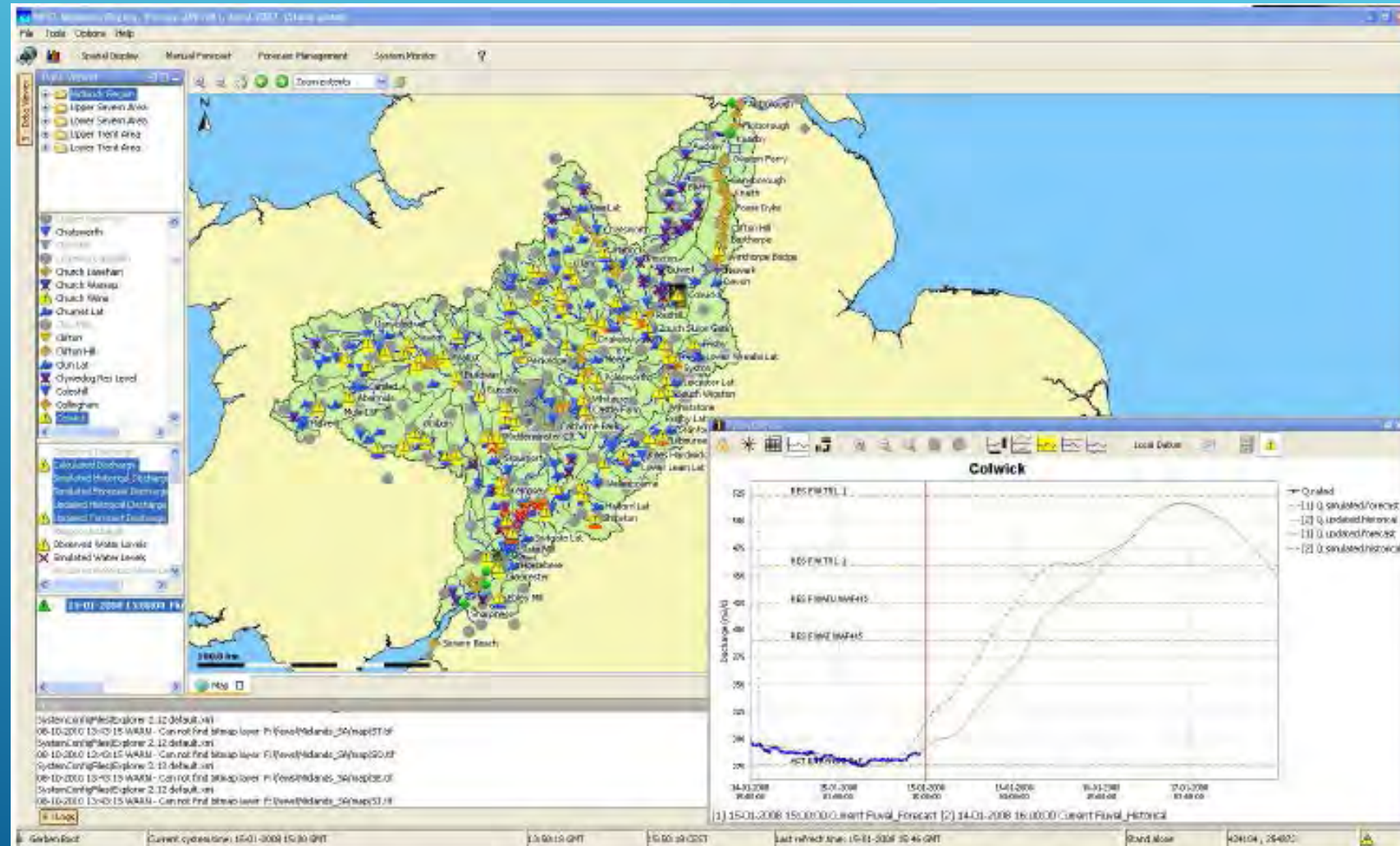

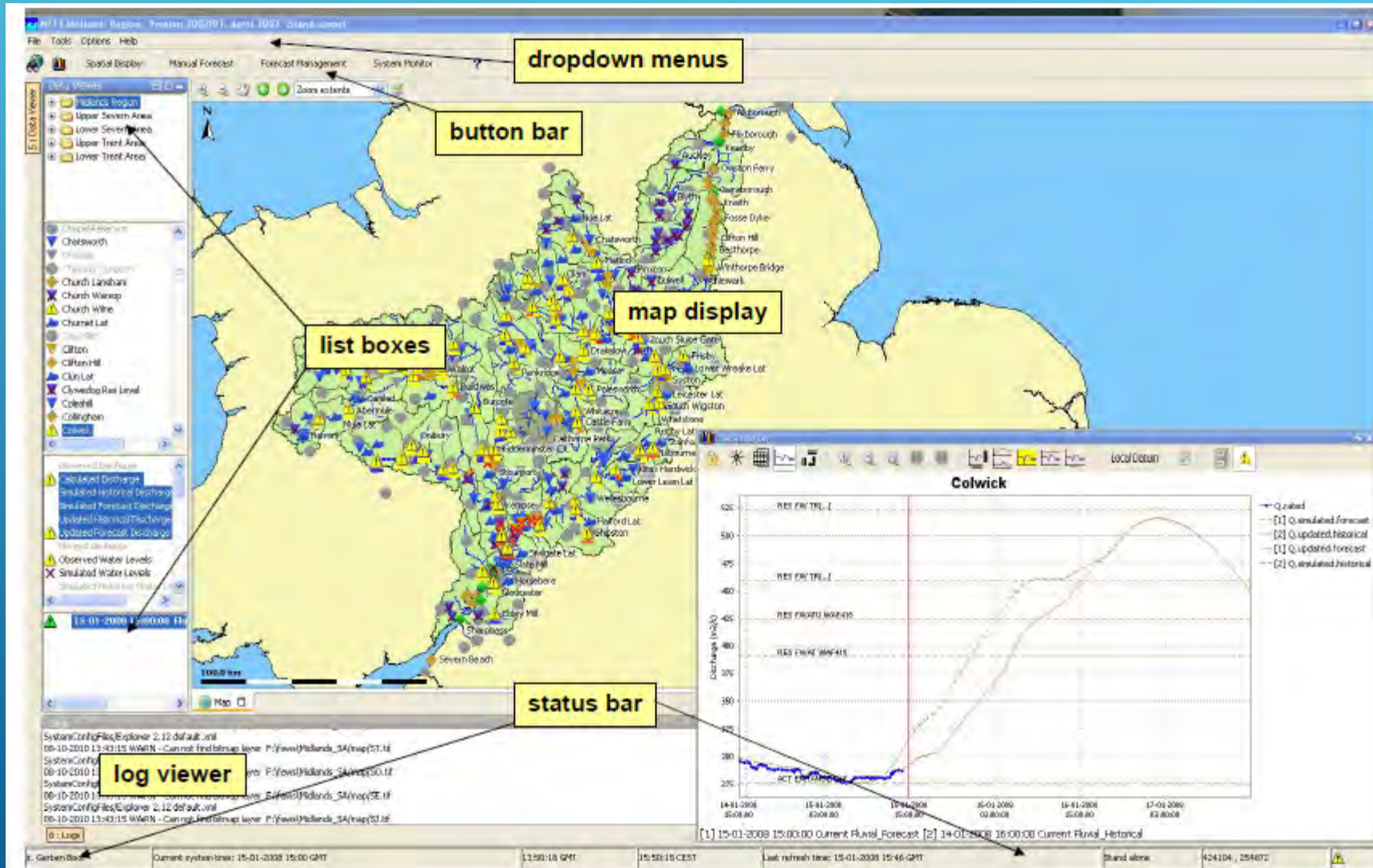

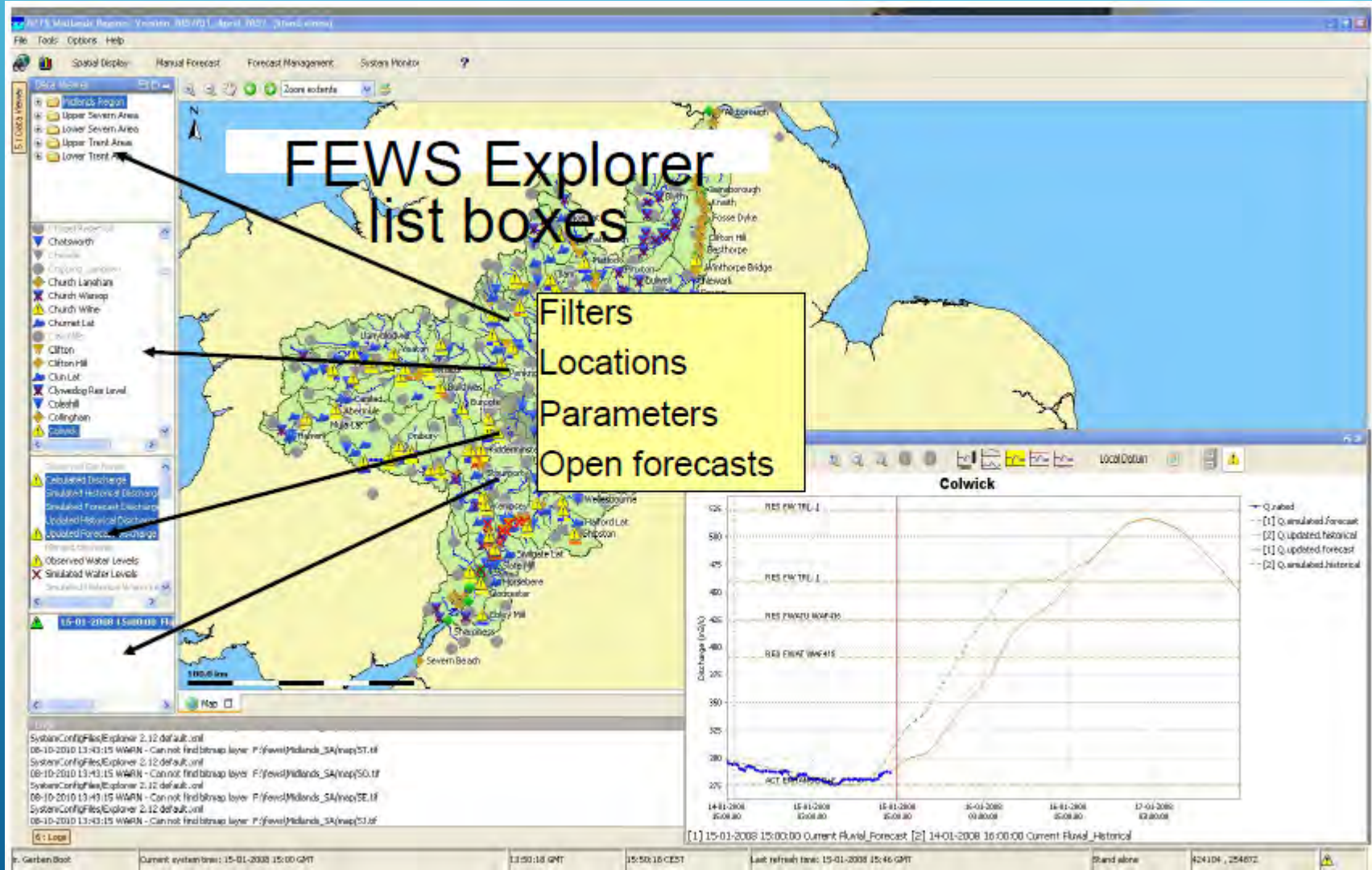

# DELFT-FEWS SETTINGS

- ▶ Stand alone
  - ▶ All activities are done on (your) local machine (desktop/laptop)
- ▶ Client-Server
  - ▶ Clients log on to 'central backend'
    - ▶ calculations are done on designated machines/servers
    - ▶ data 'downloaded' to local machine (laptop/desktop)
    - ▶ activities scheduled with fixed intervals (import, forecasts)
    - ▶ manually invoked activities from clients queue

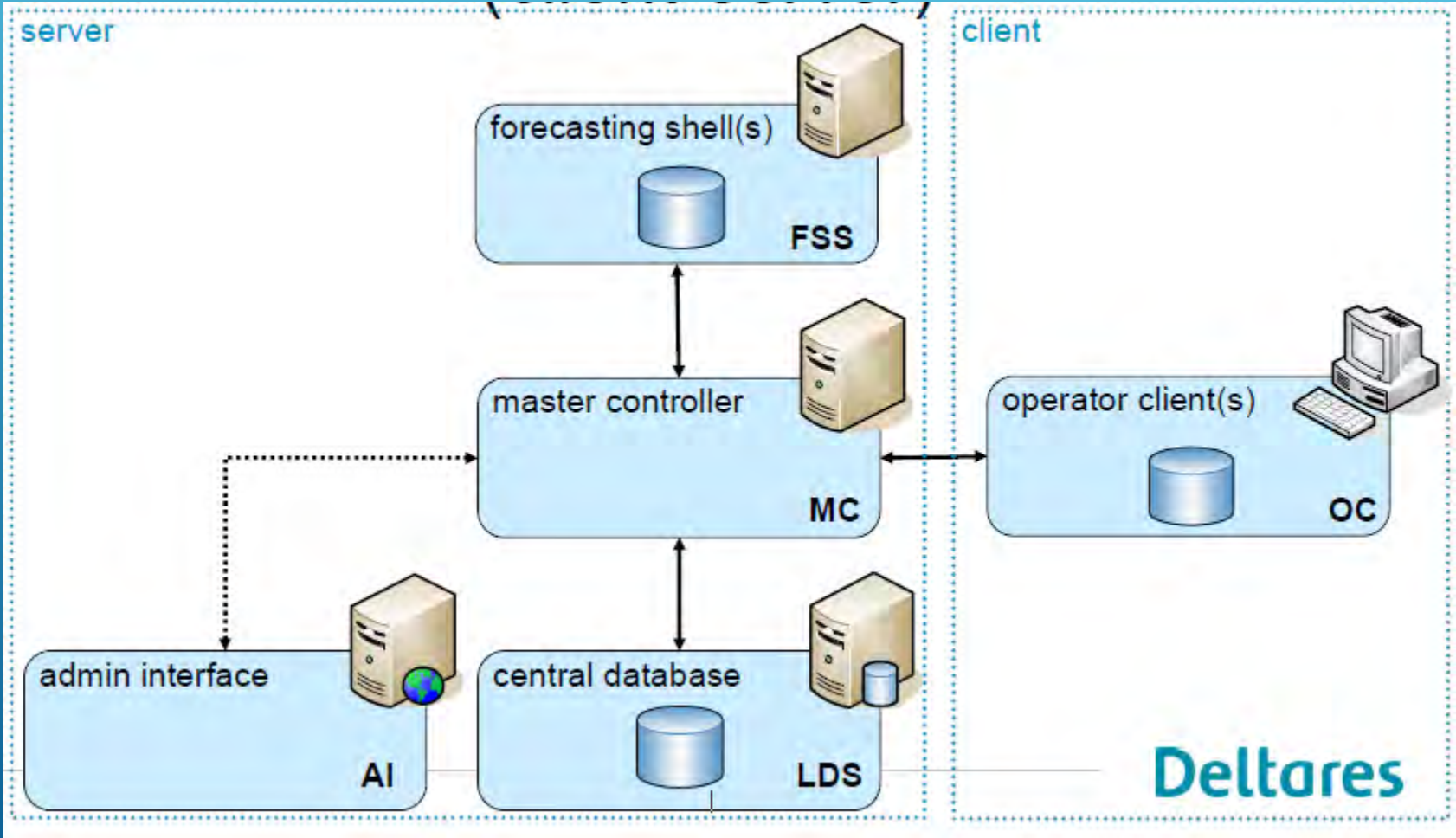

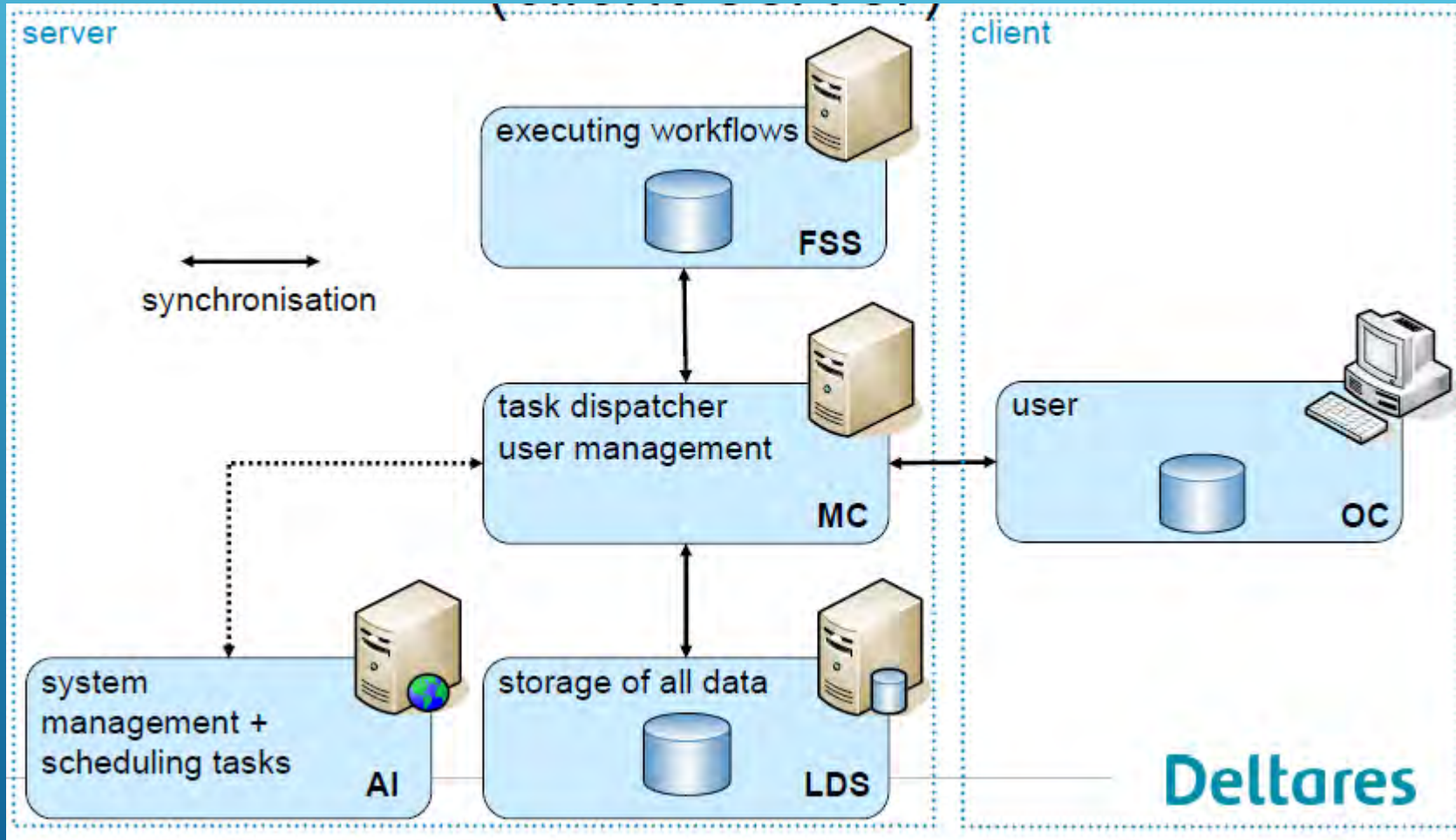

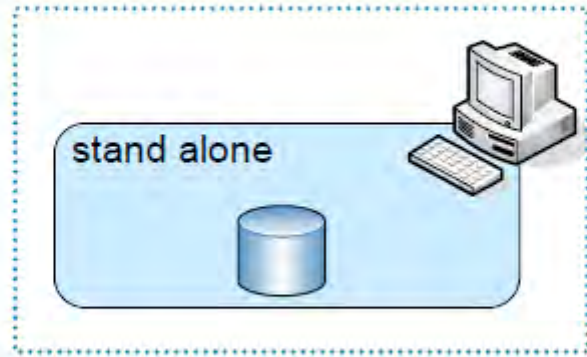

# FEWS CONFIGURATION

Elements of the DELFT-FEWS configuration

- ▶ Main DELFT-FEWS configuration (*config* directory)
- ▶ External Modules
- ▶ ColdStates

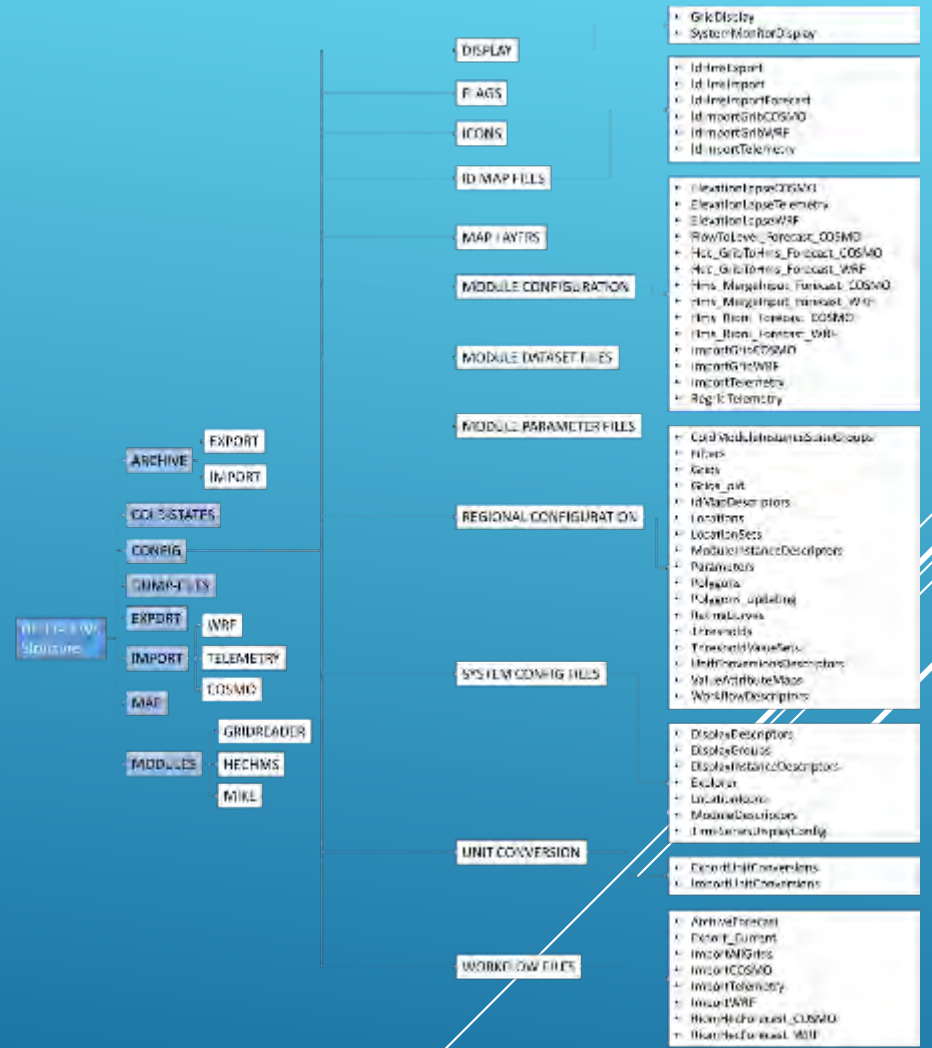

# FEWS CONFIGURATION

## Archive

- ▶ The archive folder contain two different folder about import and export datasets.

## Cold States

- ▶ This folder contains information about the different cold-states files used for the simulations or the linked models.

## Config

- ▶ The 'config' folder is the main folder within DELFT-FEWS containing all the different configuration information. Display, module configuration, regional configuration, system configuration, workflows and unit conversion XML files are contained within this folder. These are some of the important files within this folder.

# CONFIG FOLDER

- ▶ Definition of regional configuration, including all locations, parameters etc. - RegionConfigFiles
- ▶ Definition of system configuration items, including the plug-ins available to the system, definition, icons etc. - SystemConfigFiles
- ▶ Definition of modules for handling data and running forecasting models - ModuleConfigFiles
- ▶ Definition of workflows for running sequences of modules - WorkflowFiles
- ▶ Cold states for modules. Zip file containing model specific data exported by GA usually before running a model - ColdStateFiles
- ▶ Definition of mapping of ID's and parameters between external sources (e.g. telemetry, modules) and ID's and parameters defined in the DELFT-FEWS configuration - IdMapFiles

# CONFIG FOLDER

- ▶ Definition of unit conversions between external sources (e.g. telemetry, modules) and units used in DELFT-FEWS - UnitConversionFiles
- ▶ Definition of flag conversions between external sources (e.g. telemetry, modules) and flags used in DELFT-FEWS - FlagConversionFiles
- ▶ Definition of layout of user displays, including What-if scenarios, Grid Display etc.) - DisplayConfigFiles
- ▶ Definition of module parameters stored in DELFT-FEWS - ModuleParameters
- ▶ Zipped files containing datasets for modules used by the forecasting system - ModuleDataSetFiles
- ▶ Definition of HTML template files used in creating HTML reports for use on the web server. - ReportTemplateFiles
- ▶ Map layers (shape files) used in main map display and spatial interpolation - MapLayerFiles
- ▶ Images used in reports etc - ReportImageFiles
- ▶ Icons used in main map display and button bar - IconFiles

# FEWS CONFIGURATION

## ▶ **Dump-files**

- ▶ In this directory the dump files are written to. These Dump Files are created when one of the execute activities fails. A dump file is a ZIP file which includes all the dumpDir directories defined. The dump file is created immediately on failure, meaning that all data and files are available as they are at the time of failure and can be used for analysis purposes. The ZIP file name is time stamped to indicate when it was created.

## ▶ **Export**

- ▶ In the Export directory all the different export files are located temporarily.

## ▶ **Import**

- ▶ Within this folder there are directories for all the different data to be imported into DELFT-FEWS. There are folders for the two meteorological models (WRF and COSMO), for the telemetry data and for the satellite precipitation data (TRMM/GPM and MPE). In this folder to files to be imported are periodically placed. It should be noted that a back-up of this files should be kept somewhere prior the import process, because once they are imported to the platform, those files are deleted by the importing process. If the import process fails for some files, those files will be moved to the ImportFailed directory. Otherwise they will be deleted unless it is specified otherwise.

# FEWS CONFIGURATION

- ▶ **Map**

- ▶ Within this folder the different GIS files used in the visualisation platform can be found.

- ▶ **Modules**

- ▶ All the different models connected within DELFT-FEWS have a folder within this directory. In this case a folder for HEC-HMS, MIKE and the GridReader exist. Within the respective folders information about the link procedure, operational files (\*.bat) and the actual models are located.